



---

## CITY COUNCIL REGULAR MEETING AGENDA

MAYOR CORY MOSS  
MAYOR PRO TEM MICHAEL GREUBEL  
COUNCIL MEMBER STEVE MARCUCCI  
COUNCIL MEMBER MARK D. RADECKI  
COUNCIL MEMBER NEWELL RUGGLES

**APRIL 24, 2025 AT 9:00 AM**

---

**LOCATION:** City Council Chambers, 15651 Mayor Dave Way, City of Industry, California

---

### **ADDRESSING THE CITY COUNCIL:**

**Agenda Items:** Members of the public may address the City Council on any matter listed on the Agenda. In order to conduct a timely meeting, there will be a one-minute time limit per person for any matter listed on the Agenda. Anyone wishing to speak to the City Council is asked to complete a Speaker's Card which can be found at the back of the room and at the podium. The completed card should be submitted to the City Clerk prior to the Agenda item being called and prior to the individual being heard by the City Council.

**Public Comments (Non-Agenda Items):** Anyone wishing to address the City Council on an item not on the Agenda may do so during the "Public Comments" period. In order to conduct a timely meeting, there will be a one-minute time limit per person for the Public Comments portion of the Agenda. State law prohibits the City Council from taking action on a specific item unless it appears on the posted Agenda. Anyone wishing to speak to the City Council is asked to complete a Speaker's Card which can be found at the back of the room and at the podium. The completed card should be submitted to the City Clerk prior to the Agenda item being called by the City Clerk and prior to the individual being heard by the City Council.

At the time of publication, no Councilmembers intend to take part in the meeting remotely under the provisions of AB 2449. Should that change between the time of publication and the start of the meeting, a live webcasting of the meeting will be accessible via the link, meeting ID, and meeting passcode listed below. Whenever possible, an announcement will be made at the start of the meeting via the live webcast to confirm whether or not a Councilmember will join remotely. If they will not be joining remotely, then the live webcast will terminate after the announcement.

[www.microsoft.com/microsoft-teams/join-a-meeting](http://www.microsoft.com/microsoft-teams/join-a-meeting)

Meeting ID: 298 577 003 546 5

Meeting Passcode: mv3az9Tw

**Or call in (audio only)**

+1 657-204-3264,

Phone Conference ID: 684 844 642#

### **AMERICANS WITH DISABILITIES ACT:**

In compliance with the ADA, if you need special assistance to participate in any City meeting (including assisted listening devices), please contact the City Clerk's Office (626) 333-2211. Notification of at least 48 hours prior to the meeting will assist staff in assuring that reasonable arrangements can be made to provide accessibility to the meeting.

### **AGENDAS AND OTHER WRITINGS:**

In compliance with SB 343, staff reports and other public records permissible for disclosure related to open session agenda items are available at City Hall, 15625 Mayor Dave Way, City of Industry, California, at the office of the City Clerk during regular business hours, Monday through Thursday 8:00 a.m. to 5:00 p.m., Fridays 8:00 a.m. to 4:00 p.m. Any person with a question concerning any agenda item may call the City Clerk's Office at (626) 333-2211.

1. Call to Order
2. Flag Salute
3. AB 2449 Vote on Emergency Circumstances (if necessary)
4. Roll Call
5. Presentations-San Gabriel Valley Council of Government 57/60 Freeway Project Update.

**6. CONSENT CALENDAR**

- 6.1. Consideration of the Register of Demands for April 24, 2025

**RECOMMENDED ACTION:** Approve the Register of Demands and authorize the appropriate City Officials to pay the bills.

- 6.2. Consideration of Resolution No. CC 2025-12– A RESOLUTION OF THE CITY COUNCIL OF THE CITY OF INDUSTRY, CALIFORNIA, APPROVING A DONATION TO EAST SAN GABRIEL VALLEY COALITION FOR THE HOMELESS, IN THE AMOUNT OF TWENTY THOUSAND DOLLARS (\$20,000.00), FOR ITS HOMELESS PROGRAMS

**RECOMMENDED ACTION:** Approve Resolution CC 2025-12

- 6.3. Consideration of Resolution No. CC 2025-13 – A RESOLUTION OF THE CITY COUNCIL OF THE CITY OF INDUSTRY, CALIFORNIA, APPROVING A DONATION TO PACIFIC CREST YOUTH ARTS ORGANIZATION, IN THE AMOUNT OF TEN THOUSAND DOLLARS (\$10,000.00), FOR THE PACIFIC CREST OUTREACH PROGRAM

**RECOMMENDED ACTION:** Approve Resolution CC 2025-13

- 6.4. Consideration of Award of Contract No. CITY-1528, Annual Pavement Rehabilitation FY 23, to All American Asphalt in an amount not to exceed \$6,580,357.50 and adopt Notice of Exemption regarding same

**RECOMMENDED ACTION:** Award the contract to All American Asphalt, in the amount of \$6,580,357.50

- 6.5. Consideration of authorization to advertise for public bids for Contract No. CITY-1439, San Jose Reconstruction from 500 feet West of Nogales Street to 500 feet West of Charlie Road, for an estimated cost of \$5,397,000.00 (MP 08-09)

**RECOMMENDED ACTION:** Approve the plans and specifications and authorize the solicitation of the public bids.

- 6.6. Consideration of Award of Contract No. CITY-1531, Grand Avenue Slope Reconstruction and Pavement Rehabilitation from Baker Parkway to Ferrero Parkway, to Sol Construction, Inc., in an amount not to exceed \$1,876,542.00, and adopt a Notice of Exemption regarding same
- RECOMMENDED ACTION: Award the contract to Sol Construction Inc., in an amount not to exceed \$1,876,542.00, and adopt a Notice of Exemption regarding same*
- 6.7. Consideration of a Professional Services Agreement with Stillwater Ecosystem, Watershed & Riverine Sciences, to provide environmental design services, for the Follows Camp Ecological Design and Implementation Project, in an amount not-to-exceed \$757,200.00, through February 28, 2027
- RECOMMENDED ACTION: Approve the Amendment*
- 6.8. Consideration of a Professional Services Agreement with Mark Thomas & Company, Inc., to provide structural engineering design services, for the Follows Camp Ecological Design and Implementation Project, in an amount of \$363,900.00, through February 28, 2027
- RECOMMENDED ACTION: Approve the Amendment*
- 6.9. Consideration of Amendment No. 3 to the Professional Services Agreement with Kleinfelder, Inc., for on-call geotechnical engineering services, extending the term through April 30, 2028, revising the rate schedule, and increasing compensation by \$400,000.00
- RECOMMENDED ACTION: Approve the Amendment*
- 6.10. Consideration of a Public Health Services Contract with the County of Los Angeles for public health services
- RECOMMENDED ACTION: Approve the Agreement*

## **7. ACTION ITEMS**

- 7.1. Introduction and Consideration of Ordinance No. 835 AN ORDINANCE OF THE CITY COUNCIL OF THE CITY OF INDUSTRY, CALIFORNIA, REPEALING ORDINANCE NO. 823 AND APPROVING AN ADJUSTMENT TO THE MONTHLY COMPENSATION FOR THE MEMBERS OF THE CITY COUNCIL
- RECOMMENDED ACTION: 1) Waive the reading of Ordinance No. 835 and read by title only; and 2) Introduce Ordinance No. 835 an ordinance of the city council of the city of industry, California, repealing ordinance No. 823 and approving an adjustment to the monthly compensation for the members of the City Council*

- 7.2. Consideration of an Agreement with the County of Los Angeles Fire Department for the Tonner Canyon South Vegetation Management Program

*RECOMMENDED ACTION: Provide direction to Staff.*

**8. PUBLIC HEARINGS-NONE**

**9. CLOSED SESSION**

- 9.1. CONFERENCE WITH REAL PROPERTY NEGOTIATORS  
Pursuant to Government Code Section 54956.8

Property: 1 Industry Hills Parkway, City of Industry, CA, 91744 also known as Assessor Parcel Numbers (portion of) 8247-014-900, (portion of) 8247-013- 908, 8262-001-900, 8262-001-902, (portion of) 8262-011-930, 8262-011- 931, 8262-012-270, 8262-012- 271, 8262-012-272, 8262-012-273, (portion of) 8262-012-274, (portion of) 8262-012- 275, 8262-012-276,(portion of) 8262- 015-900, (portion of) 8262-015-901, 8262-015-902, 8262-015-904, (portion of) 8262-015-905, 8263-008-270, 8263- 008-271, 8263-008-904 and 8263-027- 270

Agency Negotiators: Joshua Nelson, City Manager  
James M. Casso, City Attorney

Negotiating Parties: Majestic Industry Hills, LLC, a Delaware limited liability company

Under Negotiation: Price and terms of payment

- 9.2. CONFERENCE WITH LEGAL COUNSEL - EXISTING LITIGATION  
Pursuant to Government Code Section 54956.9(d)(1)

Case: City of Industry v. Legacy Point, LLC  
Los Angeles County Superior Court Case No. 25STCV03700

- 9.3. CONFERENCE WITH LEGAL COUNSEL – ANTICIPATED LITIGATION  
Significant exposure to litigation; Pursuant to Government Code Section 54956.9(d)(2) Two potential case

- 9.4. PUBLIC EMPLOYMENT PERFORMANCE EVALUATION  
Pursuant to Government Code Section 54957(b)(1)  
TITLE: CITY TREASURER

- 9.5. *CONFERENCE WITH LEGAL COUNSEL- EXISTING LITIGATION*  
Pursuant to Government Code Section 54956.9(d)(1)

*Case: Cruz v. Radecki, et al*  
Case No.: Los Angeles Superior Court Case No. 24STCV16690

- 9.6. CONFERENCE WITH LEGAL COUNSEL – ANTICIPATED LITIGATION  
Significant exposure to litigation; Pursuant to Government Code Section 54956.9(d)(1) One potential case

10. **CITY MANAGER REPORTS**
11. **AB 1234 REPORTS**
12. **CITY COUNCIL COMMUNICATIONS**
13. **PUBLIC COMMENTS**
14. Adjournment. The next regular City Council Meeting is May 08, 2025 at 9:00 AM.

ITEM NO. 6.1

**CITY OF INDUSTRY  
AUTHORIZATION FOR PAYMENT OF BILLS  
CITY COUNCIL MEETING OF APRIL 24, 2025**

**FUND RECAP:**

<u>FUND</u>	<u>DESCRIPTION</u>	<u>DISBURSEMENTS</u>
100	GENERAL FUND	3,116,002.08
103	PROP A FUND	6,232.38
120	CAPITAL IMPROVEMENTS	465,497.39
TOTAL ALL FUNDS		3,587,731.85

**BANK RECAP:**

<u>BANK</u>	<u>NAME</u>	<u>DISBURSEMENTS</u>
BOFA	BANK OF AMERICA - CKING ACCOOUNT	6,279.86
PROP/A	PROP A - CKING ACCOUNT	6,232.38
WFBK	WELLS FARGO - CKING ACCOUNT	3,575,219.61
TOTAL ALL BANKS		3,587,731.85

APPROVED PER CITY MANAGER



DATE

4/16/25

**CITY OF INDUSTRY  
BANK OF AMERICA  
April 24, 2025**

Check	Date	Payee Name	Check Amount
-------	------	------------	--------------

**CITYGEN.CHK - City General**

Check	Date	Payee Name	Check Amount
<b>WT1413</b>	04/14/2025	<b>JOHN HANCOCK USA</b>	<b>\$6,279.86</b>
Invoice	Date	Description	Amount
3/15/25-3/28/25	04/14/2025	PARS CONTRIBUTIUONS FOR 3/15/25-3/28/25	\$6,279.86

Checks	Status	Count	Transaction Amount
	Total	1	\$6,279.86

**CITY OF INDUSTRY  
PROP A  
April 24, 2025**

Check	Date	Payee Name		Check Amount
<b>PROPA.CHK - Prop A Checking</b>				
90672	04/16/2025	WALNUT VALLEY WATER DISTRICT		\$37.15
	Invoice	Date	Description	Amount
	5294028	04/09/2025	3/1-3/31/25 SVC-PLATFORM METROLINK BREA CYN RD	\$37.15
90673	04/24/2025	INDUSTRY SECURITY SERVICES		\$5,564.80
	Invoice	Date	Description	Amount
	SG-ML-2032	04/04/2025	SECURITY SVC-METROLINK	\$2,782.40
	SG-ML-2033	04/11/2025	SECURITY SVC-METROLINK	\$2,782.40
90674	04/24/2025	JANUS PEST MANAGEMENT		\$75.00
	Invoice	Date	Description	Amount
	282591	04/07/2025	PEST SVC-METROLINK	\$75.00
90675	04/24/2025	VALLEY VISTA SERVICES, INC		\$555.43
	Invoice	Date	Description	Amount
	2164529	04/01/2025	DISP SVC-METROLINK	\$555.43

Checks	Status	Count	Transaction Amount
	Total	4	\$6,232.38

**CITY OF INDUSTRY  
WELLS FARGO WIRE TRANSFERS  
April 24, 2025**

Check	Date	Payee Name			Check Amount
<b>CITY.WF.CHK - City General Wells Fargo</b>					
WT10071	04/09/2025	INDUSTRY PROPERTY & HOUSING AU			\$27,000.00
	Invoice	Date	Description	Amount	
	4/9/2025	04/09/2025	TRANSFER FUNDS-IPHMA REG 4/9/25	\$27,000.00	

Checks	Status	Count	Transaction Amount
	Total	1	\$27,000.00

**CITY OF INDUSTRY  
WELLS FARGO VOIDED CHECKS  
April 24, 2025**

Check	Date	Payee Name	Check Amount
-------	------	------------	--------------

**CITY.WF.CHK - City General Wells Fargo**

<b>82844</b>	05/01/2024		04/15/2025	L A COUNTY REGISTRAR-RECORDER/	(\$75.00)
	Invoice	Date	Description	Amount	
			VOIDED-STALE DATED		
	4/23/2024	04/23/2024	FILING FEE-NOTICE OF EXEMPTION FOR ORDINANCE		(\$75.00)
<hr/>					
<b>83850</b>	10/10/2024		04/15/2025	LORENZO VARGAS	(\$65.00)
	Invoice	Date	Description	Amount	
			VOIDED-CK NEVER RECEIVED		
	9/26/2024	09/26/2024	REFUND CITATION # ID152449		(\$65.00)

Checks	Status	Count	Transaction Amount
	Total	1007	(\$140.00)

**CITY OF INDUSTRY  
WELLS FARGO BANK  
April 24, 2025**

Check	Date		Payee Name	Check Amount
<b>CITY.WF.CHK - City General Wells Fargo</b>				
84941	04/09/2025		<b>AIRESPRING INC</b>	\$1,366.20
	Invoice	Date	Description	Amount
	195017968	03/16/2025	INTERNET SVC-HOMESTEAD	\$1,366.20
84942	04/09/2025		<b>DIRECTV - FOR BUSINESS</b>	\$113.25
	Invoice	Date	Description	Amount
	034740128X250331	03/31/2025	RSN/TV ACCESS FEES	\$113.25
84943	04/09/2025		<b>GRANITE TELECOMMUNICATIONS, LL</b>	\$344.40
	Invoice	Date	Description	Amount
	692192433	04/01/2025	PHONE SVC FOR FIRE ALARMS-HOMESTEAD	\$344.40
84944	04/09/2025		<b>PURCHASE POWER</b>	\$200.00
	Invoice	Date	Description	Amount
	4/6/2025	04/06/2025	POSTAGE REFILL ON 4/2/25	\$200.00
84945	04/09/2025		<b>SPARKLETTS</b>	\$224.31
	Invoice	Date	Description	Amount
	21654939 040425	04/04/2025	WATER DELIVERY	\$224.31
84946	04/09/2025		<b>TPX COMMUNICATIONS</b>	\$4,597.72
	Invoice	Date	Description	Amount
	184951916-0	03/31/2025	INTERNET SVC-CITY HALL/METRO SOLAR	\$4,597.72
84947	04/09/2025		<b>TPX COMMUNICATIONS</b>	\$671.96
	Invoice	Date	Description	Amount
	184935442-0	03/31/2025	TEL/INTERNET-HOMESTEAD	\$671.96

**CITY OF INDUSTRY  
WELLS FARGO BANK  
April 24, 2025**

Check	Date		Payee Name	Check Amount
<b>CITY.WF.CHK - City General Wells Fargo</b>				
<b>84948</b>	04/09/2025		<b>INDUSTRY PUBLIC UTILITIES</b>	<b>\$1,324.64</b>
	Invoice	Date	Description	Amount
	2025-00001644	04/01/2025	1/16-3/17/25 SVC-VALLEY & 7TH (IRRI)	\$1,324.64
<b>84949</b>	04/09/2025		<b>ROWLAND WATER DISTRICT</b>	<b>\$3,313.22</b>
	Invoice	Date	Description	Amount
	2025-00001635	03/26/2025	2/5-3/4/25 SVC-AZUSA AVE - RC	\$111.51
	2025-00001636	03/26/2025	2/5-3/4/25 SVC-755 NOGALES AT - RC	\$283.03
	2025-00001637	03/26/2025	2/5-3/4/25 SVC-909 U NOGALES ST - IRR	\$148.60
	2025-00001638	03/26/2025	2/5-3/4/25 SVC-1100 S AZUSA AVE	\$199.49
	2025-00001639	03/26/2025	2/5-3/4/25 SVC-1123 HATCHER ST STE D	\$89.80
	2025-00001640	03/26/2025	2/5-3/4/25 SVC-1135 HATCHER AVE	\$56.20
	2025-00001641	03/26/2025	2/5-3/4/25 SVC-1123 HATCHER ST STE C	\$64.60
	2025-00001642	03/26/2025	2/5-3/4/25 SVC-1015 NOGALES ST - PUMP HOUSE	\$347.96
	2025-00001643	03/26/2025	2/5-3/4/25 SVC-1023 NOGALES ST - IRR	\$64.60
	2025-00001670	03/26/2025	2/5-3/4/25 SVC-AZUSA AVE	\$107.43
	2025-00001671	03/26/2025	2/5-3/4/25 SVC-AZUSA AVE - CENTER	\$62.06
	2025-00001672	03/26/2025	2/5-3/4/25 SVC-930 S AZUSA AVE	\$483.19
	2025-00001673	03/26/2025	2/5-3/4/25 SVC-17401 E VALLEY BLVD	\$721.76
	2025-00001674	03/26/2025	2/5-3/4/25 SVC-18044 ROWLAND ST	\$123.40
	2025-00001675	03/26/2025	2/5-3/4/25 SVC-HURLEY ST & VALLEY BLVD	\$449.59
<b>84950</b>	04/09/2025		<b>SAN GABRIEL VALLEY WATER CO.</b>	<b>\$0.85</b>
	Invoice	Date	Description	Amount
	2025-00001661	03/31/2025	2/27-3/28/25 SVC-IRRIG SALT LAKE/SEVENTH	\$0.85

**CITY OF INDUSTRY  
WELLS FARGO BANK  
April 24, 2025**

Check	Date		Payee Name	Check Amount
<b>CITY.WF.CHK - City General Wells Fargo</b>				
<b>84951</b>	<b>04/09/2025</b>		<b>SOCALGAS</b>	<b>\$199.92</b>
	Invoice	Date	Description	Amount
	2025-00001653	04/02/2025	2/28-3/31/25 SVC-710 NOGALES ST	\$38.94
	2025-00001662	04/02/2025	2/28-3/31/25 SVC-1015 NOGALES ST	\$33.89
	2025-00001663	03/26/2025	2/21-3/24/25 SVC-15415 E DON JULIAN RD	\$127.09
<b>84952</b>	<b>04/09/2025</b>		<b>SOUTHERN CALIFORNIA EDISON</b>	<b>\$57,932.34</b>
	Invoice	Date	Description	Amount
	2025-00001650	04/01/2025	3/1-3/31/25 SVC-600 S BREA CYN A-METROLINK	\$25.68
	2025-00001651	04/01/2025	3/1-3/31/25 SVC-600 S BREA CYN	\$363.10
	2025-00001652	04/02/2025	3/4-4/1/25 SVC-15625 MAYOR DAVE WAY	\$6,538.46
	2025-00001654	04/01/2025	3/1-3/31/25 SVC-VARIOUS SITES	\$9,458.09
	2025-00001655	03/25/2025	2/24-3/24/25 SVC-VARIOUS SITES	\$502.02
	2025-00001656	04/01/2025	3/1-3/31/25 SVC-VARIOUS SITES	\$27,393.66
	2025-00001657	04/01/2025	3/1-3/31/25 SVC-133 N AZUSA AVE	\$66.98
	2025-00001658	04/01/2025	3/1-3/31/25 SVC-NOGALES ST/SAN JOSE AVE	\$196.64
	2025-00001659	04/01/2025	3/1-3/31/25 SVC-1 VALLEY/AZUSA	\$28.60
	2025-00001660	04/01/2025	3/1-3/31/25 SVC-VARIOUS SITES	\$212.29
	2025-00001668	03/31/2025	2/13-3/16/25 SVC-VARIOUS SITES	\$2,534.23
	2025-00001669	04/01/2025	3/1-3/31/25 SVC-VARIOUS SITES	\$10,612.59
<b>84953</b>	<b>04/09/2025</b>		<b>SUBURBAN WATER SYSTEMS</b>	<b>\$777.18</b>
	Invoice	Date	Description	Amount
	180023129953	03/26/2025	2/25-3/25/25 SVC-AZUSA & GEMINI	\$434.38
	180062086607	04/02/2025	3/5-4/1/25 SVC-NE CNR VALLEY/STIMS	\$269.24
	180042482988	03/24/2025	2/22-3/24/25 SVC-205 HUDSON AVE	\$73.56

**CITY OF INDUSTRY  
WELLS FARGO BANK  
April 24, 2025**

Check	Date	Payee Name		Check Amount
<b>CITY.WF.CHK - City General Wells Fargo</b>				
84954	04/16/2025	AT & T		\$8.60
	Invoice	Date	Description	Amount
	2025-00001679	04/01/2025	4/1-4/30/25 SVC-CITY WHITE PGS LISTING	\$8.60
84955	04/16/2025	AT & T		\$7,113.19
	Invoice	Date	Description	Amount
	3591740010	03/29/2025	3/29-4/28/25 SVC-METROLINK T1 CIRCUIT	\$7,113.19
84956	04/16/2025	FRONTIER		\$1,504.38
	Invoice	Date	Description	Amount
	2025-00001681	04/01/2025	4/1-4/30/25 SVC-VARIOUS SITES	\$1,277.78
	2025-00001682	04/02/2025	4/2-5/1/25 SVC-IH GOLF COURSE FUEL PUMP	\$148.48
	2025-00001683	04/02/2025	4/2-5/1/25 SVC-1015 NOGALES ST	\$78.12
84957	04/16/2025	SAN GABRIEL VALLEY WATER CO.		\$8,865.09
	Invoice	Date	Description	Amount
	2025-00001690	03/31/2025	2/27-3/28/25 SVC-CROSSROADS PKWY S	\$700.07
	2025-00001691	03/31/2025	2/27-3/28/25 SVC-ST A 103-80 CROSSROADS PKWY S	\$247.34
	2025-00001692	03/31/2025	2/27-3/28/25 SVC-CROSSROADS PKWY S	\$2,817.18
	2025-00001693	03/31/2025	2/27-3/28/25 SVC-CROSSROADS PKWY N	\$1,932.58
	2025-00001694	03/31/2025	2/27-3/28/25 SVC-ST A 129-00 CROSSROADS PKWY N	\$730.77
	2025-00001695	03/31/2025	2/27-3/28/25 SVC-ST A 111-50 CROSSROADS PKWY N	\$253.26
	2025-00001696	03/31/2025	2/27-3/28/25 SVC-PELLISSIER	\$405.41
	2025-00001697	03/31/2025	2/27-3/28/25 SVC-PELLISSIER	\$294.39
	2025-00001698	03/31/2025	2/27-3/28/25 SVC-S/E COR OF PELLISSIER	\$1,219.00
	2025-00001699	03/31/2025	2/27-3/28/25 SVC-PELLISSIER	\$265.09

**CITY OF INDUSTRY  
WELLS FARGO BANK  
April 24, 2025**

Check	Date	Payee Name		Check Amount
<b>CITY.WF.CHK - City General Wells Fargo</b>				
<b>84958</b>	04/16/2025	<b>SOCALGAS</b>		<b>\$1,547.25</b>
	Invoice	Date	Description	Amount
	2025-00001684	04/08/2025	3/6-4/4/25 SVC-15633 RAUSCH RD	\$712.47
	2025-00001685	04/08/2025	3/6-4/4/25 SVC-15651 MAYOR DAVE WAY	\$573.42
	2025-00001703	04/08/2025	3/6-4/4/25 SVC-15625 MAYOR DAVE WAY APT B	\$261.36
<b>84959</b>	04/16/2025	<b>SOUTHERN CALIFORNIA EDISON</b>		<b>\$819.03</b>
	Invoice	Date	Description	Amount
	2025-00001677	04/04/2025	3/6-4/3/25 SVC-1123 HATCHER AVE STE-A	\$468.35
	2025-00001678	04/04/2025	3/1-3/31/25 SVC-600S BREA CYN-METROLINK	\$94.28
	2025-00001686	04/10/2025	3/12-4/9/25 SVC-504 S 6TH AVE U TC1	\$28.05
	2025-00001687	04/10/2025	3/12-4/9/25 SVC-490 S 7TH AVE	\$105.80
	2025-00001688	04/09/2025	3/11-4/8/25 SVC-575 BALDWIN PARK BLVD U	\$106.11
	2025-00001689	04/09/2025	3/11-4/8/25 SVC-122 N PUENTE AVE U1	\$16.44
<b>84960</b>	04/16/2025	<b>T-MOBILE</b>		<b>\$117.00</b>
	Invoice	Date	Description	Amount
	983372277-33	04/08/2025	3/1-3/31/25 SVC-YAL & TONNER CYN HOT SPOT	\$117.00
<b>84961</b>	04/16/2025	<b>THREE VALLEYS MUNICIPAL WATER I</b>		<b>\$2,111.03</b>
	Invoice	Date	Description	Amount
	6703	03/31/2025	3/1-3/31/25 SVC-TONNER CYN	\$2,111.03
<b>84962</b>	04/16/2025	<b>VERIZON BUSINESS</b>		<b>\$193.07</b>
	Invoice	Date	Description	Amount
	66561621	04/10/2025	3/1-3/31/25 SVC-VARIOUS SITES	\$145.86
	66561620	04/10/2025	3/1-3/31/25 SVC-VARIOUS SITES	\$47.21

**CITY OF INDUSTRY  
WELLS FARGO BANK  
April 24, 2025**

Check	Date	Payee Name		Check Amount
<b>CITY.WF.CHK - City General Wells Fargo</b>				
<b>84963</b>	04/16/2025	<b>VERIZON WIRELESS - LA</b>		<b>\$1,333.72</b>
	Invoice	Date	Description	Amount
	6109513305	03/26/2025	2/27-3/26/25 SVC-VARIOUS WIRELESS SVC	\$1,333.72
<b>84964</b>	04/16/2025	<b>WALNUT VALLEY WATER DISTRICT</b>		<b>\$2,945.72</b>
	Invoice	Date	Description	Amount
	5294009	04/09/2025	3/1-3/31/25 SVC-PUMP STN N/W CHERYL LN MAYO	\$51.59
	5294029	04/09/2025	3/1-3/31/25 SVC-PUMP MSTN BREA CYN	\$41.61
	5294263	04/09/2025	3/1-3/31/25 SVC-NOGALES PUMP STN	\$87.65
	5293098	04/09/2025	3/1-3/31/25 SVC-IRR 820 FAIRWAY DR	\$87.65
	5293149	04/09/2025	3/1-3/31/25 SVC-LEMON AVE N OF CURRIER RD	\$142.03
	5293264	04/09/2025	3/1-3/31/25 SVC-60 FWY INTERCHANGE FAIRWAY DR	\$42.47
	5293184	04/09/2025	3/1-3/31/25 SVC-BREA CYN RD & OLD RANCH RD	\$78.19
	5293200	04/09/2025	3/1-3/31/25 SVC-FERRERO & GRAND EAST RAMP	\$1,058.55
	5293245	04/09/2025	3/1-3/31/25 SVC-21350 VALLEY-MEDIAN	\$62.23
	5293246	04/09/2025	3/1-3/31/25 SVC-GRAND CROSSING EAST	\$64.89
	5293247	04/09/2025	3/1-3/31/25 SVC-GRAND CROSSING WEST	\$70.21
	5293248	04/09/2025	3/1-3/31/25 SVC-BAKER PKWY & GRAND N/W CNR	\$335.03
	5293255	04/09/2025	3/1-3/31/25 SVC-E/S GRAND S/O BAKER PKWY	\$146.17
	5293261	04/09/2025	3/1-3/31/25 SVC-BREA CYN N OF RR TRKS	\$470.73
	5293262	04/09/2025	3/1-3/31/25 SVC-BREA CYN N OF CURRIER	\$146.21
	5294276	04/09/2025	3/1-3/31/25 SVC-1004 U FAIRWAY DR GRADE SEP	\$60.51
<b>84965</b>	04/24/2025	<b>100% AUTO CARE &amp; DETAILED</b>		<b>\$580.00</b>
	Invoice	Date	Description	Amount
	154	04/02/2025	CAR WASH SVC-CITY VEHICLES	\$330.00

**CITY OF INDUSTRY  
WELLS FARGO BANK  
April 24, 2025**

Check	Date		Payee Name	Check Amount
<b>CITY.WF.CHK - City General Wells Fargo</b>				
153	03/17/2025		CAR WASH SVC-CITY VEHICLES	\$250.00
<b>84966</b>	04/24/2025		<b>A-1 SATELLITE TV</b>	<b>\$425.00</b>
Invoice	Date	Description	Amount	
23043	03/20/2025	INSTALLATION OF DIRECTV SVE-CITY HALL	\$425.00	
<b>84967</b>	04/24/2025		<b>ACORN TECHNOLOGY SERVICES</b>	<b>\$22,840.00</b>
Invoice	Date	Description	Amount	
12293	04/01/2025	NETWORK MAINT	\$22,840.00	
<b>84968</b>	04/24/2025		<b>ADVANTEC CONSULTING ENGINEERS</b>	<b>\$4,020.00</b>
Invoice	Date	Description	Amount	
9803-0230-27	04/11/2025	INTELLIGENT TRANSPORTATION SYSTEM	\$4,020.00	
<b>84969</b>	04/24/2025		<b>AMAZON WEB SERVICES, INC</b>	<b>\$4,525.26</b>
Invoice	Date	Description	Amount	
2103009553	04/01/2025	AWS SVC-MAR 2025	\$4,525.26	
<b>84970</b>	04/24/2025		<b>ANDRUES/PODBERESKY, APLC</b>	<b>\$30,076.00</b>
Invoice	Date	Description	Amount	
03727	04/01/2025	LEGAL SVC-MAR 2025	\$30,076.00	
<b>84971</b>	04/24/2025		<b>ANNEALTA GROUP</b>	<b>\$95,104.00</b>
Invoice	Date	Description	Amount	
497-3522	03/10/2025	GENERAL DEV SVC-FEB 2025	\$37,545.50	
497-3524	03/10/2025	GENERAL PLANNING SVC-FEB 2025	\$51,839.50	
497-3468	01/10/2025	184 S 6TH ST	\$166.00	

**CITY OF INDUSTRY  
WELLS FARGO BANK  
April 24, 2025**

Check	Date		Payee Name	Check Amount
<b>CITY.WF.CHK - City General Wells Fargo</b>				
	497-3469	01/10/2025	17855 ARENTH AVE	\$166.00
	497-3470	01/10/2025	16425 GALE AVE	\$2,394.00
	497-3471	01/10/2025	17550 CASTLETON ST	\$1,936.00
	497-3472	01/10/2025	200 OLD RANCH RD	\$1,057.00
<b>84972</b>	04/24/2025		<b>CALIFORNIA CONSULTING, INC.</b>	<b>\$4,750.00</b>
	Invoice	Date	Description	Amount
	7314	04/01/2025	GRANT WRITING AND MGMT SVC	\$4,750.00
<b>84973</b>	04/24/2025		<b>CASSO &amp; SPARKS, LLP</b>	<b>\$199,576.85</b>
	Invoice	Date	Description	Amount
	21073	04/14/2025	COI-LEGAL FEES FOR MAR 2025	\$197,865.85
	21073-A	04/14/2025	LEGAL FEES-20701 E. CURRIER RD	\$1,711.00
<b>84974</b>	04/24/2025		<b>CINTAS CORPORATION LOC 693</b>	<b>\$438.96</b>
	Invoice	Date	Description	Amount
	9314834342	03/31/2025	LEASE FOR AED MACHINE-HOMESTEAD	\$123.19
	4226508129	04/07/2025	DOOR MATS	\$100.60
	5264164508	04/11/2025	FIRST AID SUPPLIES	\$114.57
	4227271178	04/14/2025	DOOR MATS	\$100.60
<b>84975</b>	04/24/2025		<b>CITY OF INDUSTRY</b>	<b>\$166.99</b>
	Invoice	Date	Description	Amount
	2025-00000051	03/31/2025	IH FUELS PUMP-CITY HALL VEHICLES	\$166.99
<b>84976</b>	04/24/2025		<b>CITY OF INDUSTRY-PAYROLL ACCT</b>	<b>\$175,000.00</b>
	Invoice	Date	Description	Amount

**CITY OF INDUSTRY  
WELLS FARGO BANK  
April 24, 2025**

Check	Date		Payee Name	Check Amount
<b>CITY.WF.CHK - City General Wells Fargo</b>				
	PR P/E 3/28/25	04/07/2025	REPLENISH PAYROLL P/E 3/28/25	\$175,000.00
<b>84977</b>	04/24/2025		<b>CITY OF WHITTIER</b>	<b>\$1,617.81</b>
	Invoice	Date	Description	Amount
	8020000905	05/04/2024	CITY'S SHARE OF COST FOR ZERO BAIL PROGRAM	\$1,617.81
<b>84978</b>	04/24/2025		<b>CNC ENGINEERING</b>	<b>\$204,298.75</b>
	Invoice	Date	Description	Amount
	512259	04/10/2025	SOLAR INSTALLATION AT CITY HALL	\$7,047.50
	512260	04/10/2025	CITYWIDE ADA SELF-EVALUATION/TRANSITION PLAN	\$570.00
	512261	04/10/2025	GALE AVE REALIGNMENT	\$3,795.00
	512262	04/10/2025	PRELIMINARY DESIGN OF EW BICYCLE PATH	\$6,192.50
	512263	04/10/2025	PRELIMINARY DESIGN OF EW BICYCLE PATH	\$7,227.50
	512264	04/10/2025	GENERAL ENG SVC-1600 AZUSA AVE	\$285.00
	512265	04/10/2025	GENERAL ENG SVC-TRAFFIC SIGNAL LIGHTS UPGRAC	\$4,612.50
	512266	04/10/2025	GENERAL ENG SVC-TRAFFIC	\$3,460.00
	512267	04/10/2025	GENERAL ENG SVC 3/24-4/6/25	\$480.00
	512268	04/10/2025	GENERAL ENG SVC-COUNTER SERVICE	\$142.50
	512269	04/10/2025	GENERAL ENG SVC-PLAN APPROVAL	\$11,142.50
	512270	04/10/2025	GENERAL ENG SVC-PERMITS	\$26,308.75
	512271	04/10/2025	GENERAL ENG SVC-STREET LIGHTS	\$5,620.00
	512272	04/10/2025	GENERAL ENG SVC 3/24-4/6/25	\$87,771.25
	512273	04/10/2025	GENERAL ENG SVC-STREET LIGHT IMPROVE AT PRO	\$150.00
	512274	04/10/2025	SEWER MANAGEMENT SYSTEM	\$885.00
	512275	04/10/2025	TONNER CYN PROPERTY	\$185.00
	512276	04/10/2025	COLIMA RD WIDENING	\$2,213.75
	512277	04/10/2025	NELSON AVE RESURFACING	\$370.00

**CITY OF INDUSTRY  
WELLS FARGO BANK  
April 24, 2025**

Check	Date	Payee Name	Check Amount
<b>CITY.WF.CHK - City General Wells Fargo</b>			
512278	04/10/2025	CIVIC CENTER PLANNING AND IMPROVEMENTS	\$8,437.50
512279	04/10/2025	CITY ADMINISTRATIVE OFFICES	\$6,855.00
512280	04/10/2025	INDUSTRY BUSINESS COUNCIL CHAMBERS	\$217.50
512281	04/10/2025	CITY COUNCIL CHAMBER & IBC BUILDING IMPROVEME	\$2,082.50
512282	04/10/2025	HOMESTEAD MUSEUM IMPROVEMENTS	\$860.00
512283	04/10/2025	HOMESTEAD MUSEUM UPGRADES	\$2,137.50
512284	04/10/2025	HOMESTEAD MUSEUM IRRIGATION RETROFIT TO REC	\$460.00
512285	04/10/2025	SAFETY UPGRADES AT VARIOUS RAILROAD CROSSIN	\$582.50
512286	04/10/2025	STIMSON AVE CROSSING	\$142.50
512287	04/10/2025	SIGNING & STRIPING IMPROVEMENTS	\$1,380.00
512288	04/10/2025	SHERIFF TRAILER SITE	\$350.00
512289	04/10/2025	METROLINK-MAINT OF PARKING LOT	\$1,600.00
512290	04/10/2025	FIRE DAMAGE REPAIR OF EV AND SOLAR ENERGY	\$6,075.00
512291	04/10/2025	EL ENCANTO IMPROVEMENTS AND MAINT	\$4,660.00
<b>84979</b>	<b>04/24/2025</b>	<b>CNC ENGINEERING</b>	<b>\$140,112.50</b>
Invoice	Date	Description	Amount
512292	04/10/2025	SAN JOSE AVE RECONSTRUCTION	\$18,770.00
512293	04/10/2025	INDUSTRY HILLS FUEL STN MAINT	\$435.00
512294	04/10/2025	605 FWY AND VALLEY BLVD INTERCHANGE	\$2,592.50
512295	04/10/2025	HIGHWAY BRIDGE PROGRAM FUNDING	\$2,473.75
512296	04/10/2025	FISCAL YEAR BUDGET	\$7,250.00
512297	04/10/2025	BIXBY DR PCC PAVEMENT	\$1,940.00
512298	04/10/2025	PROPERTY AT 23400-23600, 23800 EAST FORK ROAD	\$1,441.25
512299	04/10/2025	FOLLOW'S CAMP PROJECT	\$295.00
512300	04/10/2025	VARIOUS ASSIGNMENTS RELATED TO SA	\$1,125.00
512301	04/10/2025	NELSON AVE INTERSECTION	\$32,456.25

**CITY OF INDUSTRY  
WELLS FARGO BANK  
April 24, 2025**

Check	Date		Payee Name	Check Amount
<b>CITY.WF.CHK - City General Wells Fargo</b>				
512302	04/10/2025		MAINT OF 1123 HATCHER AVE	\$4,145.00
512303	04/10/2025		CARTEGRAPH MGMT	\$24,908.75
512304	04/10/2025		GRAND AVE SLOPE RECONSTRUCTION-FERRERO TO	\$1,475.00
512305	04/10/2025		ADA COMPLIANCE ON PUBLIC RIGHT OF WAY	\$4,727.50
512306	04/10/2025		DEL VALLE AND HILL STREET STORM DRAIN/STREET I	\$1,050.00
512307	04/10/2025		2022-2023 ANNUAL PAVEMENT REHABILITATION	\$735.00
512308	04/10/2025		2022-2023 ANNUAL SLURRY SEAL	\$1,025.00
512309	04/10/2025		DON JULIAN RD IMPROVEMENTS	\$175.00
512310	04/10/2025		RAILROAD STREET PAVEMENT REHABILITATION	\$6,250.00
512311	04/10/2025		9TH AVE PAVEMENT REHABILITATION	\$557.50
512312	04/10/2025		MUSEUM-HEALTH CAMPUS MASTER SITE PLANNING	\$590.00
512313	04/10/2025		CITYWIDE SIGNAGE UPDATE	\$11,965.00
512314	04/10/2025		2024-2025 ANNUAL PAVEMENT REHABILITATION	\$6,660.00
512315	04/10/2025		2024-2025 ANNUAL SLURRY SEAL	\$1,782.50
512316	04/10/2025		CALIFORNIA AVE WIDENING	\$175.00
512317	04/10/2025		NINTH AVENUE SEWER LINE IMPROVEMENTS	\$772.50
512318	04/10/2025		PAVEMENT MANAGEMENT PLAN 2022	\$460.00
512319	04/10/2025		SR57/60 CONFLUENCE IMPROVEMENT	\$460.00
512320	04/10/2025		ALAMEDA CORRIDOR PROJECT-PUENTE AVE GRADE	\$3,420.00
<b>84980</b>	<b>04/24/2025</b>		<b>CONSILIO, LLC</b>	<b>\$1,734.92</b>
	Invoice	Date	Description	Amount
	INV579485775	03/31/2025	DOCUMENT MGMT-MAR 2025	\$1,734.92
<b>84981</b>	<b>04/24/2025</b>		<b>CORELOGIC INFORMATION SOLUTION</b>	<b>\$212.18</b>
	Invoice	Date	Description	Amount
	30763775	03/31/2025	PROPERTY DATA-MAR 2025	\$212.18

**CITY OF INDUSTRY  
WELLS FARGO BANK  
April 24, 2025**

Check	Date		Payee Name	Check Amount
<b>CITY.WF.CHK - City General Wells Fargo</b>				
84982	04/24/2025		COUNTY OF LA - DEPT OF AGRICULTU	\$40,990.04
	Invoice	Date	Description	Amount
	251040	03/20/2025	WEEDS/PEST CONTROL-TRES HERMANOS	\$40,990.04
84983	04/24/2025		CRIA-EQUESTRIAN CENTER	\$1,800.00
	Invoice	Date	Description	Amount
	PAV-012325	03/01/2025	RESOURCE EVENT FOR FIRE VICTIMS RENTAL	\$1,800.00
84984	04/24/2025		D.S. EWING ARCHITECTS, INC.	\$81,137.50
	Invoice	Date	Description	Amount
	25-11751	03/24/2025	EL ENCANTO EXTERIOR ELEVATION RENOVATION	\$4,050.00
	25-11749	03/24/2025	IBC CHAMBER & BLDG IMPROVEMENT PROJ	\$38,812.50
	25-11757	12/30/2024	IBC CHAMBER & BLDG IMPROVEMENT PROJ	\$38,275.00
84985	04/24/2025		DAPEER, ROSENBLIT, AND LITVAK, LL	\$1,414.29
	Invoice	Date	Description	Amount
	24316	03/31/2025	GENERAL CODE ENFORCEMENT-MAR 2025	\$117.00
	24317	03/31/2025	SPECIALIZED LEGAL SVC-MAR 2025	\$1,297.29
84986	04/24/2025		DB SALES & SERVICE	\$11,394.50
	Invoice	Date	Description	Amount
	24070	03/13/2025	TROUBLESHOOT BOILER CONTROL BOARD-EL ENCAN	\$4,022.50
	24257	04/09/2025	REPLACE COPPER TUBES FOR BOILER-EL ENCANTO	\$7,372.00
84987	04/24/2025		DEPT OF TRANSPORTATION	\$5,439.35
	Invoice	Date	Description	Amount

**CITY OF INDUSTRY  
WELLS FARGO BANK  
April 24, 2025**

Check	Date		Payee Name	Check Amount
<b>CITY.WF.CHK - City General Wells Fargo</b>				
	SL250627	03/24/2025	MAINT OF SIGNAL AND LIGHTS (OCT-DEC 2024)	\$5,439.35
<b>84988</b>	04/24/2025		<b>DUTHIE POWER SERVICES</b>	<b>\$552.95</b>
	Invoice	Date	Description	Amount
	A140047	04/02/2025	MONTHLY MAINT-GENERATOR @ CITY HALL	\$552.95
<b>84989</b>	04/24/2025		<b>EGOSCUE LAW GROUP, INC.</b>	<b>\$900.00</b>
	Invoice	Date	Description	Amount
	14794	04/01/2025	LEGAL SVC-FOLLOW'S CAMP	\$900.00
<b>84990</b>	04/24/2025		<b>ELECTRA-MEDIA, INC</b>	<b>\$1,975.00</b>
	Invoice	Date	Description	Amount
	17722	04/06/2025	PROGRAM PUENTE HILLS AUTO DISPLAY-MAY 2025	\$475.00
	17721	04/06/2025	MAINT OF PUENTE HILLS AUTO DISPLAY-MAY 2025	\$1,500.00
<b>84991</b>	04/24/2025		<b>ELEVATE PUBLIC AFFAIRS, LLC</b>	<b>\$39,225.00</b>
	Invoice	Date	Description	Amount
	4374	04/08/2025	MEDIA CONSULTING-MAR 2025	\$15,000.00
	4377	04/08/2025	SPECIAL EVENTS CONSULTING-MAR 2025	\$5,000.00
	4370	04/07/2025	EXPENSE REIMBURSEMENT (FEB-MAR 2025)	\$19,225.00
<b>84992</b>	04/24/2025		<b>ENTERPRISE MAPS LLC</b>	<b>\$9,870.00</b>
	Invoice	Date	Description	Amount
	284	03/31/2025	AMAZON WEB SERVICES	\$5,310.00
	286	04/06/2025	AMAZON WEB SERVICES	\$4,560.00
<b>84993</b>	04/24/2025		<b>ENVIRONS, INC.</b>	<b>\$2,750.00</b>

**CITY OF INDUSTRY  
WELLS FARGO BANK  
April 24, 2025**

Check	Date		Payee Name	Check Amount
<b>CITY.WF.CHK - City General Wells Fargo</b>				
	Invoice	Date	Description	Amount
	3816	03/31/2025	LANDSCAPE DESIGN SVC-HOMESTEAD	\$2,750.00
<b>84994</b>	04/24/2025		<b>ESPY'S ELECTRICAL SERVICES INC.</b>	<b>\$1,500.00</b>
	Invoice	Date	Description	Amount
	1567	01/27/2025	URGENT RELOCATION OF RECEPTACLE-INDUSTRY HI	\$1,500.00
<b>84995</b>	04/24/2025		<b>FEDERAL EXPRESS CORP.</b>	<b>\$124.35</b>
	Invoice	Date	Description	Amount
	8-827-78408	04/11/2025	MESSENGER SVC	\$124.35
<b>84996</b>	04/24/2025		<b>FIRST AMERICAN DATA TREE, LLC</b>	<b>\$200.00</b>
	Invoice	Date	Description	Amount
	20088320325	03/31/2025	PROPERTY DATA INFORMATION	\$200.00
<b>84997</b>	04/24/2025		<b>FIRST FIRE SYSTEMS, INC.</b>	<b>\$1,823.30</b>
	Invoice	Date	Description	Amount
	MHD10820	03/03/2025	REPAIR FIRE ALARM SYSTEM-EL ENCANTO	\$1,823.30
<b>84998</b>	04/24/2025		<b>FONTANA REYCLING CENTER</b>	<b>\$500.00</b>
	Invoice	Date	Description	Amount
	4/9/2025	04/09/2025	REIMBURSEMENT FOR SALVAGE PERMIT RENEWAL	\$500.00
<b>84999</b>	04/24/2025		<b>FRAZER, LLP</b>	<b>\$15,017.50</b>
	Invoice	Date	Description	Amount
	193126	03/31/2025	COI-PROF SVC FOR MAR 2025	\$15,017.50

**CITY OF INDUSTRY  
WELLS FARGO BANK  
April 24, 2025**

Check	Date		Payee Name	Check Amount
<b>CITY.WF.CHK - City General Wells Fargo</b>				
85000	04/24/2025		FUEL PROS, INC.	\$457.50
	Invoice	Date	Description	Amount
	77974	04/03/2025	INDUSTRY HILLS FUEL STN MAINT	\$250.00
	77946	04/02/2025	INDUSTRY HILLS FUEL STN MAINT	\$207.50
85001	04/24/2025		GARCIA'S FENCE CORP	\$6,291.00
	Invoice	Date	Description	Amount
	032506	03/07/2025	REPAIR VARIOUS FENCES-TEMPLE AND AZUSA	\$6,291.00
85002	04/24/2025		GOLDEN SUN ENTERPRISE, INC.	\$88,928.97
	Invoice	Date	Description	Amount
	#4CITY-1489	04/01/2025	FIRE DAMAGE REPAIR OF EV AND SOLAR ENERGY	\$93,609.44
85003	04/24/2025		GRAND CENTRAL RECYCLING & TRAI	\$1,216.00
	Invoice	Date	Description	Amount
	2047528	03/03/2025	SOLID WASTE-CITY HALL	\$1,216.00
85004	04/24/2025		HENRY AGUILAR	\$185.00
	Invoice	Date	Description	Amount
	12	04/10/2025	ADMIN HEARING OFFICER-CITATION APPEALS	\$185.00
85005	04/24/2025		HISTORICAL RESOURCES, INC.	\$58,753.08
	Invoice	Date	Description	Amount
	COI2025-8.3	03/09/2025	REIMBURSE FOR MUSEUM ARTIFACT PURCHASE	\$351.51
	COI2025-9.3	04/10/2025	REIMBURSE FOR MUSEUM ARTIFACT PURCHASE	\$535.41
	COI2025-09	04/10/2025	ADMIN & MGMT SVC-HOMESTEAD	\$54,464.00
	COI2025-9.2	04/10/2025	EXPENSE REIMBURSEMENT-MAR 2025	\$3,402.16

**CITY OF INDUSTRY  
WELLS FARGO BANK  
April 24, 2025**

Check	Date		Payee Name	Check Amount
<b>CITY.WF.CHK - City General Wells Fargo</b>				
<b>85006</b>	04/24/2025		<b>INDUSTRY SECURITY SERVICES</b>	<b>\$67,727.92</b>
	Invoice	Date	Description	Amount
	SG-COI#2-2032	04/04/2025	SECURITY SVC-VARIOUS CITY SITES	\$23,024.36
	SG-COI#1-2032	04/04/2025	SECURITY SVC 3/28-4/3/25	\$10,839.60
	SG-COI#2-2033	04/11/2025	SECURITY SVC-VARIOUS CITY SITES	\$23,024.36
	SG-COI#1-2033	04/11/2025	SECURITY SVC 4/4-4/10/25	\$10,839.60
<b>85007</b>	04/24/2025		<b>INDUSTRY SHERIFF'S YOUTH ACTIVIT</b>	<b>\$104,000.00</b>
	Invoice	Date	Description	Amount
	4/10/2025	04/10/2025	SPONSORSHIP-YAL 32ND ANNUAL GOLF CLASSIC	\$104,000.00
<b>85008</b>	04/24/2025		<b>INTERIOR IMAGES, INC.</b>	<b>\$5,625.00</b>
	Invoice	Date	Description	Amount
	4002	12/20/2024	INTERIOR DESIGN-EL ENCANTO FACILITY	\$5,625.00
<b>85009</b>	04/24/2025		<b>JANUS PEST MANAGEMENT</b>	<b>\$2,526.00</b>
	Invoice	Date	Description	Amount
	283144	04/07/2025	PEST SVC-HOMESTEAD	\$660.00
	282566	04/07/2025	PEST SVC-IBC	\$155.00
	282565	04/07/2025	PEST SVC-CITY HALL	\$155.00
	282567	04/07/2025	PEST SVC-YAL/POST OFFICE	\$95.00
	282556	04/07/2025	PEST SVC-TONNER CYN	\$485.00
	282616	04/07/2025	RODENT SVC-HOMESTEAD	\$300.00
	282614	04/07/2025	RODENT SVC-HELIPAD PARKING LOT	\$486.00
	282792	04/07/2025	PEST SVC-205 HUDSON AVE	\$85.00
	282823	04/07/2025	MOSQUITO TRAP-EL ENCANTO	\$105.00

**CITY OF INDUSTRY  
WELLS FARGO BANK  
April 24, 2025**

Check	Date		Payee Name	Check Amount
<b>CITY.WF.CHK - City General Wells Fargo</b>				
85010	04/24/2025		KLEINFELDER, INC.	\$22,580.50
	Invoice	Date	Description	Amount
	001527419	03/28/2025	NELSON AVE INTERSECTION IMPROVEMENTS-PUENT	\$22,580.50
85011	04/24/2025		L A COUNTY DEPT OF PUBLIC WORKS	\$44,667.86
	Invoice	Date	Description	Amount
	IN250000661	03/24/2025	BLDG & SAFETY-ONE STOP SHOP FOR JAN 2025	\$44,667.86
85012	04/24/2025		L A COUNTY SHERIFF'S DEPARTMENT	\$1,126,096.65
	Invoice	Date	Description	Amount
	252527TZ	03/25/2025	SPECIAL EVENT-DIRECTED PATROL (FEB 2025)	\$53,866.98
	252646TZ	04/09/2025	SHERIFF CONTRACT-MAR 2025	\$1,072,229.67
85013	04/24/2025		LEIGHTON CONSULTING INC	\$17,633.32
	Invoice	Date	Description	Amount
	64474	10/22/2024	GEO SVC-DON JULIAN RD & TURNBULL CYN RD	\$11,555.76
	64972	11/22/2024	GEO SVC-DON JULIAN RD & TURNBULL CYN RD	\$6,077.56
85014	04/24/2025		LOCKS PLUS, INC.	\$1,445.38
	Invoice	Date	Description	Amount
	36122	03/13/2025	REPLACE KEYWAY-HOMESTEAD	\$901.43
	36126	03/27/2025	REKEY MASTER SYSTEM-HOMESTEAD	\$543.95
85015	04/24/2025		LORENZO VARGAS	\$65.00
	Invoice	Date	Description	Amount
	9/26/2024	09/26/2024	REFUND CITATION # ID152449	\$65.00

**CITY OF INDUSTRY  
WELLS FARGO BANK  
April 24, 2025**

Check	Date		Payee Name	Check Amount
<b>CITY.WF.CHK - City General Wells Fargo</b>				
85016	04/24/2025		MARISOL HERNANDEZ	\$173.27
	Invoice	Date	Description	Amount
	4/8/2025	04/08/2025	REIMBURSE FOR AUTISM AWARENESS PINS	\$173.27
85017	04/24/2025		MORTISE & TENON BUILDING CORP	\$8,223.03
	Invoice	Date	Description	Amount
	194.2	02/12/2025	REMAINING BALANCE-ROOF REPAIR @ EL ENCANTO	\$6,223.03
	252	04/08/2025	REPLACE LIGHT FIXTURES-POST OFFICE	\$2,000.00
85018	04/24/2025		OCEAN BLUE ENVIRONMENTAL SERV	\$5,149.20
	Invoice	Date	Description	Amount
	41228	03/27/2025	HAZARDOUS WASTE REMOVAL	\$3,306.54
	41207	03/26/2025	HAZARDOUS WASTE REMOVAL	\$1,842.66
85019	04/24/2025		ODP BUSINESS SOLUTIONS, LLC	\$336.43
	Invoice	Date	Description	Amount
	414838232001	03/13/2025	OFFICE SUPPLIES	\$187.47
	414839102001	03/13/2025	OFFICE SUPPLIES	\$74.37
	414839103001	03/13/2025	OFFICE SUPPLIES	\$74.59
85020	04/24/2025		PACIFIC PALMS CONFERENCE RESOF	\$13,644.54
	Invoice	Date	Description	Amount
	969529	04/09/2025	SPONSORSHIP FOR LUNCHEON FOR CONGRESSMAN	\$13,644.54
85021	04/24/2025		PACIFIC UTILITY INSTALLATION	\$91,258.05
	Invoice	Date	Description	Amount

**CITY OF INDUSTRY  
WELLS FARGO BANK  
April 24, 2025**

Check	Date		Payee Name	Check Amount
<b>CITY.WF.CHK - City General Wells Fargo</b>				
	31880	03/31/2025	CITY STREETLIGHT PROGRAM AND ACCIDENTS (OCT	\$82,327.00
	#4CITY-1507-R	04/01/2025	RETENTION-REMOTE MONITORING SYSTEM-CITYWID	\$8,931.05
<b>85022</b>	04/24/2025		<b>PARS</b>	<b>\$382.74</b>
	Invoice	Date	Description	Amount
	57006	12/05/2024	REP FEES-OCT 2024	\$382.74
<b>85023</b>	04/24/2025		<b>PLACEWORKS</b>	<b>\$35,668.88</b>
	Invoice	Date	Description	Amount
	IND-22.14-5	02/28/2025	PROPOSED BATTERY STORAGE FACILITY	\$14,513.33
	IND-22.16-5	03/31/2025	CEQA FOR 1600 AZUSA AVE	\$3,652.50
	IND-22.15-4	03/31/2025	CEQA FOR 17871 CASTLETON ST	\$3,011.25
	IND-22.14-6	03/31/2025	PROPOSED BATTERY STORAGE FACILITY	\$13,861.80
	IND-20.0-1	03/31/2025	HOUSING ELEMENT SVC	\$630.00
<b>85024</b>	04/24/2025		<b>POST ALARM SYSTEMS</b>	<b>\$363.87</b>
	Invoice	Date	Description	Amount
	1792911	04/03/2025	MONITORING SVC-HOMESTEAD	\$363.87
<b>85025</b>	04/24/2025		<b>PRICE, POSTEL &amp; PARMA, LLP</b>	<b>\$872.00</b>
	Invoice	Date	Description	Amount
	221678	04/01/2025	LEGAL SVC-MAR 2025	\$872.00
<b>85026</b>	04/24/2025		<b>PRINCE GLOBAL SOLUTIONS, LLC</b>	<b>\$5,000.00</b>
	Invoice	Date	Description	Amount
	073	04/09/2025	FEDERAL ADVOCACY-APR 2025	\$5,000.00

**CITY OF INDUSTRY  
WELLS FARGO BANK  
April 24, 2025**

Check	Date	Payee Name		Check Amount
<b>CITY.WF.CHK - City General Wells Fargo</b>				
85027	04/24/2025	PUBLIC RISK MANAGEMENT ASSOCIA		\$1,150.00
	Invoice	Date	Description	Amount
	3/5/2025	03/05/2025	PRIMA INSTITUTE CONFERENCE 2025-YVETTE	\$725.00
	4/15/2025	04/15/2025	MEMBERSHIP DUES FOR YVETTE	\$425.00
85028	04/24/2025	PUENTE BASIN WATER AGENCY		\$6,656.92
	Invoice	Date	Description	Amount
	1814	02/28/2025	GROUNDWATER MGMT PLAN PHASE 2 (FEB 2025)	\$3,389.92
	1813	01/31/2025	GROUNDWATER MGMT PLAN PHASE 2 (JAN 2025)	\$3,267.00
85029	04/24/2025	QUICK QUACK CAR WASH HOLDINGS		\$4,380.50
	Invoice	Date	Description	Amount
	4/9/2025	04/09/2025	RETURN UNUSED DEVELOPER'S DEPOSIT FOR 17411	\$4,380.50
85030	04/24/2025	RADWELL INTERNATIONAL LLC		\$8,749.48
	Invoice	Date	Description	Amount
	35211114	03/12/2025	REPLACE MAIN CONTROL BOARD-EL ENCANTO	\$8,749.48
85031	04/24/2025	REGIONAL CHAMBER OF COMMERCE		\$1,000.00
	Invoice	Date	Description	Amount
	4/1/2025	04/01/2025	SPONSORSHIP FOR HIGH SCHOOL SCHOLARSHIPS	\$1,000.00
85032	04/24/2025	RICOH USA, INC.		\$320.68
	Invoice	Date	Description	Amount
	589828091	04/06/2025	COPIER LEASE-HOMESTEAD	\$320.68
85033	04/24/2025	ROBINSON'S FLOWERS		\$132.00

**CITY OF INDUSTRY  
WELLS FARGO BANK  
April 24, 2025**

Check	Date		Payee Name	Check Amount
<b>CITY.WF.CHK - City General Wells Fargo</b>				
	Invoice	Date	Description	Amount
	3824	04/01/2025	FLOWERS AND DELIVERY	\$132.00
<b>85034</b>	04/24/2025		<b>SAN GABRIEL VALLEY CITY MANAGE</b>	<b>\$40.00</b>
	Invoice	Date	Description	Amount
	3/10/2025-A	03/10/2025	SGVCMA MEETING-SAM	\$40.00
<b>85035</b>	04/24/2025		<b>SAN GABRIEL VALLEY NEWSPAPER C</b>	<b>\$430.12</b>
	Invoice	Date	Description	Amount
	0011724196	03/13/2025	ACCT #5007735-NOTICE OF CANCELLATION OF ELECT	\$430.12
<b>85036</b>	04/24/2025		<b>SATSUMA LANDSCAPE &amp; MAINT.</b>	<b>\$180,951.09</b>
	Invoice	Date	Description	Amount
	0425EC	04/11/2025	LANDSCAPE SVC-EXPO CENTER	\$36,203.98
	0425XROADS	04/11/2025	LANDSCAPE SVC-CROSSROADS PKY NORTH & SOUTH	\$51,549.38
	0425TA	04/11/2025	LANDSCAPE SVC-TEMPLE & AZUSA	\$33,005.84
	0425CH	04/11/2025	LANDSCAPE SVC-CIVIC FINANCIAL CENTER	\$60,191.89
<b>85037</b>	04/24/2025		<b>SCS FIELD SERVICES</b>	<b>\$20,112.84</b>
	Invoice	Date	Description	Amount
	0533900	03/31/2025	INDUSTRY HILLS-LANDFILL GAS SYSTEM	\$20,112.84
<b>85038</b>	04/24/2025		<b>SO CAL INDUSTRIES</b>	<b>\$286.43</b>
	Invoice	Date	Description	Amount
	738094	03/27/2025	WC ACCESS RENTAL-TONNER CYN/57 FWY	\$195.89
	740483	04/11/2025	FENCE RENTAL-IND HILLS	\$90.54

**CITY OF INDUSTRY  
WELLS FARGO BANK  
April 24, 2025**

Check	Date		Payee Name	Check Amount
<b>CITY.WF.CHK - City General Wells Fargo</b>				
85039	04/24/2025		SPECIAL T WATER SYSTEMS, INC.	\$958.31
	Invoice	Date	Description	Amount
	244975	04/03/2025	SALT DELIVERY-EL ENCANTO	\$958.31
85040	04/24/2025		SPECTRUM	\$938.99
	Invoice	Date	Description	Amount
	188632001040725	04/07/2025	BUSINESS INTERNET-APR 2025	\$938.99
85041	04/24/2025		SQUARE ROOT GOLF & LANDSCAPE, I	\$246,369.78
	Invoice	Date	Description	Amount
	1792ELHM	04/10/2025	LANDSCAPE SVC-VARIOUS CITY SITES	\$6,598.52
	1794ELHM	04/10/2025	LANDSCAPE SVC-HOMESTEAD	\$27,871.21
	1793ELHM	04/10/2025	LANDSCAPE SVC-EL ENCANTO	\$8,829.54
	1795H-1	04/10/2025	GRAFFITI REMOVAL	\$2,577.01
	1795H-2	04/10/2025	SIGN REPAIR & INSTALLATION	\$2,577.83
	1795H	04/10/2025	LANDSCAPE SVC-VARIOUS CITY SITES	\$197,915.67
85042	04/24/2025		STATE WATER RESOURCES CONTRO	\$619.00
	Invoice	Date	Description	Amount
	SW-0317392	04/08/2025	ANNUAL PERMIT FEE-NELSON AVE INTERSECTIONS @	\$619.00
85043	04/24/2025		SUPERIOR COURT OF CA-LA COUNTY	\$2,468.50
	Invoice	Date	Description	Amount
	MARCH 2025	04/03/2025	PARKING CITATIONS REPORT-MAR 2025	\$2,468.50
85044	04/24/2025		SUPERIOR PAVEMENT MARKINGS, INC	\$77,034.55
	Invoice	Date	Description	Amount

**CITY OF INDUSTRY  
WELLS FARGO BANK  
April 24, 2025**

Check	Date		Payee Name	Check Amount
<b>CITY.WF.CHK - City General Wells Fargo</b>				
	#2CITY-1509	04/01/2025	CITYWIDE SIGN REPLACEMENT PROJECT	\$81,089.00
<b>85045</b>	04/24/2025		<b>THE TECHNOLOGY DEPOT</b>	<b>\$790.00</b>
	Invoice	Date	Description	Amount
	28278	04/01/2025	CLOUD CONNECT UNAAS-MAY 2025	\$790.00
<b>85046</b>	04/24/2025		<b>TRIMARK ASSOCIATES, INC.</b>	<b>\$30,546.50</b>
	Invoice	Date	Description	Amount
	INV2025-00467	04/10/2025	FULL COST SERVICE AGRMT-METRO SOLAR	\$30,546.50
<b>85047</b>	04/24/2025		<b>TURBO DATA SYSTEMS, INC</b>	<b>\$379.63</b>
	Invoice	Date	Description	Amount
	45361	03/31/2025	CITATION PROCESSING FEB/MAR 2025	\$379.63
<b>85048</b>	04/24/2025		<b>TYLER TECHNOLOGIES, INC.</b>	<b>\$350.00</b>
	Invoice	Date	Description	Amount
	045-513838	03/31/2025	SERVICE AGRMT-CITY'S ERP	\$350.00
<b>85049</b>	04/24/2025		<b>VALLEY VISTA SERVICES, INC</b>	<b>\$23,919.48</b>
	Invoice	Date	Description	Amount
	2082665	03/31/2025	DISP SVC-CITY HALL	\$571.53
	2082847	03/31/2025	DISP SVC-15660 MAYOR DAVE WAY (YAL)	\$159.37
	2082846	03/31/2025	DISP SVC-TONNER CYN (MAINT YD)	\$1,066.89
	2082845	03/03/2025	DISP SVC-1123 HATCHER AVE	\$5,694.79
	2082942	03/26/2025	DISP SVC-17405 GALE AVE	\$3,118.77
	2164774	04/01/2025	DISP SVC-CITY BUS STOPS	\$4,796.49
	2164431	04/01/2025	DISP SVC-CITY RESIDENTS	\$5,829.61

**CITY OF INDUSTRY  
WELLS FARGO BANK  
April 24, 2025**

Check	Date	Payee Name	Check Amount
-------	------	------------	--------------

---

**CITY.WF.CHK - City General Wells Fargo**

2164619	04/01/2025	DISP SVC-205 N HUDSON AVE	\$265.14
2165431	04/01/2025	DISP SVC-1123 HATCHER AVE	\$312.23
2165429	04/01/2025	DISP SVC-TONNER CYN (CAMP COURAGE)	\$464.35
2180617	04/01/2025	DISP SVC-FOLLOW'S CAMP	\$1,640.31

---

<b>85050</b>	04/24/2025	<b>WEST COAST ARBORISTS, INC.</b>	<b>\$30,786.55</b>
Invoice	Date	Description	Amount
227409	03/31/2025	TREE MAINT FY 24/25	\$30,786.55

---

Checks	Status	Count	Transaction Amount
<b>Total</b>		<b>110</b>	<b>\$3,548,359.61</b>

ITEM NO. 6.2



# CITY OF INDUSTRY

## MEMORANDUM

**TO:** Honorable Mayor and Members of the City Council

**FROM:** Joshua Nelson, City Manager

**STAFF:** Sam Pedroza, Asst. City Manager  
Yvette Padilla, Management Analyst II

**DATE:** April 24, 2025

**SUBJECT:** Consideration of Resolution No. CC 2025-12– A RESOLUTION OF THE CITY COUNCIL OF THE CITY OF INDUSTRY, CALIFORNIA, APPROVING A DONATION TO EAST SAN GABRIEL VALLEY COALITION FOR THE HOMELESS, IN THE AMOUNT OF TWENTY THOUSAND DOLLARS (\$20,000.00), FOR ITS HOMELESS PROGRAMS

---

### **Background:**

The East San Gabriel Valley Coalition for the Homeless (“ESGVCH”) is a non-profit 501(c)(3) charitable organization that works to directly aid families and individuals experiencing homelessness in the San Gabriel Valley. ESGVCH has been serving the community since 1994 by hosting vital programs that aid homeless families.

### **Discussion:**

The City has previously supported ESGVCH through donations and was recently contacted again with a request for continued assistance. This proposed \$20,000.00 donation will enable ESGVCH to carry on its vital work in the community, including support for families in need and collaboration with the Hacienda-La Puente Unified School District and other nearby districts. Services provided include motel vouchers, food, hygiene supplies, and case management. A small portion of the funds may be allocated for administrative costs necessary to deliver and sustain these services.

### **Fiscal Impact:**

In the Fiscal Year 2024/25 budget, \$371,000.00 was approved for Donations for Community Promotions and Economic Development. No appropriations are required at this time (Account No. 100-621-5602).

### **Recommendation:**

Staff recommends that the City Council adopt Resolution No. CC 2025-12.

**Exhibits:**

1. Resolution No. CC 2025-12

**RESOLUTION NO. CC 2025-12**

**A RESOLUTION OF THE CITY COUNCIL OF THE CITY OF INDUSTRY, CALIFORNIA, APPROVING A DONATION TO EAST SAN GABRIEL VALLEY COALITION FOR THE HOMELESS, IN THE AMOUNT OF TWENTY THOUSAND DOLLARS (\$20,000.00), FOR ITS HOMELESS PROGRAMS**

**RECITALS**

**WHEREAS**, the East San Gabriel Valley Coalition for the Homeless (“ESGVCH”) is a non-profit 501(c)(3) charitable organization that works to directly aid families and individuals experiencing homelessness in the San Gabriel Valley; and

**WHEREAS**, ESGVCH has been serving the community since 1994 by hosting vital programs that aid homeless families; and

**WHEREAS**, ESGVCH contacted the City to request a donation, and this donation of \$20,000.00 will allow them to continue to assist the community and families in need; and

**WHEREAS**, ESGVCH works closely with Hacienda-La Puente Unified School District (“HLPUSD”) and surrounding school districts to provide motel vouchers, food, hygiene items, and case management and a small portion of the donation may be used towards administration to facilitate services and continued case management; and

**WHEREAS**, the City’s donation serves a public purpose in that ESGVCH has been at the forefront of helping to fight homelessness in the San Gabriel Valley with a mission to bring hope and restore dignity to the individuals and families who are experiencing or are vulnerable to experiencing homelessness. The City’s donation will allow ESGVCH to provide valuable services to families in the area, including those with children enrolled in HLPUSD; and

**WHEREAS**, all legal prerequisites to the adoption of this Resolution have occurred.

**NOW, THEREFORE, THE CITY COUNCIL OF THE CITY OF INDUSTRY DOES HEREBY FIND, DETERMINE, AND RESOLVE AS FOLLOWS:**

**SECTION 1:** The City Council finds that all of the facts set forth in the Recitals are true and correct and are incorporated herein by reference.

**SECTION 2:** The City’s donation serves a public purpose in that ESGVCH has been at the forefront of helping to fight homelessness in the San Gabriel Valley with a mission to bring hope and restore dignity to the individuals and families who are experiencing or are vulnerable to experiencing homelessness. The City’s donation will

allow ESGVCH to provide valuable services to families in the area, including those with children enrolled in HLPUSD.

**SECTION 3:** The City Council approves a donation to East San Gabriel Valley Coalition for the Homeless in the amount of Twenty Thousand Dollars (\$20,000.00) for its homeless programs.

**SECTION 4:** The City Manager is hereby authorized and directed to take such other and further action consistent with this Resolution, in order to implement this Resolution on behalf of the City.

**SECTION 5:** The provisions of this Resolution are severable and if any provision, clause, sentence, word or part thereof is held illegal, invalid, unconstitutional, or inapplicable to any person or circumstances, such illegality, invalidity, unconstitutionality, or inapplicability shall not affect or impair any of the remaining provisions, clauses, sentences, sections, words or parts thereof of the Resolution or their applicability to other persons or circumstances.

**SECTION 6:** That the City Clerk shall certify to the adoption of this Resolution and that the same shall be in full force and effect.

**PASSED, APPROVED AND ADOPTED** by the City Council of the City of Industry at a regular meeting held on April 24, 2025, by the following vote:

AYES:	COUNCIL MEMBERS:
NOES:	COUNCIL MEMBERS:
ABSTAIN:	COUNCIL MEMBERS:
ABSENT:	COUNCIL MEMBERS:

\_\_\_\_\_  
Cory C. Moss, Mayor

**ATTEST:**

\_\_\_\_\_  
Julie Gutierrez-Robles, City Clerk

ITEM NO. 6.3



# CITY OF INDUSTRY

## MEMORANDUM

**TO:** Honorable Mayor and Members of the City Council

**FROM:** Joshua Nelson, City Manager

**STAFF:** Sam Pedroza, Asst. City Manager  
Yvette Padilla, Management Analyst II

**DATE:** April 24, 2025

**SUBJECT:** Consideration of Resolution No. CC 2025-13 – A RESOLUTION OF THE CITY COUNCIL OF THE CITY OF INDUSTRY, CALIFORNIA, APPROVING A DONATION TO PACIFIC CREST YOUTH ARTS ORGANIZATION, IN THE AMOUNT OF TEN THOUSAND DOLLARS (\$10,000.00), FOR THE PACIFIC CREST OUTREACH PROGRAM

---

### **Background:**

Pacific Crest Youth Arts Organization (“Pacific Crest”) was founded in 1993 as a non-profit organization that provides educational and competitive performing arts programs that change the lives of young people in the greater Southern California region. Pacific Crest is one of North America’s most respected performing arts programs and reaches 4,200 students each year.

### **Discussion:**

The City has previously supported Pacific Crest through donations that help students participate in performances across the region. This year’s donation will allow students to attend the Drum Corps at the Rose Bowl event on July 12, 2025, at no cost. It will also support the program’s broader mission of expanding access to music education and inspiring young people throughout the community.

### **Fiscal Impact:**

In the Fiscal Year 2024/25 budget, \$371,000.00 was approved for Donations for Community Promotions and Economic Development. No appropriations are required at this time (Account No. 100-621-5602).

### **Recommendation:**

Staff recommends that the City Council adopt Resolution No. CC 2025-13.

### **Exhibits:**

1. Resolution No. CC 2025-13

**RESOLUTION NO. CC 2025-13**

**A RESOLUTION OF THE CITY COUNCIL OF THE CITY OF INDUSTRY, CALIFORNIA, APPROVING A DONATION TO PACIFIC CREST YOUTH ARTS ORGANIZATION, IN THE AMOUNT OF TEN THOUSAND DOLLARS (\$10,000.00), FOR PACIFIC CREST OUTREACH PROGRAM**

**RECITALS**

**WHEREAS**, Pacific Crest Youth Arts Organization (“Pacific Crest”) was founded in 1993 as a non-profit organization that provides educational and competitive performing arts programs in the greater Southern California region; and

**WHEREAS**, Pacific Crest is one of North America’s most respected performing arts programs and reaches 4,200 students each year; and

**WHEREAS**, Pacific Crest requested a donation in the amount of Ten Thousand Dollars (\$10,000.00) to allow all the high school band students in the Hacienda-La Puente Unified School District to attend Drum Corps at the Rose Bowl on July 12, 2025; and

**WHEREAS**, the donation will also support Pacific Crest’s broader mission of expanding access to music education and inspiring young people throughout the community; and

**WHEREAS**, the City’s donation serves a public purpose by contributing to Pacific Crest, which supports the community by providing art programs that change the lives of young people in the greater Southern California region, and prepare them for leadership in a fast-moving world; and

**WHEREAS**, all legal prerequisites to the adoption of this Resolution have occurred.

**NOW, THEREFORE, THE CITY COUNCIL OF THE CITY OF INDUSTRY HEREBY FINDS, DETERMINES, AND RESOLVES AS FOLLOWS:**

**SECTION 1:** The City Council finds that all of the facts set forth in the Recitals are true and correct and are incorporated herein by reference.

**SECTION 2:** The City’s donation serves a public purpose by contributing to Pacific Crest, which supports the community by providing art programs that change the lives of young people in the greater Southern California region, and prepare them for leadership in a fast-moving world.

**SECTION 3:** The City Council hereby approves the donation of Ten Thousand Dollars (\$10,000.00) to Pacific Crest Youth Arts Organization.

**SECTION 4:** The City Manager is hereby authorized and directed to take such other and further action consistent with this Resolution, in order to implement this Resolution on behalf of the City.

**SECTION 5:** The provisions of this Resolution are severable and if any provision, clause, sentence, word or part thereof is held illegal, invalid, unconstitutional, or inapplicable to any person or circumstances, such illegality, invalidity, unconstitutionality, or inapplicability shall not affect or impair any of the remaining provisions, clauses, sentences, sections, words or parts thereof of the Resolution or their applicability to other persons or circumstances.

**SECTION 6:** That the City Clerk shall certify to the adoption of this Resolution and that the same shall be in full force and effect.

**PASSED, APPROVED AND ADOPTED** by the City Council of the City of Industry at a regular meeting held on April 24, 2025, by the following vote:

AYES: COUNCIL MEMBERS:

NOES: COUNCIL MEMBERS:

ABSTAIN: COUNCIL MEMBERS:

ABSENT: COUNCIL MEMBERS:

\_\_\_\_\_  
Cory C. Moss, Mayor

**ATTEST:**

\_\_\_\_\_  
Julie Gutierrez-Robles, City Clerk

ITEM NO. 6.4



# CITY OF INDUSTRY

## MEMORANDUM

**TO:** Honorable Mayor and Members of the City Council

**FROM:** Joshua Nelson, City Manager

**STAFF:** Mathew Hudson, Director of Public Works  
James Cramsie, Sr. Director of Engineering  
Arlene Lopez, Sr. Project Manager

**DATE:** April 24, 2025

**SUBJECT:** Consideration of Award of Contract No. CITY-1528, Annual Pavement Rehabilitation FY 23, to All American Asphalt in an amount not to exceed \$6,580,357.50 and adopt Notice of Exemption regarding same

---

### **Background:**

On November 14, 2024, the City Council authorized solicitation of public bids for Annual Pavement Rehabilitation FY 23 project for an estimated cost of \$7,501,000.00. This project was bid to procure a contractor to resurface various streets throughout the City and for the reconstruction of Bonelli St. Work consists mainly of cold milling existing asphalt concrete pavement ("AC") pavement, constructing AC pavement overlay, installation of asphalt rubber aggregate membrane on Gale Avenue, repair of broken curbs, gutters, driveways and sidewalks; upgrading curb ramps to current ADA standards, adjustment of existing utilities to finish grade, and installing pavement markers, markings and striping and repainting red curb throughout

On December 19, 2024, the bid was posted in the City's PlanetBids™ vendor portal and an email notification was sent to 699 vendors. The bid was viewed by 71 prospective bidders. The appropriate trade journals were notified on December 19, 2024. The bid was advertised on December 24, 2024, and December 31, 2024, in the San Gabriel Valley Tribune. Questions pertaining to the bid were received up until March 21, 2025, at 5:00 p.m. in the City's PlanetBids™ vendor portal.

### **Discussion:**

The bid process closed on April 3, 2025. Seven (7) bids were received. The review of bids has found that All American Asphalt has submitted the lowest responsive bid and has the relevant experience, qualifications, and licensing necessary to complete this project. Below is a table of all bidders and their prices.

<b>Bidder</b>	<b>Bid Price</b>
Sequel Contractors, Inc.	\$6,181,140.00
Gentry Brothers, Inc.	\$6,366,681.00
All American Asphalt	\$6,580,357.50
Hardy & Harper, Inc.	\$6,647,000.00
Sully-Miller Contracting Company	\$6,893,398.60
PALP dba Excel Paving Company	\$7,288,590.00
Toro Enterprises, Inc.	\$7,616,858.00

After the review of all bids, the apparent lowest bidder, Sequel Contractors, Inc., did not submit the proper Notary Public Acknowledgements for four of the forms. The second apparent low bidder, Gentry Brothers, Inc., also did not submit the proper Notary Public Acknowledgements for two of the forms. Therefore, the bids for these two (2) bidders are deemed to be non-responsive.

All American Asphalt is the lowest responsive bidder, and Staff recommends an award in an amount of \$6,580,357.50. Additionally, Staff recommends that the City Council authorize the City Manager to approve change orders up to 10 percent of the contract amount.

Staff has determined that this project is subject to review under the California Environmental Quality Act (“CEQA”), however, it falls within the Categorical Exemption, Section 15301 Class 1, minor alteration of existing public facilities. As set forth above, the project involves the resurfacing of Stafford Street, Hudson Avenue, Hacienda Boulevard, Gale Avenue, Castleton Street, Albatross Road, Newquist Place, Canal Place, Loudon Lane, and Temple Avenue including, cold milling of existing asphalt concrete (“AC”) pavement, constructing AC pavement overlay, repairing broken curbs, gutter, driveways, and sidewalks, upgrading curb ramps to current ADA standards, adjusting existing utilities to finish grade, pavement markings, striping and red curb throughout. Work also includes the complete reconstruction of existing AC pavement section on Bonelli Street. This Work includes the removal of existing asphalt concrete pavement and aggregate base and replacing with new AC pavement on crushed aggregate base on one layer of geogrid between subgrade and aggregate base. The project does not result in an expansion of the use, as the streets are not being expanded to allow for additional traffic, it’s simply routine maintenance work. Based on the foregoing, Staff is recommending that the City Council adopt a Notice of Exemption for the project.

**Fiscal Impact:**

The fiscal impact is \$6,580,357.50. In the adopted Fiscal Year 2024-2025 Capital Improvement Project budget, \$4,000,000.00 is approved for this project (Account No. 120-702-5205, MP 22-04). This is sufficient budget for the remainder of this fiscal year, and additional funding will be proposed in the next fiscal year budget for this project.

**Recommendation:**

1. Staff recommends that the City Council consider the results of the Annual Pavement Rehabilitation FY 23 bid and award the bid to All American Asphalt; and
2. Authorize the City Manager to approve change orders up to ten percent of the contract

amount; and

3. Adopt the Notice to Exemption for this project.

**Exhibits:**

1. Bid Results
2. Bid Schedule Packet (Page A-12 and Pages C-4R through C-16)
3. Contractor's State of California and Department of Industrial relations License Detail
4. Notice of Exemption

City of Industry  
 Bid Results for Project ANNUAL PAVEMENT REHABILITATION FY 23 (CITY-1528)  
 Issued on 12/19/2024  
 Bid Due on April 03, 2025 10:00 AM (PDT)  
 Exported on 04/03/2025

Line Totals (Unit Price \* Quantity)

Item Num	Description	Unit of Measure	Qty	Sequel Contractors, Inc. - Unit Price	Sequel Contractors, Inc. - Line Total	Gentry Brothers, Inc. - Unit Price	Gentry Brothers, Inc. - Line Total
1	MOBILIZATION	LS	1	\$325,000.00	\$325,000.00	\$300,000.00	\$300,000.00
2	PREPARATION AND IMPLEMENTATION OF STORM WATER POLLUTION PREVENTION PLAN	LS	1	\$20,000.00	\$20,000.00	\$50,000.00	\$50,000.00
3	TRAFFIC CONTROL	LS	1	\$615,400.00	\$615,400.00	\$800,000.00	\$800,000.00
4	BONELLI STREET AERIALY DEPOSITED LEAD TESTING	LS	1	\$15,000.00	\$15,000.00	\$15,000.00	\$15,000.00
5	HAZARDOUS WASTE DISPOSAL	ALLOW	1	\$150,000.00	\$150,000.00	\$150,000.00	\$150,000.00
6	REMOVE AC PAVEMENT (BONELLI STREET)	SY	10500	\$9.00	\$94,500.00	\$6.00	\$63,000.00
7	COLD MILL EXISTING AC PAVEMENT, 2-1/2"	SY	84700	\$5.00	\$423,500.00	\$6.00	\$508,200.00
8	COLD MILL AC PAVEMENT 2-1/2" DEPTH BELOW LIP OF GUTTER, TAPERING TO 0 INCH DEPTH, DISTANCE PER PLAN FROM EDGE OFF PCC PAVEMENT/GUTTER	SY	19575	\$3.00	\$58,725.00	\$6.00	\$117,450.00
9	UNCLASSIFIED EXCAVATION (BONELLI STREET)	CY	4400	\$50.00	\$220,000.00	\$120.00	\$528,000.00
10	CONSTRUCT STREET PAVE-OUT PER CITY OF INDUSTRY STD PLAN NO. 111	SF	2100	\$45.00	\$94,500.00	\$4.00	\$8,400.00
11	SAWCUT AND REMOVE EXISTING SIDEWALK INCLUDING AGGREGATE BASE	SF	925	\$9.00	\$8,325.00	\$7.00	\$6,475.00
12	SAWCUT AND REMOVE EXISTING PCC CURB AND GUTTER INCLUDING AGGREGATE BASE	LF	420	\$30.00	\$12,600.00	\$20.00	\$8,400.00
13	SAWCUT AND REMOVE EXISTING PCC CURB AND GUTTER INCLUDING AGGREGATE BASE (BONELLI STREET)	LF	450	\$30.00	\$13,500.00	\$20.00	\$9,000.00
14	SAWCUT AND REMOVE EXISTING DRIVEWAY, INCLUDING AGGREGATE BASE	SF	6000	\$13.00	\$78,000.00	\$7.00	\$42,000.00
15	SAWCUT AND REMOVE EXISTING DRIVEWAY, INCLUDING AGGREGATE BASE (BONELLI STREET)	SF	6200	\$13.00	\$80,600.00	\$7.00	\$43,400.00
16	SAWCUT AND REMOVE PEDESTRIAN RAMP, INCLUDING AGGREGATE BASE	SF	4310	\$11.00	\$47,410.00	\$7.00	\$30,170.00
17	SAWCUT AND REMOVE PEDESTRIAN RAMP, INCLUDING AGGREGATE BASE (BONELLI STREET)	SF	420	\$11.00	\$4,620.00	\$7.00	\$2,940.00

Item Num	Description	Unit of Measure	Qty	Sequel Contractors, Inc. - Unit Price	Sequel Contractors, Inc. - Line Total	Gentry Brothers, Inc. - Unit Price	Gentry Brothers, Inc. - Line Total
18	ASPHALT CONCRETE PAVEMENT	TON	19950	\$128.00	\$2,553,600.00	\$103.00	\$2,054,850.00
19	CRUSHED AGGREGATE BASE	CY	4600	\$40.00	\$184,000.00	\$60.00	\$276,000.00
20	FURNISH AND INSTALL 3/8" ASPHALT RUBBER AND AGGREGATE MEMBRANE (ARAM)	SY	51640	\$4.50	\$232,380.00	\$6.00	\$309,840.00
21	Tensar InterAX NXP GEOGRID, OR APPROVED EQUAL	SY	10500	\$9.00	\$94,500.00	\$11.00	\$115,500.00
22	CONSTRUCT CONCRETE PAVEMENT TRANSITION PANEL PER CALTRANS STANDARD PLAN NO. P30.	SF	525	\$30.00	\$15,750.00	\$20.00	\$10,500.00
23	CONSTRUCT TYPE A2-8 PCC CURB AND GUTTER (W=2') PER CITY OF INDUSTRY STD. PLAN NO. 112	LF	930	\$60.00	\$55,800.00	\$80.00	\$74,400.00
24	CONSTRUCT PCC CURB AND GUTTER FOR DRIVEWAYS PER CITY OF INDUSTRY STD. PLAN NO. 114	LF	200	\$60.00	\$12,000.00	\$80.00	\$16,000.00
25	CONSTRUCT PEDESTRIAN RAMP, INCLUDING DETECTABLE WARNING SURFACE PER CALTRANS STANDARD PLAN NO. A88A, CASE PER PLAN	SF	5100	\$18.00	\$91,800.00	\$40.00	\$204,000.00
26	CONSTRUCT PCC DRIVEWAY PER DETAIL B, SHEET 2, INCLUDING ADJACENT CURB AND GUTTER	SF	12200	\$16.00	\$195,200.00	\$11.00	\$134,200.00
27	CONSTRUCT 4" PCC SIDEWALK PER CITY OF INDUSTRY STD. PLAN NO 115	SF	925	\$14.00	\$12,950.00	\$9.00	\$8,325.00
28	ADJUST MANHOLE COVER AND FRAME TO FINISHED GRADE	EA	77	\$1,300.00	\$100,100.00	\$800.00	\$61,600.00
29	ADJUST WATER OR GAS VALVE COVER AND FRAME TO FINISHED GRADE.	EA	74	\$600.00	\$44,400.00	\$125.00	\$9,250.00
30	RESTORE TRAFFIC LOOP DETECTORS	EA	33	\$700.00	\$23,100.00	\$525.00	\$17,325.00
31	REPAINT CURB RED	LF	33100	\$2.00	\$66,200.00	\$2.40	\$79,440.00
32	REPAINT RED CURB (BONELLI STREET)	LF	3200	\$2.00	\$6,400.00	\$2.40	\$7,680.00
33	REPAINT YELLOW CURB	LF	140	\$2.00	\$280.00	\$2.40	\$336.00
34	PAVEMENT MARKERS, MARKINGS AND TRAFFIC STRIPING	LS	1	\$225,000.00	\$225,000.00	\$300,000.00	\$300,000.00
35	RESTORE DRIVEWAY LOOP DETECTOR	EA	1	\$6,000.00	\$6,000.00	\$5,000.00	\$5,000.00
				Subtotal	\$6,181,140.00		\$6,366,681.00
				<b>Total</b>	<b>\$6,181,140.00</b>		<b>\$6,366,681.00</b>

City of Industry  
 Bid Results for Project ANNUAL PAVEMENT REHABILITATION FY 23 (CITY-1528)  
 Issued on 12/19/2024  
 Bid Due on April 03, 2025 10:00 AM (PDT)  
 Exported on 04/03/2025

Line Totals (Unit Price \* Quantity)

Item Num	Description	Unit of Measure	Qty	All American Asphalt - Unit Price	All American Asphalt - Line Total	Hardy & Harper, Inc - Unit Price	Hardy & Harper, Inc - Line Total
1	MOBILIZATION	LS	1	\$250,000.00	\$250,000.00	\$147,597.00	\$147,597.00
2	PREPARATION AND IMPLEMENTATION OF STORM WATER POLLUTION PREVENTION PLAN	LS	1	\$13,500.00	\$13,500.00	\$17,750.00	\$17,750.00
3	TRAFFIC CONTROL	LS	1	\$265,000.00	\$265,000.00	\$295,000.00	\$295,000.00
4	BONELLI STREET AERIALY DEPOSITED LEAD TESTING	LS	1	\$7,800.00	\$7,800.00	\$70,000.00	\$70,000.00
5	HAZARDOUS WASTE DISPOSAL	ALLOW	1	\$150,000.00	\$150,000.00	\$150,000.00	\$150,000.00
6	REMOVE AC PAVEMENT (BONELLI STREET)	SY	10500	\$19.00	\$199,500.00	\$7.00	\$73,500.00
7	COLD MILL EXISTING AC PAVEMENT, 2-1/2"	SY	84700	\$6.85	\$580,195.00	\$5.00	\$423,500.00
8	COLD MILL AC PAVEMENT 2-1/2" DEPTH BELOW LIP OF GUTTER, TAPERING TO 0 INCH DEPTH, DISTANCE PER PLAN FROM EDGE OFF PCC PAVEMENT/GUTTER	SY	19575	\$4.50	\$88,087.50	\$6.00	\$117,450.00
9	UNCLASSIFIED EXCAVATION (BONELLI STREET)	CY	4400	\$135.00	\$594,000.00	\$120.00	\$528,000.00
10	CONSTRUCT STREET PAVE-OUT PER CITY OF INDUSTRY STD PLAN NO. 111	SF	2100	\$32.00	\$67,200.00	\$36.00	\$75,600.00
11	SAWCUT AND REMOVE EXISTING SIDEWALK INCLUDING AGGREGATE BASE	SF	925	\$11.00	\$10,175.00	\$8.40	\$7,770.00
12	SAWCUT AND REMOVE EXISTING PCC CURB AND GUTTER INCLUDING AGGREGATE BASE	LF	420	\$32.00	\$13,440.00	\$50.00	\$21,000.00
13	SAWCUT AND REMOVE EXISTING PCC CURB AND GUTTER INCLUDING AGGREGATE BASE (BONELLI STREET)	LF	450	\$32.00	\$14,400.00	\$48.00	\$21,600.00
14	SAWCUT AND REMOVE EXISTING DRIVEWAY, INCLUDING AGGREGATE BASE	SF	6000	\$12.00	\$72,000.00	\$16.00	\$96,000.00
15	SAWCUT AND REMOVE EXISTING DRIVEWAY, INCLUDING AGGREGATE BASE (BONELLI STREET)	SF	6200	\$12.00	\$74,400.00	\$16.00	\$99,200.00
16	SAWCUT AND REMOVE PEDESTRIAN RAMP, INCLUDING AGGREGATE BASE	SF	4310	\$10.00	\$43,100.00	\$9.00	\$38,790.00
17	SAWCUT AND REMOVE PEDESTRIAN RAMP, INCLUDING AGGREGATE BASE (BONELLI STREET)	SF	420	\$10.00	\$4,200.00	\$8.00	\$3,360.00

Item Num	Description	Unit of Measure	Qty	All American Asphalt - Unit Price	All American Asphalt - Line Total	Hardy & Harper, Inc - Unit Price	Hardy & Harper, Inc - Line Total
18	ASPHALT CONCRETE PAVEMENT	TON	19950	\$128.00	\$2,553,600.00	\$135.00	\$2,693,250.00
19	CRUSHED AGGREGATE BASE	CY	4600	\$50.00	\$230,000.00	\$75.00	\$345,000.00
20	FURNISH AND INSTALL 3/8" ASPHALT RUBBER AND AGGREGATE MEMBRANE (ARAM)	SY	51640	\$5.00	\$258,200.00	\$5.10	\$263,364.00
21	Tensar InterAX NXP GEOGRID, OR APPROVED EQUAL	SY	10500	\$12.00	\$126,000.00	\$11.60	\$121,800.00
22	CONSTRUCT CONCRETE PAVEMENT TRANSITION PANEL PER CALTRANS STANDARD PLAN NO. P30.	SF	525	\$50.00	\$26,250.00	\$47.00	\$24,675.00
23	CONSTRUCT TYPE A2-8 PCC CURB AND GUTTER (W=2') PER CITY OF INDUSTRY STD. PLAN NO. 112	LF	930	\$70.00	\$65,100.00	\$115.00	\$106,950.00
24	CONSTRUCT PCC CURB AND GUTTER FOR DRIVEWAYS PER CITY OF INDUSTRY STD. PLAN NO. 114	LF	200	\$70.00	\$14,000.00	\$112.00	\$22,400.00
25	CONSTRUCT PEDESTRIAN RAMP, INCLUDING DETECTABLE WARNING SURFACE PER CALTRANS STANDARD PLAN NO. A88A, CASE PER PLAN	SF	5100	\$35.00	\$178,500.00	\$18.00	\$91,800.00
26	CONSTRUCT PCC DRIVEWAY PER DETAIL B, SHEET 2, INCLUDING ADJACENT CURB AND GUTTER	SF	12200	\$25.00	\$305,000.00	\$34.00	\$414,800.00
27	CONSTRUCT 4" PCC SIDEWALK PER CITY OF INDUSTRY STD. PLAN NO 115	SF	925	\$16.00	\$14,800.00	\$19.00	\$17,575.00
28	ADJUST MANHOLE COVER AND FRAME TO FINISHED GRADE	EA	77	\$1,400.00	\$107,800.00	\$1,285.00	\$98,945.00
29	ADJUST WATER OR GAS VALVE COVER AND FRAME TO FINISHED GRADE.	EA	74	\$600.00	\$44,400.00	\$1,286.00	\$95,164.00
30	RESTORE TRAFFIC LOOP DETECTORS	EA	33	\$495.00	\$16,335.00	\$500.00	\$16,500.00
31	REPAINT CURB RED	LF	33100	\$2.00	\$66,200.00	\$1.00	\$33,100.00
32	REPAINT RED CURB (BONELLI STREET)	LF	3200	\$2.00	\$6,400.00	\$1.00	\$3,200.00
33	REPAINT YELLOW CURB	LF	140	\$2.00	\$280.00	\$1.00	\$140.00
34	PAVEMENT MARKERS, MARKINGS AND TRAFFIC STRIPING	LS	1	\$120,000.00	\$120,000.00	\$111,720.00	\$111,720.00
35	RESTORE DRIVEWAY LOOP DETECTOR	EA	1	\$495.00	\$495.00	\$500.00	\$500.00
					\$6,580,357.50		\$6,647,000.00
					<b>\$6,580,357.50</b>		<b>\$6,647,000.00</b>

City of Industry  
 Bid Results for Project ANNUAL PAVEMENT REHABILITATION FY 23 (CITY-1528)  
 Issued on 12/19/2024  
 Bid Due on April 03, 2025 10:00 AM (PDT)  
 Exported on 04/03/2025

Line Totals (Unit Price \* Quantity)

Item Num	Description	Unit of Measure	Qty	SULLY-MILLER CONTRACTING COMPANY - Unit Price	SULLY-MILLER CONTRACTING COMPANY - Line Total	PALP dba Excel Paving Company - Unit Price	PALP dba Excel Paving Company - Line Total
1	MOBILIZATION	LS	1	\$334,211.30	\$334,211.30	\$698,000.00	\$698,000.00
2	PREPARATION AND IMPLEMENTATION OF STORM WATER POLLUTION PREVENTION PLAN	LS	1	\$35,000.00	\$35,000.00	\$25,000.00	\$25,000.00
3	TRAFFIC CONTROL	LS	1	\$635,000.00	\$635,000.00	\$236,000.00	\$236,000.00
4	BONELLI STREET AERIALY DEPOSITED LEAD TESTING	LS	1	\$20,000.00	\$20,000.00	\$9,000.00	\$9,000.00
5	HAZARDOUS WASTE DISPOSAL	ALLOW	1	\$150,000.00	\$150,000.00	\$150,000.00	\$150,000.00
6	REMOVE AC PAVEMENT (BONELLI STREET)	SY	10500	\$16.50	\$173,250.00	\$30.00	\$315,000.00
7	COLD MILL EXISTING AC PAVEMENT, 2-1/2"	SY	84700	\$6.30	\$533,610.00	\$6.00	\$508,200.00
8	COLD MILL AC PAVEMENT 2-1/2" DEPTH BELOW LIP OF GUTTER, TAPERING TO 0 INCH DEPTH, DISTANCE PER PLAN FROM EDGE OFF PCC PAVEMENT/GUTTER	SY	19575	\$3.50	\$68,512.50	\$3.00	\$58,725.00
9	UNCLASSIFIED EXCAVATION (BONELLI STREET)	CY	4400	\$74.00	\$325,600.00	\$149.00	\$655,600.00
10	CONSTRUCT STREET PAVE-OUT PER CITY OF INDUSTRY STD PLAN NO. 111	SF	2100	\$27.00	\$56,700.00	\$39.00	\$81,900.00
11	SAWCUT AND REMOVE EXISTING SIDEWALK INCLUDING AGGREGATE BASE	SF	925	\$13.00	\$12,025.00	\$8.00	\$7,400.00
12	SAWCUT AND REMOVE EXISTING PCC CURB AND GUTTER INCLUDING AGGREGATE BASE	LF	420	\$71.00	\$29,820.00	\$31.00	\$13,020.00
13	SAWCUT AND REMOVE EXISTING PCC CURB AND GUTTER INCLUDING AGGREGATE BASE (BONELLI STREET)	LF	450	\$67.00	\$30,150.00	\$39.00	\$17,550.00
14	SAWCUT AND REMOVE EXISTING DRIVEWAY, INCLUDING AGGREGATE BASE	SF	6000	\$21.00	\$126,000.00	\$15.00	\$90,000.00
15	SAWCUT AND REMOVE EXISTING DRIVEWAY, INCLUDING AGGREGATE BASE (BONELLI STREET)	SF	6200	\$21.00	\$130,200.00	\$16.00	\$99,200.00
16	SAWCUT AND REMOVE PEDESTRIAN RAMP, INCLUDING AGGREGATE BASE	SF	4310	\$14.00	\$60,340.00	\$10.00	\$43,100.00
17	SAWCUT AND REMOVE PEDESTRIAN RAMP, INCLUDING AGGREGATE BASE (BONELLI STREET)	SF	420	\$14.00	\$5,880.00	\$11.00	\$4,620.00

Item Num	Description	Unit of Measure	Qty	SULLY-MILLER CONTRACTING COMPANY - Unit Price	SULLY-MILLER CONTRACTING COMPANY - Line Total	PALP dba Excel Paving Company - Unit Price	PALP dba Excel Paving Company - Line Total
18	ASPHALT CONCRETE PAVEMENT	TON	19950	\$125.00	\$2,493,750.00	\$118.00	\$2,354,100.00
19	CRUSHED AGGREGATE BASE	CY	4600	\$67.00	\$308,200.00	\$100.00	\$460,000.00
20	FURNISH AND INSTALL 3/8" ASPHALT RUBBER AND AGGREGATE MEMBRANE (ARAM)	SY	51640	\$5.00	\$258,200.00	\$6.00	\$309,840.00
21	Tensar InterAX NXP GEOGRID, OR APPROVED EQUAL	SY	10500	\$11.00	\$115,500.00	\$8.00	\$84,000.00
22	CONSTRUCT CONCRETE PAVEMENT TRANSITION PANEL PER CALTRANS STANDARD PLAN NO. P30.	SF	525	\$16.00	\$8,400.00	\$81.00	\$42,525.00
23	CONSTRUCT TYPE A2-8 PCC CURB AND GUTTER (W=2') PER CITY OF INDUSTRY STD. PLAN NO. 112	LF	930	\$88.00	\$81,840.00	\$86.00	\$79,980.00
24	CONSTRUCT PCC CURB AND GUTTER FOR DRIVEWAYS PER CITY OF INDUSTRY STD. PLAN NO. 114	LF	200	\$88.00	\$17,600.00	\$87.00	\$17,400.00
25	CONSTRUCT PEDESTRIAN RAMP, INCLUDING DETECTABLE WARNING SURFACE PER CALTRANS STANDARD PLAN NO. A88A, CASE PER PLAN	SF	5100	\$29.00	\$147,900.00	\$30.00	\$153,000.00
26	CONSTRUCT PCC DRIVEWAY PER DETAIL B, SHEET 2, INCLUDING ADJACENT CURB AND GUTTER	SF	12200	\$26.00	\$317,200.00	\$29.00	\$353,800.00
27	CONSTRUCT 4" PCC SIDEWALK PER CITY OF INDUSTRY STD. PLAN NO 115	SF	925	\$22.00	\$20,350.00	\$18.00	\$16,650.00
28	ADJUST MANHOLE COVER AND FRAME TO FINISHED GRADE	EA	77	\$1,550.00	\$119,350.00	\$1,400.00	\$107,800.00
29	ADJUST WATER OR GAS VALVE COVER AND FRAME TO FINISHED GRADE.	EA	74	\$1,050.00	\$77,700.00	\$800.00	\$59,200.00
30	RESTORE TRAFFIC LOOP DETECTORS	EA	33	\$475.00	\$15,675.00	\$490.00	\$16,170.00
31	REPAINT CURB RED	LF	33100	\$1.92	\$63,552.00	\$3.00	\$99,300.00
32	REPAINT RED CURB (BONELLI STREET)	LF	3200	\$1.92	\$6,144.00	\$3.00	\$9,600.00
33	REPAINT YELLOW CURB	LF	140	\$1.92	\$268.80	\$3.00	\$420.00
34	PAVEMENT MARKERS, MARKINGS AND TRAFFIC STRIPING	LS	1	\$114,995.00	\$114,995.00	\$112,000.00	\$112,000.00
35	RESTORE DRIVEWAY LOOP DETECTOR	EA	1	\$475.00	\$475.00	\$490.00	\$490.00
					\$6,893,398.60		\$7,288,590.00
					<b>\$6,893,398.60</b>		<b>\$7,288,590.00</b>

City of Industry

Bid Results for Project ANNUAL PAVEMENT REHABILITATION FY 23 (CITY-1528)

Issued on 12/19/2024

Bid Due on April 03, 2025 10:00 AM (PDT)

Exported on 04/03/2025

Line Totals (Unit Price \* Quantity)

Item Num	Description	Unit of Measure	Qty	Toro Enterprises, Inc. - Unit Price	Toro Enterprises, Inc. - Line Total
1	MOBILIZATION	LS	1	\$482,000.00	\$482,000.00
2	PREPARATION AND IMPLEMENTATION OF STORM WATER POLLUTION PREVENTION PLAN	LS	1	\$55,000.00	\$55,000.00
3	TRAFFIC CONTROL	LS	1	\$650,000.00	\$650,000.00
4	BONELLI STREET AERIALY DEPOSITED LEAD TESTING	LS	1	\$55,000.00	\$55,000.00
5	HAZARDOUS WASTE DISPOSAL	ALLOW	1	\$150,000.00	\$150,000.00
6	REMOVE AC PAVEMENT (BONELLI STREET)	SY	10500	\$11.50	\$120,750.00
7	COLD MILL EXISTING AC PAVEMENT, 2-1/2"	SY	84700	\$6.85	\$580,195.00
8	COLD MILL AC PAVEMENT 2-1/2" DEPTH BELOW LIP OF GUTTER, TAPERING TO 0 INCH DEPTH, DISTANCE PER PLAN FROM EDGE OFF PCC PAVEMENT/GUTTER	SY	19575	\$4.60	\$90,045.00
9	UNCLASSIFIED EXCAVATION (BONELLI STREET)	CY	4400	\$90.00	\$396,000.00
10	CONSTRUCT STREET PAVE-OUT PER CITY OF INDUSTRY STD PLAN NO. 111	SF	2100	\$38.00	\$79,800.00
11	SAWCUT AND REMOVE EXISTING SIDEWALK INCLUDING AGGREGATE BASE	SF	925	\$6.50	\$6,012.50
12	SAWCUT AND REMOVE EXISTING PCC CURB AND GUTTER INCLUDING AGGREGATE BASE	LF	420	\$44.00	\$18,480.00
13	SAWCUT AND REMOVE EXISTING PCC CURB AND GUTTER INCLUDING AGGREGATE BASE (BONELLI STREET)	LF	450	\$45.00	\$20,250.00
14	SAWCUT AND REMOVE EXISTING DRIVEWAY, INCLUDING AGGREGATE BASE	SF	6000	\$10.50	\$63,000.00
15	SAWCUT AND REMOVE EXISTING DRIVEWAY, INCLUDING AGGREGATE BASE (BONELLI STREET)	SF	6200	\$10.85	\$67,270.00
16	SAWCUT AND REMOVE PEDESTRIAN RAMP, INCLUDING AGGREGATE BASE	SF	4310	\$7.00	\$30,170.00
17	SAWCUT AND REMOVE PEDESTRIAN RAMP, INCLUDING AGGREGATE BASE (BONELLI STREET)	SF	420	\$13.00	\$5,460.00

Item Num	Description	Unit of Measure	Qty	Toro Enterprises, Inc. - Unit Price	Toro Enterprises, Inc. - Line Total
18	ASPHALT CONCRETE PAVEMENT	TON	19950	\$140.00	\$2,793,000.00
19	CRUSHED AGGREGATE BASE	CY	4600	\$95.50	\$439,300.00
20	FURNISH AND INSTALL 3/8" ASPHALT RUBBER AND AGGREGATE MEMBRANE (ARAM)	SY	51640	\$4.90	\$253,036.00
21	Tensar InterAX NXP GEOGRID, OR APPROVED EQUAL	SY	10500	\$12.00	\$126,000.00
22	CONSTRUCT CONCRETE PAVEMENT TRANSITION PANEL PER CALTRANS STANDARD PLAN NO. P30.	SF	525	\$75.00	\$39,375.00
23	CONSTRUCT TYPE A2-8 PCC CURB AND GUTTER (W=2') PER CITY OF INDUSTRY STD. PLAN NO. 112	LF	930	\$113.00	\$105,090.00
24	CONSTRUCT PCC CURB AND GUTTER FOR DRIVEWAYS PER CITY OF INDUSTRY STD. PLAN NO. 114	LF	200	\$115.00	\$23,000.00
25	CONSTRUCT PEDESTRIAN RAMP, INCLUDING DETECTABLE WARNING SURFACE PER CALTRANS STANDARD PLAN NO. A88A, CASE PER PLAN	SF	5100	\$33.00	\$168,300.00
26	CONSTRUCT PCC DRIVEWAY PER DETAIL B, SHEET 2, INCLUDING ADJACENT CURB AND GUTTER	SF	12200	\$31.00	\$378,200.00
27	CONSTRUCT 4" PCC SIDEWALK PER CITY OF INDUSTRY STD. PLAN NO 115	SF	925	\$27.50	\$25,437.50
28	ADJUST MANHOLE COVER AND FRAME TO FINISHED GRADE	EA	77	\$1,550.00	\$119,350.00
29	ADJUST WATER OR GAS VALVE COVER AND FRAME TO FINISHED GRADE.	EA	74	\$510.00	\$37,740.00
30	RESTORE TRAFFIC LOOP DETECTORS	EA	33	\$520.00	\$17,160.00
31	REPAINT CURB RED	LF	33100	\$1.80	\$59,580.00
32	REPAINT RED CURB (BONELLI STREET)	LF	3200	\$1.90	\$6,080.00
33	REPAINT YELLOW CURB	LF	140	\$1.80	\$252.00
34	PAVEMENT MARKERS, MARKINGS AND TRAFFIC STRIPING	LS	1	\$156,000.00	\$156,000.00
35	RESTORE DRIVEWAY LOOP DETECTOR	EA	1	\$525.00	\$525.00
					\$7,616,858.00
					<b>\$7,616,858.00</b>

**BID BOND**

PROJECT NO. 528  
ANNUAL PAVEMENT REHABILITATION FY 23  
CONTRACT NO. CITY-1528

KNOW ALL MEN BY THESE PRESENTS that we All American Asphalt  
Fidelity and Deposit Company of Maryland as BIDDER, and \_\_\_\_\_  
\_\_\_\_\_ a corporation organized  
and existing under the laws of the State of Illinois, and duly authorized to transact  
business under the laws of the State of California, as SURETY, are held and firmly bound unto  
the City of Industry ("CITY"), in the penal sum of Ten Percent of Total Amount Bid----- [IN WORDS]  
dollars (\$ 10% of Bid), which is 10 percent of the total amount bid by BIDDER to CITY for  
the above-stated project, for the payment of which sum, BIDDER and SURETY agree to be bound,  
jointly and severally, firmly by these presents.

THE CONDITIONS OF THIS OBLIGATION ARE SUCH that, whereas BIDDER is about to submit  
a bid to CITY for the above-stated project, if said bid is rejected, or if said bid is accepted and a  
contract is awarded and entered into by BIDDER in the manner and time specified, then this  
obligation shall be null and void, otherwise it shall remain in full force and effect in favor of CITY.

IN WITNESS WHEREOF the parties hereto have set their names, titles, hands, and seals this  
18th day of March, 2025

**BIDDER:**

Name: All American Asphalt

Address: 400 East Sixth Street

Corona, CA 92879

By: Edward J Carson

Signature: \_\_\_\_\_

Title: Vice President

**SURETY:**

Name: Fidelity and Deposit Company of Maryland

Address: 777 S. Figueroa Street, Suite 3900

Los Angeles, CA 90017

By: Rebecca Haas-Bates

Signature: Rebecca Haas-Bates

Title: Attorney-in-Fact



**Note:**

- The signature on this form (Bid Bond, Page A-12) must be acknowledged before a Notary Public with an Acknowledgement Form attached.
- If any person is signing as attorney-in-fact, evidence of the authority for that must be attached as well.

**CALIFORNIA ALL-PURPOSE ACKNOWLEDGEMENT**

**CIVIL CODE § 1189**

A notary public or other officer completing this certificate verifies only the identity of the individual who signed the document to which this certificate is attached, and not the truthfulness, accuracy, or validity of that document.

State of California

County of Riverside

On 03/20/2025 before me, Kathryn Marconi, Notary Public  
Date Here Insert name and Title of the Officer

personally appeared Edward J. Carlson  
Name(s) of Signer(s)

who proved to me on the basis of satisfactory evidence to be the person(s) whose name(s) is/are subscribed to the within instrument and acknowledged to me that he/she/they executed the same in his/her/their authorized capacity(ies), and that by his/her/their signature(s) on the instrument the person(s), or the entity upon behalf of which the person(s) acted, executed the instrument.

I certify under PENALTY OF PERJURY under the laws of the State of California that the forgoing paragraph is true and correct.

WITNESS my hand and official seal.



Place Notary Seal Above

Signature Kathryn Marconi  
Signature of Notary Public

**OPTIONAL**

Though the information below is not required by law, it may prove valuable to person relying on the document and could prevent fraudulent removal and reattachment of this form to another document.

**Description of Attached Document**

Title or Type of Document Bid Bond

Document Date: 03/18/2025 Number of Pages: One (1)

Signer(s) Other Than Named Above: Rebecca Haas-Bates (Attorney in Fact)

**Capacity(ies) Claimed by Signer(s)**

Signer's Name: Edward J. Carlson

- Individual
- Corporate Officer — Title(s): Vice President
- Partner  Limited  General
- Attorney in Fact
- Trustee
- Other: \_\_\_\_\_

Signer is Representing:  
All American Asphalt

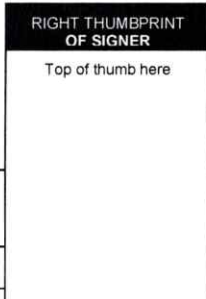

Signer's Name: \_\_\_\_\_

- Individual
- Corporate Officer — Title(s): \_\_\_\_\_
- Partner  Limited  General
- Attorney in Fact
- Trustee
- Other: \_\_\_\_\_

Signer is Representing: \_\_\_\_\_

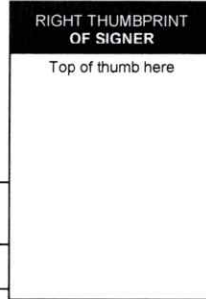

**CALIFORNIA ALL-PURPOSE ACKNOWLEDGMENT**

**CIVIL CODE § 1189**

A notary public or other officer completing this certificate verifies only the identity of the individual who signed the document to which this certificate is attached, and not the truthfulness, accuracy, or validity of that document.

State of California )

County of Orange )

On 03/18/2025 before me, L. Gomez, Notary Public

*Date Here Insert Name and Title of the Officer*

personally appeared Rebecca Haas-Bates

*Name(s) of Signer(s)*

who proved to me on the basis of satisfactory evidence to be the person(s) whose name(s) is/are subscribed to the within instrument and acknowledged to me that he/she/they executed the same in his/her/their authorized capacity(ies), and that by his/her/their signature(s) on the instrument the person(s), or the entity upon behalf of which the person(s) acted, executed the instrument.

I certify under PENALTY OF PERJURY under the laws of the State of California that the foregoing paragraph is true and correct.

WITNESS my hand and official seal.

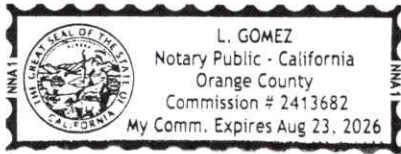

Signature *L. Gomez*  
*Signature of Notary Public*

*Place Notary Seal Above*

**OPTIONAL**

*Though this section is optional, completing this information can deter alteration of the document or fraudulent reattachment of this form to an unintended document.*

**Description of Attached Document**

Title or Type of Document: Bid Bond Document Date: 03/18/2025

Number of Pages: One(1) Signer(s) Other Than Named Above: All American Asphalt

**Capacity(ies) Claimed by Signer(s)**

Signer's Name: Rebecca Haas-Bates

Corporate Officer — Title(s): \_\_\_\_\_

Partner —  Limited  General

Individual  Attorney in Fact

Trustee  Guardian or Conservator

Other: \_\_\_\_\_

Signer Is Representing: \_\_\_\_\_

Fidelity and Deposit Company of Maryland

Signer's Name: \_\_\_\_\_

Corporate Officer — Title(s): \_\_\_\_\_

Partner —  Limited  General

Individual  Attorney in Fact

Trustee  Guardian or Conservator

Other: \_\_\_\_\_

Signer Is Representing: \_\_\_\_\_

**EXTRACT FROM BY-LAWS OF THE COMPANIES**

"Article V, Section 8. Attorneys-in-Fact. The Chief Executive Officer, the President, or any Executive Vice President or Vice President may, by written instrument under the attested corporate seal, appoint attorneys-in-fact with authority to execute bonds, policies, recognizances, stipulations, undertakings, or other like instruments on behalf of the Company, and may authorize any officer or any such attorney-in-fact to affix the corporate seal thereto; and may with or without cause modify or revoke any such appointment or authority at any time."

**CERTIFICATE**

I, the undersigned, Vice President of the ZURICH AMERICAN INSURANCE COMPANY, the COLONIAL AMERICAN CASUALTY AND SURETY COMPANY, and the FIDELITY AND DEPOSIT COMPANY OF MARYLAND, do hereby certify that the foregoing Power of Attorney is still in full force and effect on the date of this certificate; and I do further certify that Article V, Section 8, of the By-Laws of the Companies is still in force.

This Power of Attorney and Certificate may be signed by facsimile under and by authority of the following resolution of the Board of Directors of the ZURICH AMERICAN INSURANCE COMPANY at a meeting duly called and held on the 15th day of December 1998.

RESOLVED: "That the signature of the President or a Vice President and the attesting signature of a Secretary or an Assistant Secretary and the Seal of the Company may be affixed by facsimile on any Power of Attorney...Any such Power or any certificate thereof bearing such facsimile signature and seal shall be valid and binding on the Company."

This Power of Attorney and Certificate may be signed by facsimile under and by authority of the following resolution of the Board of Directors of the COLONIAL AMERICAN CASUALTY AND SURETY COMPANY at a meeting duly called and held on the 5th day of May, 1994, and the following resolution of the Board of Directors of the FIDELITY AND DEPOSIT COMPANY OF MARYLAND at a meeting duly called and held on the 10th day of May, 1990.

RESOLVED: "That the facsimile or mechanically reproduced seal of the company and facsimile or mechanically reproduced signature of any Vice-President, Secretary, or Assistant Secretary of the Company, whether made heretofore or hereafter, wherever appearing upon a certified copy of any power of attorney issued by the Company, shall be valid and binding upon the Company with the same force and effect as though manually affixed.

IN TESTIMONY WHEREOF, I have hereunto subscribed my name and affixed the corporate seals of the said Companies, this 18th day of March, 2025.



*MJ Pethick*

Mary Jean Pethick  
Vice President

**TO REPORT A CLAIM WITH REGARD TO A SURETY BOND, PLEASE SUBMIT A COMPLETE DESCRIPTION OF THE CLAIM INCLUDING THE PRINCIPAL ON THE BOND, THE BOND NUMBER, AND YOUR CONTACT INFORMATION TO:**

Zurich Surety Claims  
1299 Zurich Way  
Schaumburg, IL 60196-1056  
[reportsfclaims@zurichna.com](mailto:reportsfclaims@zurichna.com)  
800-626-4577

**Authenticity of this bond can be confirmed at [bondvalidator.zurichna.com](http://bondvalidator.zurichna.com) or 410-559-8790**

**ZURICH AMERICAN INSURANCE COMPANY  
COLONIAL AMERICAN CASUALTY AND SURETY COMPANY  
FIDELITY AND DEPOSIT COMPANY OF MARYLAND  
POWER OF ATTORNEY**

KNOW ALL MEN BY THESE PRESENTS: That the ZURICH AMERICAN INSURANCE COMPANY, a corporation of the State of New York, the COLONIAL AMERICAN CASUALTY AND SURETY COMPANY, a corporation of the State of Illinois, and the FIDELITY AND DEPOSIT COMPANY OF MARYLAND a corporation of the State of Illinois (herein collectively called the "Companies"), by Christopher Nolan, Vice President, in pursuance of authority granted by Article V, Section 8, of the By-Laws of said Companies, which are set forth on the reverse side hereof and are hereby certified to be in full force and effect on the date hereof, do hereby nominate, constitute, and appoint **William SYRKIN, Richard ADAIR, Rebecca HAAS-BATES of Irvine, California,** its true and lawful agent and Attorney-in-Fact, to make, execute, seal and deliver, for, and on its behalf as surety, and as its act and deed: **any and all bonds and undertakings,** and the execution of such bonds or undertakings in pursuance of these presents, shall be as binding upon said Companies, as fully and amply, to all intents and purposes, as if they had been duly executed and acknowledged by the regularly elected officers of the ZURICH AMERICAN INSURANCE COMPANY at its office in New York, New York., the regularly elected officers of the COLONIAL AMERICAN CASUALTY AND SURETY COMPANY at its office in Owings Mills, Maryland., and the regularly elected officers of the FIDELITY AND DEPOSIT COMPANY OF MARYLAND at its office in Owings Mills, Maryland., in their own proper persons.

The said Vice President does hereby certify that the extract set forth on the reverse side hereof is a true copy of Article V, Section 8, of the By-Laws of said Companies. and is now in force.

IN WITNESS WHEREOF, the said Vice-President has hereunto subscribed his/her names and affixed the Corporate Seals of the said **ZURICH AMERICAN INSURANCE COMPANY, COLONIAL AMERICAN CASUALTY AND SURETY COMPANY, and FIDELITY AND DEPOSIT COMPANY OF MARYLAND,** this 7th day of January A.D. 2025.

**ATTEST:  
ZURICH AMERICAN INSURANCE COMPANY  
COLONIAL AMERICAN CASUALTY AND SURETY COMPANY  
FIDELITY AND DEPOSIT COMPANY OF MARYLAND**



By: Christopher Nolan  
Vice President

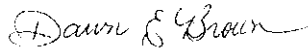

By: Dawn E. Brown  
Secretary



**State of Maryland  
County of Baltimore**

On this 7th day of January A.D. 2025, before the subscriber, a Notary Public of the State of Maryland, duly commissioned and qualified, **Christopher Nolan, Vice President and Dawn E. Brown, Secretary** of the Companies, to me personally known to be the individuals and officers described in and who executed the preceding instrument, and acknowledged the execution of same, and being by me duly sworn, depose and saith, that he/she is the said officer of the Company aforesaid, and that the seals affixed to the preceding instrument are the Corporate Seals of said Companies, and that the said Corporate Seals and the signature as such officer were duly affixed and subscribed to the said instrument by the authority and direction of the said Corporations.

IN TESTIMONY WHEREOF, I have hereunto set my hand and affixed my Official Seal the day and year first above written.

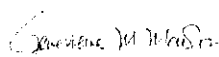

Genevieve M. Maison  
Notary Public  
My Commission Expire January 27, 2029



**Authenticity of this bond can be confirmed at [bondvalidator.zurichna.com](http://bondvalidator.zurichna.com) or 410-559-8790**

**SHADING INDICATES  
CHANGES MADE IN  
ADDENDUM NO. 5**

**PLEASE NOTE THAT UNIT  
PRICES SHALL ONLY BE  
ENTERED ONLINE WITHIN THE  
PLANETBIDS™ SOFTWARE. BID  
SCHEDULE PAGES C-4  
THROUGH C-12 ARE REQUIRED  
TO BE SUBMITTED AS A PDF  
UPLOAD VIA PLANETBIDS PER  
CHECKLIST ON PAGE B-6.**

**SECTION C  
BID SCHEDULE**

**FOR  
CITY OF INDUSTRY  
PROJECT NO. 528**

**ANNUAL PAVEMENT REHABILITATION FY 23**

**CONTRACT NO. CITY-1528**

**BIDDER: All American Asphalt**

Hereby proposes to construct the above-named project in accordance with the plans and specifications for the following prices:

**SCHEDULE OF WORK ITEMS**

<b>NO.</b>	<b>DESCRIPTION</b>	<b>APPROX. QTY</b>	<b>UNIT MEAS.</b>	<b>UNIT PRICE</b>	<b>TOTAL</b>
1.	MOBILIZATION	1	LS		
2.	PREPRATION AND IMPLEMENTATION OF STORM WATER POLLUTION PREVENTION PLAN	1	LS		
3.	TRAFFIC CONTROL	1	LS		
4.	BONELLI STREET AERIALY DEPOSITED LEAD TESTING	1	LS		
5.	HAZARDOUS WASTE DISPOSAL	1	ALLOW	\$150,000	\$150,000
6.	REMOVE AC PAVEMENT (BONELLI STREET)	10,500	SY		
7.	COLD MILL EXISTING AC PAVEMENT, 2-1/2"	84,700	SY		
8.	COLD MILL AC PAVEMENT 2-1/2" DEPTH BELOW LIP OF GUTTER, TAPERING TO 0 INCH DEPTH, DISTANCE PER PLAN FROM EDGE OFF PCC PAVEMENT/GUTTER	19,575	SY		
9.	UNCLASSIFIED EXCAVATION (BONELLI STREET)	4,400	CY		
10.	CONSTRUCT STREET PAVE-OUT PER CITY OF INDUSTRY STD PLAN NO. 111	2,100	SF		
11.	SAWCUT AND REMOVE EXISTING SIDEWALK INCLUDING AGGREGATE BASE	925	SF		
12.	SAWCUT AND REMOVE EXISTING PCC CURB AND GUTTER INCLUDING AGGREGATE BASE	420	LF		

**C-4R**

**SHADING INDICATES  
CHANGES MADE IN  
ADDENDUM NO. 5**

NO.	DESCRIPTION	APPROX. QTY	UNIT MEAS.	UNIT PRICE	TOTAL
13.	SAWCUT AND REMOVE EXISTING PCC CURB AND GUTTER INCLUDING AGGREGATE BASE (BONELLI STREET)	450	LF		
14.	SAWCUT AND REMOVE EXISTING DRIVEWAY, INCLUDING AGGREGATE BASE	6,000	SF		
15.	SAWCUT AND REMOVE EXISTING DRIVEWAY, INCLUDING AGGREGATE BASE (BONELLI STREET)	6,200	SF		
16.	SAWCUT AND REMOVE PEDESTRIAN RAMP, INCLUDING AGGREGATE BASE	4,310	SF		
17.	SAWCUT AND REMOVE PEDESTRIAN RAMP, INCLUDING AGGREGATE BASE (BONELLI STREET)	420	SF		
18.	ASPHALT CONCRETE PAVEMENT	19,950	TON		
19.	CRUSHED AGGREGATE BASE	4,600	CY		
20.	FURNISH AND INSTALL 3/8" ASPHALT RUBBER AND AGGREGATE MEMBRANE (ARAM)	51,640	SY		
21.	Tensar InterAX NXP GEOGRID, OR APPROVED EQUAL	10,500	SY		
22.	CONSTRUCT CONCRETE PAVEMENT TRANSITION PANEL PER CALTRANS STANDARD PLAN NO. P30.	525	SF		
23.	CONSTRUCT TYPE A2-8 PCC CURB AND GUTTER (W=2') PER CITY OF INDUSTRY STD. PLAN NO. 112	930	LF		
24.	CONSTRUCT PCC CURB AND GUTTER FOR DRIVEWAYS PER CITY OF INDUSTRY STD. PLAN NO. 114	200	LF		
25.	CONSTRUCT PEDESTRIAN RAMP, INCLUDING DETECTABLE WARNING SURFACE PER CALTRANS STANDARD PLAN NO. A88A, CASE PER PLAN	5,100	SF		
26.	CONSTRUCT PCC DRIVEWAY PER DETAIL B, SHEET 2, INCLUDING ADJACENT CURB AND GUTTER	12,200	SF		
27.	CONSTRUCT 4" PCC SIDEWALK PER CITY OF INDUSTRY STD. PLAN NO 115	925	SF		
28.	ADJUST MANHOLE COVER AND FRAME TO FINISHED GRADE	77	EA		
29.	ADJUST WATER OR GAS VALVE COVER AND FRAME TO FINISHED GRADE.	74	EA		
30.	RESTORE TRAFFIC LOOP DETECTORS	33	EA		
31.	REPAINT CURB RED	33,100	LF		
32.	REPAINT RED CURB (BONELLI STREET)	3,200	LF		
33.	REPAINT YELLOW CURB	140	LF		

C-5R

**SHADING INDICATES  
CHANGES MADE IN  
ADDENDUM NO. 5**

NO.	DESCRIPTION	APPROX. QTY	UNIT MEAS.	UNIT PRICE	TOTAL
34.	PAVEMENT MARKERS, MARKINGS AND TRAFFIC STRIPING	1	LS		
35.	RESTORE DRIVEWAY LOOP DETECTOR	1	EA		
				GRAND TOTAL	

I hereby certify that on 3/17, 2025, Edward J Carlson, VP  
(Print Name)  
 examined the site of the proposed work, and the undersigned, fully understands the scope of work and has checked carefully all words and figures inserted in the Bid Schedule.

By:

All American Asphalt  
 CONTRACTOR NAME  
publicworks@allamericanasphalt.com  
 EMAIL ADDRESS  
1000001051  
 DIR #  
Edward J Carlson, Vice President  
 PRINT NAME  
  
 SIGNATURE

C-6R

**BID RESULTS**

CITY OF INDUSTRY  
PROJECT NO. 528

ANNUAL PAVEMENT REHABILITATION FY 23

CONTRACT NO. CITY-1528

**PLEASE NOTE:** This page was intentionally left blank. After the bid has been awarded, it will be replaced with the awardee's Bid Results from PlanetBids™

## BIDDER'S INFORMATION SHEET

- **Receipt of any addenda shall be acknowledged only online through the PlanetBids™ software.**

RETENTION MONEY OPTION: Please initial one of the following options.

  
(Initials)

1. I will provide securities (escrow account) in lieu of monies to be withheld to ensure performance under the contract as per Section D63, General Provisions.

  
(Initials)

2. I will not provide securities in lieu of monies to ensure performance under the contract. I understand retention will be held by the City of Industry per Section D22, General Provisions.

The undersigned, as bidder, declares as follows:

1. The only persons or parties interested in this proposal as principals are those named herein;
2. This proposal is made without collusion with any other person, firm or corporation;
3. We have carefully examined the location of the proposed work, the attached proposed form of contract, and the plans therein referred to; and
4. We propose and agree, if this Proposal is accepted, that we will contract with the City of Industry in the form of the copy of the contract attached hereto;
5. We will provide all necessary machinery, tools, apparatus and other means of construction and/or maintenance;
6. We will do all the work and furnish all the materials specified in the contract, in the manner and time therein prescribed, and according to the requirements of the CITY Engineer as therein set forth; and
7. This bid is sufficient to allow us to comply with all applicable local, state, and federal laws or regulations governing the labor or services to be provided; and
8. We will take in full payment therefore in the amounts shown on the Bid Schedule.

IN WITNESS WHEREOF, Bidder executes and submits this proposal with the names, titles, hands, and seals of all aforementioned principals this 14 day of January, 2025.

The undersigned declares under penalty of perjury under the laws of the State of California that the representations made hereto are true and correct.

All American Asphalt  
Bidder

400 East Sixth Street  
Mailing Address

Corona, CA 92879  
City/State/Zip

( 951)736-7600  
Telephone

( 951)-736-7646  
Fax

  
Signature

Edward J Carlson  
Print Name

Vice President  
Title

267073 A,C-12  
License No./Class

1/31/26  
Expiration Date

Select **one** of the following: The Bidder is a:

Partnership

Corporation

Individual

The names of all persons, firms or corporations interested in this bid are: (See Section B, Page B-2, Item 4 - Signature of Bid).

**AFFIX CORPORATE SEAL**

Mark Luer, President

Edward J Carlson, Vice President

Michael Farkas, Secretary

**Note:**

- The signature on this form (Bidders Information Sheet, Pages C-8 and C-9) must be acknowledged before a Notary Public with an Acknowledgement Form attached.
- If any person is signing as attorney-in-fact, evidence of the authority for that must be attached as well.

**CALIFORNIA ALL-PURPOSE ACKNOWLEDGEMENT**

**CIVIL CODE § 1189**

A notary public or other officer completing this certificate verifies only the identity of the individual who signed the document to which this certificate is attached, and not the truthfulness, accuracy, or validity of that document.

State of California

County of Riverside

On 01/14/2025 before me, Kathryn Marconi, Notary Public,  
Date Here Insert name and Title of the Officer

personally appeared Edward J. Carlson  
Name(s) of Signer(s)

who proved to me on the basis of satisfactory evidence to be the person(s) whose name(s) is/are subscribed to the within instrument and acknowledged to me that he/she/they executed the same in his/her/their authorized capacity(ies), and that by his/her/their signature(s) on the instrument the person(s), or the entity upon behalf of which the person(s) acted, executed the instrument.

I certify under PENALTY OF PERJURY under the laws of the State of California that the forgoing paragraph is true and correct.

WITNESS my hand and official seal.

Signature Kathryn Marconi  
Signature of Notary Public



Place Notary Seal Above

**OPTIONAL**

Though the information below is not required by law, it may prove valuable to person relying on the document and could prevent fraudulent removal and reattachment of this form to another document.

**Description of Attached Document**

Title or Type of Document Bidder's Information Sheet - (City of Industry)

Document Date: 01/14/2025 Number of Pages: Two (2)

Signer(s) Other Than Named Above: N/A

**Capacity(ies) Claimed by Signer(s)**

Signer's Name: Edward J. Carlson

- Individual
- Corporate Officer — Title(s): Vice President
- Partner  Limited  General
- Attorney in Fact
- Trustee
- Other: \_\_\_\_\_

Signer is Representing:  
All American Asphalt

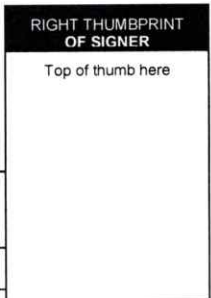

Signer's Name: \_\_\_\_\_

- Individual
- Corporate Officer — Title(s): \_\_\_\_\_
- Partner  Limited  General
- Attorney in Fact
- Trustee
- Other: \_\_\_\_\_

Signer is Representing: \_\_\_\_\_

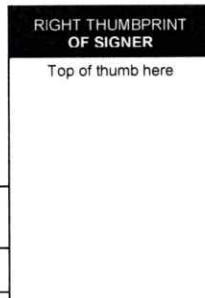



**CALIFORNIA ALL-PURPOSE ACKNOWLEDGEMENT**

**CIVIL CODE § 1189**

A notary public or other officer completing this certificate verifies only the identity of the individual who signed the document to which this certificate is attached, and not the truthfulness, accuracy, or validity of that document.

State of California

County of Riverside

On 01/14/2025 before me, Kathryn Marconi, Notary Public  
Date Here Insert name and Title of the Officer

personally appeared Edward J. Carlson  
Name(s) of Signer(s)

who proved to me on the basis of satisfactory evidence to be the person(s) whose name(s) is/are subscribed to the within instrument and acknowledged to me that he/she/they executed the same in his/her/their authorized capacity(ies), and that by his/her/their signature(s) on the instrument the person(s), or the entity upon behalf of which the person(s) acted, executed the instrument.

I certify under PENALTY OF PERJURY under the laws of the State of California that the forgoing paragraph is true and correct.

WITNESS my hand and official seal.



Place Notary Seal Above

Signature Kathryn Marconi  
Signature of Notary Public

**OPTIONAL**

Though the information below is not required by law, it may prove valuable to person relying on the document and could prevent fraudulent removal and reattachment of this form to another document.

**Description of Attached Document**

Title or Type of Document Contractor's License Affidavit

Document Date: 01/14/2025 Number of Pages: One (1)

Signer(s) Other Than Named Above: N/A

**Capacity(ies) Claimed by Signer(s)**

Signer's Name: Edward J. Carlson

- Individual
- Corporate Officer — Title(s): Vice President
- Partner  Limited  General
- Attorney in Fact
- Trustee
- Other: \_\_\_\_\_

**RIGHT THUMBPRINT OF SIGNER**

Top of thumb here

Signer is Representing:  
All American Asphalt

Signer's Name: \_\_\_\_\_

- Individual
- Corporate Officer — Title(s): \_\_\_\_\_
- Partner  Limited  General
- Attorney in Fact
- Trustee
- Other: \_\_\_\_\_

**RIGHT THUMBPRINT OF SIGNER**

Top of thumb here

Signer is Representing: \_\_\_\_\_

**BIDDER'S LIST OF CONSTRUCTION TRADES**

In submitting this bid for the following project:

CITY OF INDUSTRY  
PROJECT NO. 528

ANNUAL PAVEMENT REHABILITATION FY 23

CONTRACT NO. CITY-1528

All American Asphalt \_\_\_\_\_ certifies that:  
Bidder

The following listed construction trades will be used in the work.

- |  |   |   |  |
|--|---|---|--|
| <input type="checkbox"/> ASBESTOS            | <input type="checkbox"/> BOILERMAKER              | <input type="checkbox"/> BRICKLAYERS              | <input type="checkbox"/> CARPENTERS      |
| <input type="checkbox"/> CARPET/LINOLEUM     | <input checked="" type="checkbox"/> CEMENT MASONS | <input type="checkbox"/> DRYWALL FINISHER         | <input type="checkbox"/> DRYWALL/LATHERS |
| <input type="checkbox"/> ELECTRICIANS        | <input type="checkbox"/> ELEVATOR MECHANIC        | <input type="checkbox"/> GLAZIERS                 | <input type="checkbox"/> IRON WORKERS    |
| <input checked="" type="checkbox"/> LABORERS | <input type="checkbox"/> MILLWRIGHTS              | <input checked="" type="checkbox"/> OPERATING ENG | <input type="checkbox"/> PAINTERS        |
| <input type="checkbox"/> PILE DRIVERS        | <input type="checkbox"/> PIPE TRADES              | <input type="checkbox"/> PLASTERERS               | <input type="checkbox"/> ROOFERS         |
| <input type="checkbox"/> SHEET METAL         | <input type="checkbox"/> SOUND/COMM               | <input type="checkbox"/> SURVEYORS                | <input type="checkbox"/> TEAMSTER        |
| <input type="checkbox"/> TILE WORKERS        |   |   |  |

  
\_\_\_\_\_  
Signature of Authorized  
Representative of Bidder  
Edward J Carlson, Vice President

**NON-COLLUSION DECLARATION**

CITY OF INDUSTRY  
PROJECT NO. 528

ANNUAL PAVEMENT REHABILITATION FY 23

CONTRACT NO. CITY-1528

CONTRACTOR:

All American Asphalt  
\_\_\_\_\_

BUSINESS ADDRESS:

400 East Sixth Street Corona, CA 92879  
\_\_\_\_\_  
\_\_\_\_\_

In submitting this bid for the project:

I, Edward J Carlson, state that I have not directly or indirectly,  
(Name)  
entered into any agreement, participated in any collusion or otherwise taken any action in restraint  
of free competitive bidding in connection with the project.

I do hereby certify under penalty of perjury under the laws of the State of California that the  
foregoing is true and correct. Executed at Corona, California

California, this 14<sup>th</sup> day of January, 2025

  
\_\_\_\_\_  
SIGNATURE

Edward J Carlson, Vice President

**Note:**

- **The signature on this form (Non-Collusion Declaration, Page C-12) must be acknowledged before a Notary Public with an Acknowledgement Form attached.**
- **If any person is signing as attorney-in-fact, evidence of the authority for that must be attached as well.**

**CALIFORNIA ALL-PURPOSE ACKNOWLEDGEMENT**

**CIVIL CODE § 1189**

A notary public or other officer completing this certificate verifies only the identity of the individual who signed the document to which this certificate is attached, and not the truthfulness, accuracy, or validity of that document.

State of California

County of Riverside

On 01/14/2025 before me, Kathryn Marconi, Notary Public,  
Date Here Insert name and Title of the Officer

personally appeared Edward J. Carlson  
Name(s) of Signer(s)

who proved to me on the basis of satisfactory evidence to be the person(s) whose name(s) is/are subscribed to the within instrument and acknowledged to me that he/she/they executed the same in his/her/their authorized capacity(ies), and that by his/her/their signature(s) on the instrument the person(s), or the entity upon behalf of which the person(s) acted, executed the instrument.

I certify under PENALTY OF PERJURY under the laws of the State of California that the forgoing paragraph is true and correct.

WITNESS my hand and official seal.

Signature Kathryn Marconi  
Signature of Notary Public



Place Notary Seal Above

**OPTIONAL**

Though the information below is not required by law, it may prove valuable to person relying on the document and could prevent fraudulent removal and reattachment of this form to another document.

**Description of Attached Document**

Title or Type of Document Non-Collusion Declaration

Document Date: 01/14/2025 Number of Pages: One (1)

Signer(s) Other Than Named Above: N/A

**Capacity(ies) Claimed by Signer(s)**

Signer's Name: Edward J. Carlson

- Individual
- Corporate Officer — Title(s): Vice President
- Partner  Limited  General
- Attorney in Fact
- Trustee
- Other: \_\_\_\_\_

Signer is Representing:  
All American Asphalt

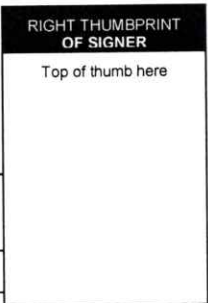

Signer's Name: \_\_\_\_\_

- Individual
- Corporate Officer — Title(s): \_\_\_\_\_
- Partner  Limited  General
- Attorney in Fact
- Trustee
- Other: \_\_\_\_\_

Signer is Representing: \_\_\_\_\_

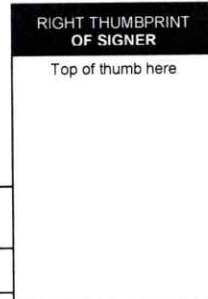

**CONTRACTOR REFERENCE VERIFICATION**

CITY OF INDUSTRY  
PROJECT NO. 528

ANNUAL PAVEMENT REHABILITATION FY 23

CONTRACT NO. CITY-1528

CONTRACTOR: All American Asphalt

Company: City of Irvine  
Address: 1 CIVIC CENTER PLAZA  
IRVINE, CA 92606

Contact Name: STACY DELONG  
Title: ENGINEER  
Phone Number: 949-724-7365

Email: SDELONG@CITYOFIRVINE.ORG

Project Description: JAMBOREE PAVEMENT REHABILITATION

Date of Completion: 12/2024 Awarded \$ amount: 7,869,222.00

Comments: \*\*N/A\*\*

Company: CITY OF MONTEREY PARK  
Address: 320 W NEWMARK AVE.  
MONTEREY PARK, CA 91754

Contact Name: ANTHONY BENDEZU  
Title: ENGINEER  
Phone Number: 626-307-1283

Email: ABENDEZY@MONTEREYPARK.CA.GOV

Project Description: 2023 STREET REHABILITATION PROJECT

Date of Completion: 12/2023 Awarded \$ amount: 6,865,699.00

Comments: \*\*N/A\*\*

\_\_\_\_\_  
\_\_\_\_\_  
Company: \_\_\_\_\_ Contact Name: \_\_\_\_\_  
Address: \_\_\_\_\_ Title: \_\_\_\_\_  
\_\_\_\_\_  
Phone Number: \_\_\_\_\_

Email: \_\_\_\_\_ **\*\*See attached recent completed construction projects\*\***

Project Description: \_\_\_\_\_  
\_\_\_\_\_  
\_\_\_\_\_

Date of Completion: \_\_\_\_\_ Awarded \$ amount: \_\_\_\_\_

Comments: \_\_\_\_\_  
\_\_\_\_\_  
\_\_\_\_\_

# 2024

## PAST WORK REFERENCES

City of Riverside  
3900 Main St.  
Riverside, CA 92502  
Contact: Mark Mesen (951) 826-5311  
[mmensen@riversideca.gov](mailto:mmensen@riversideca.gov)

SB-1 St. Improvement  
Contract Amount: \$8,965,842.76  
Start Date: 4/2023  
End Date: 1/2024

Lewis Management Corporation  
1156 N. Mountain Ave.  
Upland, CA 91786  
Contact: Daniel Coburn (909) 985-0971  
[Daniel.coburn@lewismc.com](mailto:Daniel.coburn@lewismc.com)

Haven Avenue and Fourth Street  
Improvements  
Contract Amount: \$1,338,174.90  
Start Date: 6/2023  
End Date: 7/2024

City of Irvine  
1 Civic Center Plaza  
Irvine, CA 92606  
Contact: Stacy DeLong (949) 724-7365  
[sdelong@cityofirvine.org](mailto:sdelong@cityofirvine.org)

Jamboree Pavement Rehabilitation  
Contract Amount: \$7,869,222.00  
Start Date: 6/2023  
End Date: 12/2024

City of Duarte  
1600 Huntington Dr.  
Duarte, CA 91010  
Contact: Brian Chau (626)357-7938  
[bchau@accessduarte.com](mailto:bchau@accessduarte.com)

FY 23-24 Street Rehabilitation  
Project 24-3  
Contract Amount: \$1,199,199.00  
Start Date: 4/2024  
End Date: 12/2024

City of Norwalk  
12700 Norwalk Blvd.  
Norwalk, CA 90650  
Contact: Glen W.C. Kau (562) 929-5723  
[gkau@norwalkca.gov](mailto:gkau@norwalkca.gov)

Local Streets Rehab Program Ph II  
Zone 19  
Contract Amount: \$7,869,222.00  
Start Date: 6/2023  
End Date: 12/2024

# 2024

## PAST WORK REFERENCES

City of Monterey Park  
320 W Newmark Ave.  
Monterey Park, CA 91754  
Contact: Anthony Bendezu (626) 307-1283  
[abendezy@montereypark.ca.gov](mailto:abendezy@montereypark.ca.gov)

2023-24 Street Rehabilitation Various  
Locations  
Contract Amount: \$1,498,887.89  
Start Date: 9/2023  
End Date: 12/2024

Lennar Homes  
4140 Temescal Canyon RD#410  
Corona, CA. 92883  
Contact: Tom Ontiveros (951) 817-3595  
[Thomas.ontiveros@Lennar.com](mailto:Thomas.ontiveros@Lennar.com)

Goetz Road Improvements  
Contract Amount: \$1,322,050.15  
Start Date: 5/2024  
End Date: 12/2024

City of El Monte  
11333 Valley Blvd.  
El Monte, CA 91731  
Contact: Kevin Ko (626) 580-2058  
[Kko@elmonteca.gov](mailto:Kko@elmonteca.gov)

Lower Azusa RD St. Improvements  
Contract Amount: \$2,194,194.00  
Start Date: 5/2024  
End Date: 12/2024

City of Costa Mesa  
77 Fair Drive  
Costa Mesa, CA 92626  
Contact: Cristina Oquendo (714) 754-5015  
[cristina.oquendo@costamesaca.gov](mailto:cristina.oquendo@costamesaca.gov)

Placentia Ave. W 19<sup>th</sup> St & E 19<sup>th</sup> St.  
Pavement Rehabilitation 22-08  
Contract Amount: \$2,745,547.20  
Start Date: 2/2023  
End Date: 7/2024

City of Corona  
400 S. Vicentia Ave.  
Corona, CA 92882  
Contact: Ismael Rivera (951) 736-2400  
[Ismael.Rivera@CoronaCA.gov](mailto:Ismael.Rivera@CoronaCA.gov)

Citywide Street Pavement Rehabilitation  
Project ST-2101-01  
Contract Amount: \$14,236,115.51  
Start Date: 12/2023  
End Date: 7/2025

# 2023

## PAST WORK REFERENCES

City of Loma Linda  
25541 Barton Road  
Loma Linda, CA 92354  
Manhattan Beach, CA 90266  
Contact: Jarb Thaipejr (909) 799-2811  
[jthaipejr@lomalinda-ca.gov](mailto:jthaipejr@lomalinda-ca.gov)

Pavement Rehab. at Various Locations  
Contract Amount: \$1,476,363.00  
Start Date: 9/1/2023  
End Date: 12/2023

Euclid Land Venture, LLC  
4450 Macarthur Blvd., Ste 100  
Newport Beach, CA 92693  
Contact: Scott Kendall (949) 783-5341  
[khaymes@ranchomv.com](mailto:khaymes@ranchomv.com)

Merrill Ave. Street Widening  
Contract Amount: \$915,915.00  
Start Date: 4/2022  
End Date: 2/2023

City of Aliso Viejo  
12 Journey Ste #100  
Aliso Viejo, Va 92656  
Contact: Shaun Pelletier (949) 425-2531  
[spelletier@avcity.org](mailto:spelletier@avcity.org)

FY22-23 Slurry Seal & Rehab Project  
Contract Amount: \$1,595,650.00  
Start Date: 5/2022  
End Date: 5/2023

RMV Realty, Inc.  
28811 Ortega HWY  
San Juan Capistrano, CA 92693  
Contact: Jeff Ford (949) 413-8899  
[jford@ranchomv.com](mailto:jford@ranchomv.com)

PA 3.2A Street Improvement  
Contract Amount: \$1,244,244.00  
Start Date: 4/2022  
End Date: 8/2023

City of Monterey Park  
320 W. Newmark Avenue  
Monterey Park, CA 91754  
Contact: Anthony Bendezy (626) 307-1283  
[abendezy@montereypark.ca.gov](mailto:abendezy@montereypark.ca.gov)

2023 Street Rehabilitation Project  
Contract Amount: \$6,865,699.00  
Start Date: 8/2023  
End Date: 12/2023

# 2023

## PAST WORK REFERENCES

City of Fullerton  
303 W. Commonwealth Ave  
Fullerton, CA 92632  
Contact: Joseph Hernandez (714) 773-0049  
[JHernandez@cityoffullerton.com](mailto:JHernandez@cityoffullerton.com)

Brookhurst Rd., SR91 St. Rehab  
Contract Amount: \$325,825.00  
Start Date: 5/2023  
End Date: 12/2023

City of Ontario  
303 East B Street  
Ontario, CA 91764  
Contact: Leonard Lui (909) 295-2401  
[LLui@ontarioca.gov](mailto:LLui@ontarioca.gov)

2023 Fall Pavement Rehabilitation Project  
Contract Amount: \$4,569,222.00  
Start Date: 08/2023  
End Date: 11/2023

City of Riverside  
2900 Main St.  
Riverside, CA 92522  
Contact: Maria Lamping (951) 826-5146  
[mlamping@riversideca.gov](mailto:mlamping@riversideca.gov)

Permanent Trench Resurfacing  
Contract Amount: \$455,150.00  
Start Date: 1/2023  
End Date: 6/2023

City of Ontario  
825 East Third Street  
San Bernardino, CA 92415  
Contact: Samuel E. Nicorici (909) 387-7960  
[bdavis@newportbeachca.gov](mailto:bdavis@newportbeachca.gov)

Chino & Montclair Area Variours Roads  
Overlay Project  
Contract Amount: \$5,639,575.88  
Start Date: 9/2022  
End Date: 7/2023

City of Costa Mesa  
77 Fair Drive  
Costa Mesa, CA 92626  
Contact: Cristina Oquendo (714) 754-5015  
[cristina.oquendo@costamesaca.gov](mailto:cristina.oquendo@costamesaca.gov)

Citywide Parkway Maintenance St. Rehab  
Slurry Seal Project  
Contract Amount: \$2,828,001.50  
Start Date: 1/2022  
End Date: 7/2023

# 2022

## PAST WORK REFERENCES

City of Manhattan Beach  
1400 Highland Ave.  
Manhattan Beach, CA 90266  
Contact: Bianca Cardenas (310) 802-5357  
[bcardenas@manhattanbeach.gov](mailto:bcardenas@manhattanbeach.gov)

Slurry Seal of Central Area of Sands  
Section  
Contract Amount: \$730,251.42  
Start Date: 12/2021  
End Date: 7/2022

RMV Realty, Inc.  
28811 Ortega Hwy  
San Juan Capistrano, CA 92693  
Contact: Kelly Haymes  
[khaymes@ranchomv.com](mailto:khaymes@ranchomv.com)

Planning Area 3.1 Street Improvement  
Contract Amount: \$3,996,996.00  
Start Date: 4/2021  
End Date: 4/2022

City of Westlake Village  
31200 Oak Crest Dr.  
Westlake Village, CA 91361  
Contact: Roxanne Hughes (805) 890-8885  
[rhughes@willdan.com](mailto:rhughes@willdan.com)

Dales Dr. and Parkridge Ave Street Improv.  
Amount: \$1,025,336.00  
Start Date: 5/2022  
End Date: 6/2022

City of Burbank  
275 E Olive  
Burbank, CA 91502  
Contact: Artin Megerdichian (818) 238-3942  
[amegerdichian@burbankca.gov](mailto:amegerdichian@burbankca.gov)

Local Residential St. Improv. Project  
Contract Amount: \$7,761,320.00  
Start Date: 1/2022  
End Date: 12/2022

City of Highland  
27215 Base Line St.  
Highland, CA 92346  
Contact: Amanda Perez (909) 864-6861  
[aperez@cityofhighland.org](mailto:aperez@cityofhighland.org)

Pavement Management Program  
Contract Amount: \$2,082,099.00  
Start Date: 10/2021  
End Date: 12/2022

**BID BOND**

PROJECT NO. 528  
ANNUAL PAVEMENT REHABILITATION FY 23  
CONTRACT NO. CITY-1528

KNOW ALL MEN BY THESE PRESENTS that we All American Asphalt  
Fidelity and Deposit Company of Maryland as BIDDER, and Fidelity and Deposit Company of Maryland, a corporation organized and existing under the laws of the State of Illinois, and duly authorized to transact business under the laws of the State of California, as SURETY, are held and firmly bound unto the City of Industry ("CITY"), in the penal sum of Ten Percent of Total Amount Bid----- [IN WORDS] dollars (\$ 10% of Bid), which is 10 percent of the total amount bid by BIDDER to CITY for the above-stated project, for the payment of which sum, BIDDER and SURETY agree to be bound, jointly and severally, firmly by these presents.

THE CONDITIONS OF THIS OBLIGATION ARE SUCH that, whereas BIDDER is about to submit a bid to CITY for the above-stated project, if said bid is rejected, or if said bid is accepted and a contract is awarded and entered into by BIDDER in the manner and time specified, then this obligation shall be null and void, otherwise it shall remain in full force and effect in favor of CITY.

IN WITNESS WHEREOF the parties hereto have set their names, titles, hands, and seals this 18th day of March, 2025

**BIDDER:**

Name: All American Asphalt

Address: 400 East Sixth Street

Corona, CA 92879

By: Edward J Carson

Signature: [Signature]

Title: Vice President

**SURETY:**

Name: Fidelity and Deposit Company of Maryland

Address: 777 S. Figueroa Street, Suite 3900

Los Angeles, CA 90017

By: Rebecca Haas-Bates

Signature: [Signature]

Title: Attorney-in-Fact

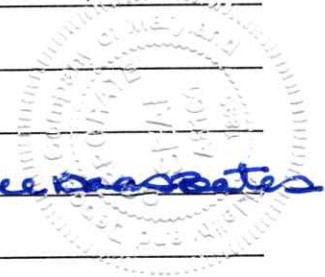

**Note:**

- The signature on this form (Bid Bond, Page A-12) must be acknowledged before a Notary Public with an Acknowledgement Form attached.
- If any person is signing as attorney-in-fact, evidence of the authority for that must be attached as well.

**CALIFORNIA ALL-PURPOSE ACKNOWLEDGEMENT**

**CIVIL CODE § 1189**

A notary public or other officer completing this certificate verifies only the identity of the individual who signed the document to which this certificate is attached, and not the truthfulness, accuracy, or validity of that document.

State of California

County of Riverside

On 03/20/2025 before me, Kathryn Marconi, Notary Public,  
Date Here Insert name and Title of the Officer

personally appeared Edward J. Carlson  
Name(s) of Signer(s)

who proved to me on the basis of satisfactory evidence to be the person(s) whose name(s) is/are subscribed to the within instrument and acknowledged to me that he/she/they executed the same in his/her/their authorized capacity(ies), and that by his/her/their signature(s) on the instrument the person(s), or the entity upon behalf of which the person(s) acted, executed the instrument.

I certify under PENALTY OF PERJURY under the laws of the State of California that the forgoing paragraph is true and correct.

WITNESS my hand and official seal.



Place Notary Seal Above

Signature Kathryn Marconi  
Signature of Notary Public

**OPTIONAL**

Though the information below is not required by law, it may prove valuable to person relying on the document and could prevent fraudulent removal and reattachment of this form to another document.

**Description of Attached Document**

Title or Type of Document Bid Bond

Document Date: 03/18/2025 Number of Pages: One (1)

Signer(s) Other Than Named Above: Rebecca Haas-Bates (Attorney in Fact)

**Capacity(ies) Claimed by Signer(s)**

Signer's Name: Edward J. Carlson

- Individual
- Corporate Officer — Title(s): Vice President
- Partner  Limited  General
- Attorney in Fact
- Trustee
- Other: \_\_\_\_\_

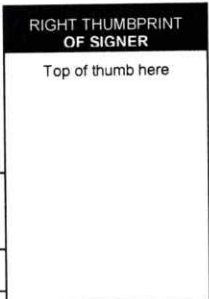

Signer is Representing:  
All American Asphalt

Signer's Name: \_\_\_\_\_

- Individual
- Corporate Officer — Title(s): \_\_\_\_\_
- Partner  Limited  General
- Attorney in Fact
- Trustee
- Other: \_\_\_\_\_

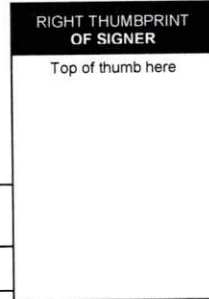

Signer is Representing: \_\_\_\_\_

**CALIFORNIA ALL-PURPOSE ACKNOWLEDGMENT**

**CIVIL CODE § 1189**

A notary public or other officer completing this certificate verifies only the identity of the individual who signed the document to which this certificate is attached, and not the truthfulness, accuracy, or validity of that document.

State of California )  
County of Orange )

On 03/18/2025 before me, L. Gomez, Notary Public  
*Date Here Insert Name and Title of the Officer*

personally appeared Rebecca Haas-Bates  
*Name(s) of Signer(s)*

who proved to me on the basis of satisfactory evidence to be the person(s) whose name(s) is/are subscribed to the within instrument and acknowledged to me that he/she/they executed the same in his/her/their authorized capacity(ies), and that by his/her/their signature(s) on the instrument the person(s), or the entity upon behalf of which the person(s) acted, executed the instrument.

I certify under PENALTY OF PERJURY under the laws of the State of California that the foregoing paragraph is true and correct.

WITNESS my hand and official seal.

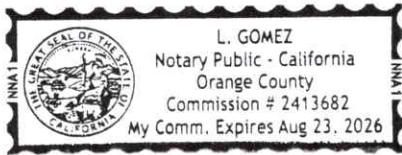

Signature *L. Gomez*  
*Signature of Notary Public*

*Place Notary Seal Above*

**OPTIONAL**

*Though this section is optional, completing this information can deter alteration of the document or fraudulent reattachment of this form to an unintended document.*

**Description of Attached Document**

Title or Type of Document: Bid Bond Document Date: 03/18/2025  
Number of Pages: One(1) Signer(s) Other Than Named Above: All American Asphalt

**Capacity(ies) Claimed by Signer(s)**

Signer's Name: Rebecca Haas-Bates  
 Corporate Officer — Title(s): \_\_\_\_\_  
 Partner —  Limited  General  
 Individual  Attorney in Fact  
 Trustee  Guardian or Conservator  
 Other: \_\_\_\_\_  
Signer Is Representing: \_\_\_\_\_  
Fidelity and Deposit Company of Maryland

Signer's Name: \_\_\_\_\_  
 Corporate Officer — Title(s): \_\_\_\_\_  
 Partner —  Limited  General  
 Individual  Attorney in Fact  
 Trustee  Guardian or Conservator  
 Other: \_\_\_\_\_  
Signer Is Representing: \_\_\_\_\_

**EXTRACT FROM BY-LAWS OF THE COMPANIES**

"Article V, Section 8, Attorneys-in-Fact. The Chief Executive Officer, the President, or any Executive Vice President or Vice President may, by written instrument under the attested corporate seal, appoint attorneys-in-fact with authority to execute bonds, policies, recognizances, stipulations, undertakings, or other like instruments on behalf of the Company, and may authorize any officer or any such attorney-in-fact to affix the corporate seal thereto; and may with or without cause modify or revoke any such appointment or authority at any time."

**CERTIFICATE**

I, the undersigned, Vice President of the ZURICH AMERICAN INSURANCE COMPANY, the COLONIAL AMERICAN CASUALTY AND SURETY COMPANY, and the FIDELITY AND DEPOSIT COMPANY OF MARYLAND, do hereby certify that the foregoing Power of Attorney is still in full force and effect on the date of this certificate; and I do further certify that Article V, Section 8, of the By-Laws of the Companies is still in force.

This Power of Attorney and Certificate may be signed by facsimile under and by authority of the following resolution of the Board of Directors of the ZURICH AMERICAN INSURANCE COMPANY at a meeting duly called and held on the 15th day of December 1998.

RESOLVED: "That the signature of the President or a Vice President and the attesting signature of a Secretary or an Assistant Secretary and the Seal of the Company may be affixed by facsimile on any Power of Attorney...Any such Power or any certificate thereof bearing such facsimile signature and seal shall be valid and binding on the Company."

This Power of Attorney and Certificate may be signed by facsimile under and by authority of the following resolution of the Board of Directors of the COLONIAL AMERICAN CASUALTY AND SURETY COMPANY at a meeting duly called and held on the 5th day of May, 1994, and the following resolution of the Board of Directors of the FIDELITY AND DEPOSIT COMPANY OF MARYLAND at a meeting duly called and held on the 10th day of May, 1990.

RESOLVED: "That the facsimile or mechanically reproduced seal of the company and facsimile or mechanically reproduced signature of any Vice-President, Secretary, or Assistant Secretary of the Company, whether made heretofore or hereafter, wherever appearing upon a certified copy of any power of attorney issued by the Company, shall be valid and binding upon the Company with the same force and effect as though manually affixed.

IN TESTIMONY WHEREOF, I have hereunto subscribed my name and affixed the corporate seals of the said Companies, this 18th day of March, 2025.



*MJ Pethick*

Mary Jean Pethick  
Vice President

**TO REPORT A CLAIM WITH REGARD TO A SURETY BOND, PLEASE SUBMIT A COMPLETE DESCRIPTION OF THE CLAIM INCLUDING THE PRINCIPAL ON THE BOND, THE BOND NUMBER, AND YOUR CONTACT INFORMATION TO:**

Zurich Surety Claims  
1299 Zurich Way  
Schaumburg, IL 60196-1056  
[reportsfclaims@zurichna.com](mailto:reportsfclaims@zurichna.com)  
800-626-4577

**Authenticity of this bond can be confirmed at [bondvalidator.zurichna.com](http://bondvalidator.zurichna.com) or 410-559-8790**

City of Industry

Bid Results for Project ANNUAL PAVEMENT REHABILITATION FY 23 (CITY-1528)

Issued on 12/19/2024

Bid Due on April 03, 2025 10:00 AM (PDT)

Exported on 04/03/2025

Line Totals (Unit Price \* Quantity)

Item Num	Description	Unit of Measure	Qty	All American Asphalt - Unit Price	All American Asphalt - Line Total
1	MOBILIZATION	LS	1	\$250,000.00	\$250,000.00
2	PREPRATION AND IMPLEMENTATION OF STORM WATER POLLUTION PREVENTION PLAN	LS	1	\$13,500.00	\$13,500.00
3	TRAFFIC CONTROL	LS	1	\$265,000.00	\$265,000.00
4	BONELLI STREET AERIALY DEPOSITED LEAD TESTING	LS	1	\$7,800.00	\$7,800.00
5	HAZARDOUS WASTE DISPOSAL	ALLOW	1	\$150,000.00	\$150,000.00
6	REMOVE AC PAVEMENT (BONELLI STREET)	SY	10500	\$19.00	\$199,500.00
7	COLD MILL EXISTING AC PAVEMENT, 2-1/2"	SY	84700	\$6.85	\$580,195.00
8	COLD MILL AC PAVEMENT 2-1/2" DEPTH BELOW LIP OF GUTTER, TAPERING TO 0 INCH DEPTH, DISTANCE PER PLAN FROM EDGE OFF PCC PAVEMENT/GUTTER	SY	19575	\$4.50	\$88,087.50
9	UNCLASSIFIED EXCAVATION (BONELLI STREET)	CY	4400	\$135.00	\$594,000.00
10	CONSTRUCT STREET PAVE-OUT PER CITY OF INDUSTRY STD PLAN NO. 111	SF	2100	\$32.00	\$67,200.00
11	SAWCUT AND REMOVE EXISTING SIDEWALK INCLUDING AGGREGATE BASE	SF	925	\$11.00	\$10,175.00
12	SAWCUT AND REMOVE EXISTING PCC CURB AND GUTTER INCLUDING AGGREGATE BASE	LF	420	\$32.00	\$13,440.00
13	SAWCUT AND REMOVE EXISTING PCC CURB AND GUTTER INCLUDING AGGREGATE BASE (BONELLI STREET)	LF	450	\$32.00	\$14,400.00
14	SAWCUT AND REMOVE EXISTING DRIVEWAY, INCLUDING AGGREGATE BASE	SF	6000	\$12.00	\$72,000.00

Item Num	Description	Unit of Measure	Qty	All American Asphalt - Unit Price	All American Asphalt - Line Total
15	SAWCUT AND REMOVE EXISTING DRIVEWAY, INCLUDING AGGREGATE BASE (BONELLI STREET)	SF	6200	\$12.00	\$74,400.00
16	SAWCUT AND REMOVE PEDESTRIAN RAMP, INCLUDING AGGREGATE BASE	SF	4310	\$10.00	\$43,100.00
17	SAWCUT AND REMOVE PEDESTRIAN RAMP, INCLUDING AGGREGATE BASE (BONELLI STREET)	SF	420	\$10.00	\$4,200.00
18	ASPHALT CONCRETE PAVEMENT	TON	19950	\$128.00	\$2,553,600.00
19	CRUSHED AGGREGATE BASE	CY	4600	\$50.00	\$230,000.00
20	FURNISH AND INSTALL 3/8" ASPHALT RUBBER AND AGGREGATE MEMBRANE (ARAM)	SY	51640	\$5.00	\$258,200.00
21	Tensar InterAX NXP GEOGRID, OR APPROVED EQUAL	SY	10500	\$12.00	\$126,000.00
22	CONSTRUCT CONCRETE PAVEMENT TRANSITION PANEL PER CALTRANS STANDARD PLAN NO. P30.	SF	525	\$50.00	\$26,250.00
23	CONSTRUCT TYPE A2-8 PCC CURB AND GUTTER (W=2') PER CITY OF INDUSTRY STD. PLAN NO. 112	LF	930	\$70.00	\$65,100.00
24	CONSTRUCT PCC CURB AND GUTTER FOR DRIVEWAYS PER CITY OF INDUSTRY STD. PLAN NO. 114	LF	200	\$70.00	\$14,000.00
25	CONSTRUCT PEDESTRIAN RAMP, INCLUDING DETECTABLE WARNING SURFACE PER CALTRANS STANDARD PLAN NO. A88A, CASE PER PLAN	SF	5100	\$35.00	\$178,500.00
26	CONSTRUCT PCC DRIVEWAY PER DETAIL B, SHEET 2, INCLUDING ADJACENT CURB AND GUTTER	SF	12200	\$25.00	\$305,000.00
27	CONSTRUCT 4" PCC SIDEWALK PER CITY OF INDUSTRY STD. PLAN NO 115	SF	925	\$16.00	\$14,800.00
28	ADJUST MANHOLE COVER AND FRAME TO FINISHED GRADE	EA	77	\$1,400.00	\$107,800.00
29	ADJUST WATER OR GAS VALVE COVER AND FRAME TO FINISHED GRADE.	EA	74	\$600.00	\$44,400.00
30	RESTORE TRAFFIC LOOP DETECTORS	EA	33	\$495.00	\$16,335.00
31	REPAINT CURB RED	LF	33100	\$2.00	\$66,200.00
32	REPAINT RED CURB (BONELLI STREET)	LF	3200	\$2.00	\$6,400.00

Item Num	Description	Unit of Measure	Qty	All American Asphalt - Unit Price	All American Asphalt - Line Total
33	REPAINT YELLOW CURB	LF	140	\$2.00	\$280.00
34	PAVEMENT MARKERS, MARKINGS AND TRAFFIC STRIPING	LS	1	\$120,000.00	\$120,000.00
35	RESTORE DRIVEWAY LOOP DETECTOR	EA	1	\$495.00	\$495.00
					\$6,580,357.50
					<b>\$6,580,357.50</b>



## CONTRACTORS STATE LICENSE BOARD

# Contractor's License Detail for License # 267073

**DISCLAIMER: A license status check provides information taken from the CSLB license database. Before relying on this information, you should be aware of the following limitations.**

- ▶ CSLB complaint disclosure is restricted by law (B&P 7124.6) If this entity is subject to public complaint disclosure click on link that will appear below for more information. Click [here](#) for a definition of disclosable actions.
- ▶ Only construction related civil judgments reported to CSLB are disclosed (B&P 7071.17).
- ▶ Arbitrations are not listed unless the contractor fails to comply with the terms.
- ▶ Due to workload, there may be relevant information that has not yet been entered into the board's license database.

Data current as of 4/14/2025 4:57:01 PM

### Business Information

ALL AMERICAN ASPHALT  
P O BOX 2229  
CORONA, CA 92878  
Business Phone Number:(951) 736-7600

**Entity** Corporation  
**Issue Date** 01/19/1971  
**Expire Date** **01/31/2026**

### License Status

**This license is current and active.**

**All information below should be reviewed.**

### Classifications

- ▶ [A - GENERAL ENGINEERING](#)
- ▶ [C12 - EARTHWORK AND PAVING](#)

### Bonding Information

#### Contractor's Bond

This license filed a Contractor's Bond with [FIDELITY AND DEPOSIT COMPANY OF MARYLAND](#).

**Bond Number:** 08727441

**Bond Amount:** \$25,000

**Effective Date:** 01/01/2023

[Contractor's Bond History](#)

#### Bond of Qualifying Individual

This license filed Bond of Qualifying Individual number **LPM7627119** for MARK ALBERT LUER in the amount of **\$25,000** with [FIDELITY AND DEPOSIT COMPANY OF MARYLAND](#).

**Effective Date:** 01/01/2023

[BQI's Bond History](#)

### Workers' Compensation

This license has workers compensation insurance with the [ZURICH AMERICAN INSURANCE COMPANY](#)

**Policy Number:** WC593205711

**Effective Date:** 08/01/2024

**Expire Date:** 08/01/2025

[Workers' Compensation History](#)

Other

▶ Personnel listed on this license (current or disassociated) are listed on other licenses.

[Back to Top](#)

[Privacy Policy](#)

[Accessibility Certification](#)

Copyright © 2025 State of California

[Conditions of Use](#)

[Accessibility](#)



[eCPR Public Search](#)

[Log in](#)

[Public Works Support](#)

[Contractors](#)

[Projects](#)

[Register](#)

[Home](#) > [Customer Account Lookup](#) > [All American Asphalt](#)

All American Asphalt

## Customer Account Lookup

Name

All American Asphalt

Customer Account



All American Asphalt

Type

Contractor

Website

(empty)



Email

publicworks@allamericanasphalt.com

Address 1

400 E SIXTH ST

Address\_2

City

CORONA

State

CA

Zip

92879

Contractor Status

DIR Approved

CSLB

267073

Legal Name

ALL AMERICAN ASPHALT

Business Structure

-- None --

Business Phone

951-736-7600

Registration Number

President

Mark Luer

PWCR

1000001051

Registration Start Date

2023-07-01

Registration End Date

2026-06-30

Doing Business As (DBA)

Crafts

Operating Engineer Laborer and Related Classifications

Parking and Highway Improvement (Striping, Slurry and Seal Coat Operations-Laborer)

Cement Mason

Legacy Registration Date

2023-07-01

Legacy Registration Expiration

2026-06-30

## Related Lists

[Historical Registration Dates](#) (1)

[Terms & Conditions](#)

[Privacy Policy](#)

[Disclaimer](#)

[Nondiscrimination Notice](#)

Copyright 2024 State of California

[Accessibility](#)

[dir.ca.gov](#)

**NOTICE OF EXEMPTION**

**To:** County Clerk  
County of Los Angeles  
Environmental Filings  
12400 East Imperial Highway #2001  
Norwalk, CA 90650

**From:** City of Industry  
15625 Mayor Dave Way  
City of Industry, CA 91744

**Project Title:** CITY-1528 – Annual Pavement Rehabilitation FY 23

**Project Location - Specific:** Stafford Street, Hudson Avenue, Hacienda Boulevard, Gale Avenue, Castleton Street, Albatross Road, Newquist Place, Canal Place, Loudon Lane, Bonelli Street, Temple Avenue

**Project Location-City:** City of Industry **Project Location-County:** Los Angeles

**Description of Project:** Resurfacing of City streets including, cold milling of existing asphalt concrete (“AC”) pavement, constructing AC pavement overlay, repairing broken curbs, gutter, driveways, and sidewalks, upgrading curb ramps to current ADA standards, adjusting existing utilities to finish grade, pavement markings, striping and red curb throughout. Work also includes the complete reconstruction of existing AC pavement section on Bonelli Street. Work includes the removal of existing asphalt concrete pavement and aggregate base and replacing with new AC pavement on crushed aggregate base on one layer of geogrid between subgrade and aggregate base.

**Name of Public Agency Approving Project:** City of Industry

**Name of Person or Agency Carrying Out Project:** City of Industry

**Exempt Status:** *(check one)*

- Ministerial (Sec. 21080(b)(1); 15268);
- Declared Emergency (Sec. 21080(b)(3); 15269(a));
- Emergency Project (Sec. 21080(b)(4); 15269(b)(c));
- Categorical Exemption. *State type and section number:* 15301 Class 1
- Statutory Exemptions. *State code number:*

**Reasons why project is exempt:** The proposed project is exempt from the California Environmental Quality Act (“CEQA”) per Section 15301 Class 1 of the CEQA Regulations in which the minor alteration of existing public or private structures or facilities involve negligible or no expansion of existing use. This project will reconstruct the existing pavement section on Bonelli Street and cold mill existing AC and new AC overlay for the rest of the streets; repair broken curbs, gutters, driveways, and sidewalks, upgrade curb ramps to current ADA standard, adjust existing utility covers to finish grade, and install pavement markings, striping, and re-paint red curb throughout. The project does not result in an expansion of the use, as the streets are not being expanded to allow for additional traffic, it’s simply routine maintenance work.

**Lead Agency**

Contact Person: Mathew Hudson Telephone: (626) 333-2211

Signature: \_\_\_\_\_ Date: April 24, 2025

Title: Director of Public Works

ITEM NO. 6.5



# CITY OF INDUSTRY

## MEMORANDUM

**TO:** Honorable Mayor and Members of the City Council

**FROM:** Joshua Nelson, City Manager

**STAFF:** Mathew Hudson, Director of Public Works  
James Cramsie, Sr. Director of Engineering  
Arlene Lopez, Sr. Project Manager

**DATE:** April 24, 2025

**SUBJECT:** Consideration of authorization to advertise for public bids for Contract No. CITY-1439, San Jose Reconstruction from 500 feet West of Nogales Street to 500 feet West of Charlie Road, for an estimated cost of \$5,397,000.00 (MP 08-09)

---

### **Background:**

San Jose Avenue narrows from two west-bound lanes east of Charlie Road to a single through lane at the intersection, then widens back to two lanes approximately west of the intersection. The existing configuration forces a left-only turn onto Charlie Road, and a single through lane on San Jose Avenue. The project would reconfigure the intersection to enable both the left turn lane and two through lanes travelling west bound on San Jose Road. Once completed, the project will improve efficiency for through-traffic by connecting the travel lanes on either side of the intersection and reducing congestion at this intersection by continuing a left-turn lane. In addition, the pavement on San Jose Avenue has deteriorated, and a full reconstruction of the pavement is needed for the rehabilitation of this heavily used thoroughfare. Staff has prepared plans and specifications for the above project. This project will be implemented as Contract No. CITY-1439, subject to approval by the City Council.

### **Discussion:**

The scope of work involves relocating the northerly curb six feet to the north from just west of Charlie Road to approximately 365 feet east of Charlie Road. It also includes removal of the existing asphalt concrete pavement ("AC") and reconstructing with new AC pavement on crushed aggregate base with two layers of geogrid to strengthen the subgrade. The existing street lighting system will be removed and replaced with a new street light system to improve lighting along San Jose Avenue. The existing street trees will be removed to accommodate the new street lighting system and new street trees will be planted throughout the project limits. ADA accessibility will be improved with the reconstruction of existing curb ramps, sidewalk, and

driveways, and curb and gutter will be reconstructed where necessary. Finally, the work includes pavement markers, markings, and traffic striping.

This project was previously authorized by the City Council to advertise for public bids on May 26, 2022. There were delays in the project due to right-of-way issues and the impacts to some properties. Additionally, the plans and specifications were revised thereafter to include power and fiber optics conduits, vaults, and pull boxes for future use by the City. Since the street pavement section will be completely reconstructed, it is cost-effective to add power and fiber optics conduit and other substructure at this time.

**Fiscal Impact:**

The estimated cost for this project is \$5,397,000.00.

**Recommendation:**

It is hereby recommended that the City Council approve the plans and specifications and authorize the solicitation of the public bids.

**Exhibits:**

1. Notice Inviting Bids
2. Engineer's Estimate
3. Section A Pages A-1 through A-8
4. Reduced Set of Project Plans

**NOTICE INVITING BIDS FOR:**

**CITY OF INDUSTRY  
PROJECT NO. 439**

**SAN JOSE AVENUE RECONSTRUCTION 500' WEST OF NOGALES STREET TO 400' WEST  
OF CHARLIE ROAD**

CONTRACT NO. CITY-1439

The **CITY OF INDUSTRY**, hereinafter referred to as the **CITY**, will receive bids for the construction of the above project until **10:00 A.M.** on **Wednesday, June 4, 2025**, via the City of Industry's PlanetBids™ vendor portal. Bids are to be submitted through <https://www.planetbids.com/portal/portal.cfm?CompanyID=29042>.

Postmarks, mailed, emailed, or hard copy bids will not be accepted. Late bids will not be accepted.

It is the responsibility of the bidder to be sure the bid is submitted prior to the date and time indicated above. Free digital versions of the plans and specifications are available on the vendor portal. Hard copies are no longer available for purchase.

At the time of submission of the bid and thereafter, each bidder must be licensed as a **Class A - General Engineering** as defined in Sections 7055-7058 of the Business and Professions Code. Each bidder shall set forth on the Bidder's Information Sheet and the Contractor's License Affidavit the classification and number of the requisite license which that bidder holds.

The **CITY** reserves the right to award the contract to the contractor with another license class if the **CITY** determines that the license class is proper for the proposed work.

A contractor or subcontractor shall not be qualified to bid on, be listed in a bid proposal, subject to the requirements of Section 4104 of the Public Contract Code, or engage in the performance of any contract for public work, as defined in this chapter, unless currently registered and qualified to perform public work pursuant to Section 1725.5. **Please note:** *It is not a violation of this section for an unregistered contractor to submit a bid that is authorized by Section 7029.1 of the Business and Professions Code or by Section 10164 or 20103.5 of the Public Contract Code, provided the contractor is registered to perform public work pursuant to Section 1725.5 at the time the contract is awarded.* Any bids submitted without proof that bidder and any listed subcontractor(s) are currently registered and qualified to perform public work, pursuant to Labor Code Section 1725.5, may not be accepted by the CITY.

The Scope of Work is as follows: Removal of existing AC pavement section and reconstructing with new AC pavement on crushed aggregate base (CAB) with 2-layers of geogrid; removal of existing street light poles and foundations; installation of new street light system; removal of existing street trees and planting of new street trees; restoration of landscaping and irrigation; reconstruction and repair of PCC curb & gutters, sidewalks, driveways, and curb ramps; installation of new power duct bank; and pavement markers, markings and striping.

Online Questions and Answers will be due via the City of Industry's PlanetBids™ vendor portal on **Friday, May 23, 2025 at 5:00 P.M.**

**CITY OF INDUSTRY  
PROJECT NO. 439**

**SAN JOSE AVENUE RECONSTRUCTION 500' WEST OF NOGALES STREET TO 400' WEST  
OF CHARLIE ROAD**

CONTRACT NO. CITY-1439

Each bid shall be accompanied by a bid guarantee in the form of a Cashier's Check or Bidder's Bond for not less than ten percent (10%) of the total amount of the bid, made payable to the **CITY OF INDUSTRY**.

The contractor may, at his own expense, substitute securities for monies to be withheld to ensure performance under the contract.

By the order of the **CITY OF INDUSTRY** dated **April 24, 2025**

---

Julie Gutierrez-Robles, City Clerk

**ESTIMATE FOR:**

**CITY OF INDUSTRY**

**PROJECT NO. 439**

SAN JOSE AVENUE RECONSTRUCTION 500' WEST OF NOGALES STREET  
TO 400' WEST OF CHARLIE ROAD

**CONTRACT NO. CITY-1439**

**ENGINEER'S ESTIMATE  
\$5,397,000.00**

SECTION A

**CITY OF INDUSTRY  
PROJECT NO. 439**

SAN JOSE AVENUE RECONSTRUCTION 500' WEST OF NOGALES STREET TO  
400' WEST OF CHARLIE ROAD

CONTRACT NO. CITY-1439

The **CITY OF INDUSTRY**, hereinafter referred to as the **CITY**, will receive bids for the construction of the above project until **10:00 A.M. on Wednesday, June 4, 2025**, via the City of Industry's PlanetBids™ vendor portal. Bids are to be submitted through <https://www.planetbids.com/portal/portal.cfm?CompanyID=29042>.

Postmarks, mailed, emailed, or hard copy bids will not be accepted. Late bids will not be accepted.

It is the responsibility of the bidder to be sure the bid is submitted prior to the date and time indicated above. Free digital versions of the plans and specifications are available on the vendor portal. Hard copies are no longer available for purchase.

At the time of submission of the bid and thereafter, each bidder must be licensed as a **Class A - General Engineering** as defined in Sections 7055-7058 of the Business and Professions Code. Each bidder shall set forth on the Bidder's Information Sheet and the Contractor's License Affidavit the classification and number of the requisite license which that bidder holds.

The **CITY** reserves the right to award the contract to the contractor with another license class if the **CITY** determines that the license class is proper for the proposed work.

A contractor or subcontractor shall not be qualified to bid on, be listed in a bid proposal, subject to the requirements of Section 4104 of the Public Contract Code, or engage in the performance of any contract for public work, as defined in this chapter, unless currently registered and qualified to perform public work pursuant to Section 1725.5. **Please note:** *It is not a violation of this section for an unregistered contractor to submit a bid that is authorized by Section 7029.1 of the Business and Professions Code or by Section 10164 or 20103.5 of the Public Contract Code, provided the contractor is registered to perform public work pursuant to Section 1725.5 at the time the contract is awarded.* Any bids submitted without proof that bidder and any listed subcontractor(s) are currently registered and qualified to perform public work, pursuant to Labor Code Section 1725.5, may not be accepted by the CITY.

The Scope of Work is as follows: Removal of existing AC pavement section and reconstructing with new AC pavement on crushed aggregate base (CAB) with 2-layers of geogrid; removal of existing street light poles and foundations; installation of new street light system; removal of existing street trees and planting of new street trees; restoration of landscaping and irrigation; reconstruction and repair of PCC curb & gutters, sidewalks,

driveways, and curb ramps; installation of new power duct bank; and pavement markers, markings and striping.

Online Questions and Answers will be due via the City of Industry's PlanetBids™ vendor portal on **Friday, May 23, 2025 at 5:00 P.M.**

The bid shall be accompanied by a bid guarantee in the form of a Cashier's Check or Bidder's Bond for not less than ten percent (10%) of the total amount of the bid, payable to the **CITY OF INDUSTRY**. The bid guarantee is to insure that the bidder, if awarded the work, will enter into a contract with the CITY. Failure of a contractor to enter into a contract within ten (10) days following award will cause the bid guarantee to be forfeited. If the bid guarantee is a Cashier's Check it must be delivered to City Hall prior to the bid opening date and time. The Cashier's Check shall be sealed in an envelope, endorsed as follows: CITY-1439 - SAN JOSE AVENUE RECONSTRUCTION 500' WEST OF NOGALES STREET TO 400' WEST OF CHARLIE ROAD, City of Industry City Hall, 15625 Mayor Dave Way, City of Industry, California 91744. If a bid bond is chosen, a scanned PDF will be accepted through PlanetBids™, however, the three apparent low bidders will be contacted to submit the original bid bond and signed bid package to the CITY and will be given a deadline to submit.

The CITY may, upon refusal or failure of a successful responsible bidder to accept the contract, award it to the next lowest bidder. If the CITY awards the contract to the second lowest bidder, the amount of the lowest bidder's bid guarantee shall be applied by the CITY to the difference between the low bid and the second lowest bid; the surplus, if any, shall be returned to the lowest bidder if cash is used, or to the surety company if a bond is used.

The successful bidder will be required to furnish a labor and materials bond in an amount equal to one hundred percent (100%) of the contract price and a faithful performance bond in an amount equal to one hundred percent (100%) of the contract price. A maintenance bond equal to ten percent (10%) of the total bid price amount is to remain in force for one (1) year after the date of completion of work, shall be submitted prior to execution of contract. The above bonds shall be secured by a surety company satisfactory to the CITY, and licensed as a Surety Insurer in the State of California and rated at least B+:V in the latest "Best's Insurance Guide." The attached bond forms shall be used without exception.

## **CONTRACTOR**

### **INSURANCE**

Prior to the beginning of and throughout the duration of the Project, Contractor and its subcontractors shall maintain insurance in conformance with the requirements set forth below. Contractor will use existing coverage to comply with these requirements. If that existing coverage does not meet the requirements set forth herein, Contractor agrees to amend, supplement or endorse the existing coverage to do so.

Contractor acknowledges that the insurance coverage and policy limits set forth in this section constitute the minimum amount of coverage required. Any insurance proceeds

available to Contractor or its subcontractors in excess of the limits and coverage identified in this Agreement and which is applicable to a given loss, claim or demand, will be equally available to the CITY.

Contractor shall provide the following types and amounts of insurance:

Without limiting Contractor's indemnification of CITY, and prior to commencement of the Project, Contractor shall obtain, provide and maintain at its own expense during the term of this Agreement, policies of insurance of the type and amounts described below and in a form satisfactory to the CITY.

**General Liability Insurance.** Contractor shall maintain commercial general liability insurance with coverage at least as broad as Insurance Services Office form CG 00 01, in an amount not less than \$5,000,000 per occurrence, \$10,000,000 general aggregate, for bodily injury, personal injury, and property damage, and a \$5,000,000 completed operations aggregate. The policy must include contractual liability that has not been amended. Any endorsement restricting standard ISO "insured contract" language will not be accepted.

**Automobile Liability Insurance.** Contractor shall maintain automobile insurance at least as broad as Insurance Services Office form CA 00 01 covering bodily injury and property damage for all activities of the Contractor arising out of or in connection with work to be performed under this Agreement, including coverage for any owned, hired, non-owned or rented vehicles, in an amount not less than \$1,000,000 combined single limit for each accident.

**Umbrella or Excess CGL Insurance.** If the CONTRACTOR elects to include an umbrella or excess policy to cover any of the total limits required beyond the primary commercial general liability ("CGL") policy limits and/or the primary commercial automobile liability policy limits, then the policy must include the following:

- The umbrella or excess policy shall follow form over the CONTRACTOR's primary general liability coverage and shall provide a separate aggregate limit for products and completed operations coverage.
- The umbrella or excess policy shall not contain any restrictions or exclusions beyond what is contained in the primary policy.
- The umbrella or excess policy shall contain a clause stating that it takes effect (drops down) in the event the primary limits are impaired or exhausted.
- The umbrella or excess policy must also extend coverage over the automobile policy if it is to be used in combination with the primary automobile policy to meet the total insurance requirement limits.

**Workers' Compensation Insurance.** Contractor shall maintain Workers' Compensation Insurance (Statutory Limits) and Employer's Liability Insurance (with limits of at least \$1,000,000) for Contractor's employees in accordance with the laws of the State of California, Section 3700 of the Labor Code. In addition, Contractor shall require each subcontractor to similarly maintain Workers' Compensation Insurance and Employer's

Liability Insurance in accordance with the laws of the State of California, Section 3700 for all of the subcontractor's employees.

Contractor shall submit to the CITY, along with the certificate of insurance, a Waiver of Subrogation endorsement in favor of the CITY, its officers, agents, employees and volunteers.

**Pollution Liability Insurance.** Environmental Impairment Liability Insurance shall be written on a Contractor's Pollution Liability form or other form acceptable to the CITY providing coverage for liability arising out of sudden, accidental and gradual pollution and remediation. The policy limit shall be no less than \$1,000,000 dollars per claim and in the aggregate. All activities contemplated in this agreement shall be specifically scheduled on the policy as "covered operations." The policy shall provide coverage for the hauling of waste from the project site to the final disposal location, including non-owned disposal sites.

**Completed Operations Coverage.** Products/completed operations coverage shall extend a minimum of ten years after project completion. Coverage shall be included on behalf of the insured for covered claims arising out of the actions of independent contractors. If the insured is using subcontractors, the Policy must include work performed "by or on behalf" of the insured. Policy shall contain no language that would invalidate or remove the insurer's duty to defend or indemnify for claims or suits expressly excluded from coverage. Policy shall specifically provide for a duty to defend on the part of the insurer. The CITY, its officials, officers, agents, and employees, shall be included as insureds under the policy.

Other provisions or requirements:

**Proof of Insurance.** Contractor shall provide certificates of insurance to the CITY as evidence of the insurance coverage required herein, along with a waiver of subrogation endorsement for workers' compensation. Insurance certificates and endorsements must be approved by the CITY's risk manager prior to commencement of performance. Current certification of insurance shall be kept on file with the CITY at all times during the term of this contract. The CITY reserves the right to require complete, certified copies of all required insurance policies, at any time.

**Duration of Coverage.** Contractor shall procure and maintain for the duration of the contract insurance against claims for injuries to persons or damages to property, which may arise from or in connection with the performance of the work hereunder by Contractor, his agents, representatives, employees or subcontractors. Contractor must maintain general liability and umbrella or excess liability insurance for as long as there is a statutory exposure to completed operations claims. The CITY and its officers, officials, employees, and agents shall continue as additional insureds under such policies.

**Primary/Noncontributing.** Coverage provided by Contractor shall be primary and any insurance or self-insurance procured or maintained by the CITY shall not be required to contribute with it. The limits of insurance required herein may be satisfied by a combination of primary and umbrella or excess insurance. Any umbrella or excess

insurance shall contain or be endorsed to contain a provision that such coverage shall also apply on a primary and non-contributory basis for the benefit of the CITY before the CITY's own insurance or self-insurance shall be called upon to protect it as a named insured.

**CITY's Rights of Enforcement.** In the event any policy of insurance required under this Agreement does not comply with these requirements or is canceled and not replaced, the CITY has the right but not the duty to obtain the insurance it deems necessary and any premium paid by the CITY will be promptly reimbursed by Contractor or the CITY will withhold amounts sufficient to pay premium from Contractor payments. In the alternative, the CITY may cancel this Agreement.

**Acceptable Insurers.** All insurance policies shall be issued by an insurance company currently authorized by the Insurance Commissioner to transact business of insurance or is on the List of Approved Surplus Line Insurers in the State of California, with an assigned policyholders' Rating of A- (or higher) and Financial Size Category Class VII (or larger) in accordance with the latest edition of Best's Key Rating Guide, unless otherwise approved by the CITY's risk manager.

**Waiver of Subrogation.** All insurance coverage maintained or procured pursuant to this agreement shall be endorsed to waive subrogation against CITY, its elected or appointed officers, agents, officials, employees and volunteers or shall specifically allow Contractor or others providing insurance evidence in compliance with these specifications to waive their right of recovery prior to a loss. Contractor hereby waives its own right of recovery against CITY, and shall require similar written express waivers and insurance clauses from each of its subconsultants.

**Enforcement of Contract Provisions (non estoppel).** Contractor acknowledges and agrees that any actual or alleged failure on the part of the CITY to inform Contractor of non-compliance with any requirement imposes no additional obligations on the CITY nor does it waive any rights hereunder.

**Requirements Not Limiting.** Requirements of specific coverage features or limits contained in this Section are not intended as a limitation on coverage, limits or other requirements, or a waiver of any coverage normally provided by any insurance. Specific reference to a given coverage feature is for purposes of clarification only as it pertains to a given issue and is not intended by any party or insured to be all inclusive, or to the exclusion of other coverage, or a waiver of any type. If the Contractor maintains higher limits than the minimums shown above, the CITY requires and shall be entitled to coverage for the higher limits maintained by the Contractor. Any available insurance proceeds in excess of the specified minimum limits of insurance and coverage shall be available to the CITY.

**Notice of Cancellation.** Contractor agrees to oblige its insurance agent or broker and insurers to provide to CITY with a thirty (30) day notice of cancellation (except for nonpayment for which a ten (10) day notice is required) or nonrenewal of coverage for each required coverage.

**Additional Insured Status.** General liability policies shall provide or be endorsed to provide that CITY and its officers, officials, employees, agents, and volunteers shall be additional insureds under such policies. This provision shall also apply to any excess/umbrella liability policies.

**Prohibition of Undisclosed Coverage Limitations.** None of the coverages required herein will be in compliance with these requirements if they include any limiting endorsement of any kind that has not been first submitted to CITY and approved of in writing.

**Separation of Insureds.** A severability of interests provision must apply for all additional insureds ensuring that Contractor's insurance shall apply separately to each insured against whom claim is made or suit is brought, except with respect to the insurer's limits of liability. The policy(ies) shall not contain any cross-liability exclusions.

**Pass Through Clause.** Contractor agrees to ensure that its subconsultants, subcontractors, and any other party involved with the project who is brought onto or involved in the project by Contractor, provide the same minimum insurance coverage and endorsements required of Contractor. Contractor agrees to monitor and review all such coverage and assumes all responsibility for ensuring that such coverage is provided in conformity with the requirements of this section. Contractor agrees that upon request, all agreements with consultants, subcontractors, and others engaged in the project will be submitted to CITY for review.

**CITY's Right to Revise Requirements.** The CITY reserves the right at any time during the term of the contract to change the amounts and types of insurance required by giving the Contractor a ninety (90)-day advance written notice of such change. If such change results in substantial additional cost to the Contractor, the CITY and Contractor may renegotiate Contractor's compensation.

**Self-insured Retentions.** Any self-insured retentions must be declared to and approved by CITY. CITY reserves the right to require that self-insured retentions be eliminated, lowered, or replaced by a deductible. Self-insurance will not be considered to comply with these specifications unless approved by the CITY.

**Timely Notice of Claims.** Contractor shall give CITY prompt and timely notice of claims made or suits instituted that arise out of or result from Contractor's performance under this Agreement, and that involve or may involve coverage under any of the required liability policies.

**Additional Insurance.** Contractor shall also procure and maintain, at its own cost and expense, any additional kinds of insurance, which in its own judgment may be necessary for its proper protection and prosecution of the work.

## EXPERIENCE AND SAFETY

The successful bidder may be required to submit a statement attesting to its financial responsibility, technical ability, experience, and safety record.

## PREVAILING WAGES

- A. Wage rates for this Project shall be in accordance with the "General Wage Determination Made by the Director of Industrial Relations Pursuant To California Labor Code, Part 7, Chapter 1, Article 2, Sections 1770, 1773 and 1773.1 ", for Los Angeles County. Wage rates shall conform to those on file at City Hall and the Project site.
- B. The following Labor Code sections are hereby referenced and made a part of this Agreement:
  - (i) Section 1775, Penalty for Failure to Comply with Prevailing Wage Rates.
  - (ii) Section 1777.4, Apprenticeship Requirements.
  - (iii) Section 1777.5, Apprenticeship Requirements.
  - (iv) Section 1813, Penalty for Failure to Pay Overtime.
  - (v) Section 1810 and 1811, Working Hour Restrictions.
  - (vi) Section 1775, Payroll Records.
  - (vii) Section 1773.8, Travel and Subsistence Pay.

## CONTRACTOR REGISTRATION PROGRAM

A contractor or subcontractor shall not be qualified to bid on, be listed in a bid proposal, subject to the requirements of Section 4104 of the Public Contract Code, or engage in the performance of any contract for public work, as defined in this chapter, unless currently registered and qualified to perform public work pursuant to Section 1725.5. **Please note:** *It is not a violation of this section for an unregistered contractor to submit a bid that is authorized by Section 7029.1 of the Business and Professions Code or by Section 10164 or 20103.5 of the Public Contract Code, provided the contractor is registered to perform public work pursuant to Section 1725.5 at the time the contract is awarded.* Any bids submitted without proof that bidder and any listed subcontractor(s) are currently registered and qualified to perform public work, pursuant to Labor Code Section 1725.5, may not be accepted by the CITY.

## LABOR COMPLIANCE MONITORING AND ENFORCEMENT

The project is subject to compliance monitoring and enforcement by the Department of Industrial Relations (California Labor Code Section 1771.4).

## AGREEMENT

When the award of a contract is made to a corporation, the Agreement must be signed by the Secretary/Treasurer of the corporation in addition to the signature of the President/Vice President, or the public agency needs to receive a copy of a resolution adopted by the Board of Directors of the corporation indicating that the party executing the contract has the authority to bind the corporation.

## SURETY BONDS

All surety bonds issued in connection with projects for public works must be accompanied by a power of attorney from the surety company authorizing the person executing the bond to sign on behalf of the company. The power of attorney and the bonds must be executed by the same person, and such signatures shall be notarized.

By the order of the **CITY OF INDUSTRY** dated **April 24, 2025**.

---

Julie Gutierrez-Robles, City Clerk

# CITY OF INDUSTRY IMPROVEMENT PROJECT NO. 439 SAN JOSE AVENUE RECONSTRUCTION CONTRACT NO. CITY-1439

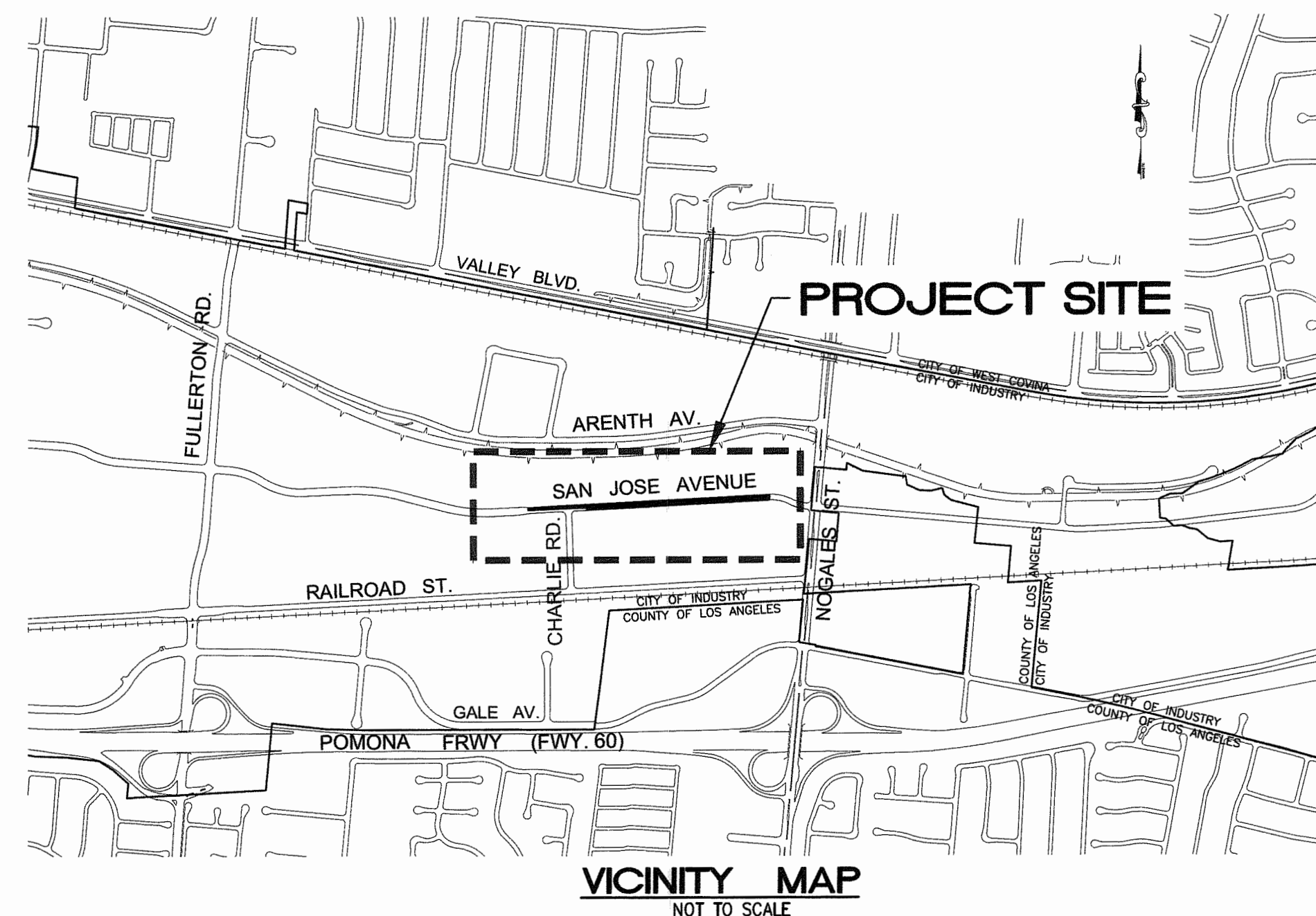

SHEET INDEX		
CONTRACT DWG NO.	SHEET NO.	DESCRIPTION
1	1	CONTRACT TITLE SHEET
2	2	STREET IMPROVEMENT PLAN TITLE SHET
3	3	NOTES
4	4	TYPICAL SECTIONS & DETAILS, 1 OF 2
5	5	TYPICAL SECTIONS & DETAILS, 2 OF 2
6	6	PLAN AND PROFILE, STA 19+50.00 TO STA 24+31.81
7	7	PLAN AND PROFILE, STA 14+00.00 TO STA 19+50.00
8	8	PLAN AND PROFILE, STA 8+50.00 TO STA 14+00.00
9	9	PLAN AND PROFILE, STA 4+70.07 TO STA 8+50.00
10	1	SIGNING & STRIPING PLAN
11	2	STREET LIGHTING PLAN AND TITLE SHEET
12	3	STREET LIGHTING PLAN
13	4	STREET LIGHTING PLAN DETAILS & GENERAL NOTES
14	1	SCE SERVICE DETAIL AND WIRING DIAGRAM
15	2	LANDSCAPE PLANS COVER SHEET
16	3	IRRIGATION PLAN, 1 OF 2
17	4	IRRIGATION PLAN, 2 OF 2
18	5	IRRIGATION LEGEND & NOTES
19	6	PLANTING PLAN, 1 OF 2
20	7	PLANTING PLAN, 2 OF 2
21	8	PLANTING LEGEND AND NOTES
22	9	EXISTING TREE PLAN, 1 OF 2
23	10	EXISTING TREE PLAN, 2 OF 2
24	11	HYDROZONE MAP
25	12	LANDSCAPE DETAILS
26	13	LANDSCAPE SPECIFICATIONS, 1 OF 3
27	14	LANDSCAPE SPECIFICATIONS, 2 OF 3
28	15	LANDSCAPE SPECIFICATIONS, 3 OF 3

K:\CITY-C-1439\_San\_Jose\_Reconstruction\_From\_Charlie\_Rd\_to\_Noelde\_S\Engineering\Sheets\1439-CEC\01.dwg 5/12/2022 12:02 PM

**BENCHMARK**  
B.M. CH-1 ELEV. 428.357 FT.  
1-3/8" BRASS CAP MONUMENT ON TOP OF WEST CURB CHARLIE ROAD 60' ± NORTH OF RAILROAD ST (2' ± NORTH OF BCR)



NO.	DATE	REVISIONS	CK. BY

**CITY OF INDUSTRY**

INCORPORATED JUNE 18, 1957  
P.O. Box 3366, City of Industry, California 91744  
Administrative Offices: 15625 Mayor Dave Way  
(626) 333-2211

Prepared by:

**ACNC**  
ENGINEERING

255 N Hacienda Blvd | Ste 222  
City of Industry | CA | 91744  
P | 626.333.0336  
www.cnc-eng.com

*James R. Gramsie*  
JAMES R. GRAMSIE, P.E. 059785

05/12/2022  
DATE

**CITY OF INDUSTRY**

APPROVED BY: \_\_\_\_\_

CLEMENT N. CALUJLO, PE, RCE 27743 DEPUTY CITY ENGINEER DATE: \_\_\_\_\_ JOSHUA L. NELSON, PE, RCE 66959 CITY MANAGER DATE: \_\_\_\_\_

**SAN JOSE AVENUE RECONSTRUCTION**

**STREET IMPROVEMENTS  
SAN JOSE AVENUE  
CONTRACT TITLE SHEET**

DESIGNED BY: A.L. CHECKED BY: J.C. | JOB NO. MP08-09  
DRAFTED BY: R.L.I. DATE: MAY 2022 | CONTRACT NO. CITY-1439

SHEET **1** OF 28

CONTRACT DRAWING 1 OF 28

# CITY OF INDUSTRY IMPROVEMENT PROJECT NO. 439 SAN JOSE AVENUE RECONSTRUCTION CONTRACT NO. CITY-1439 STREET IMPROVEMENT PLAN

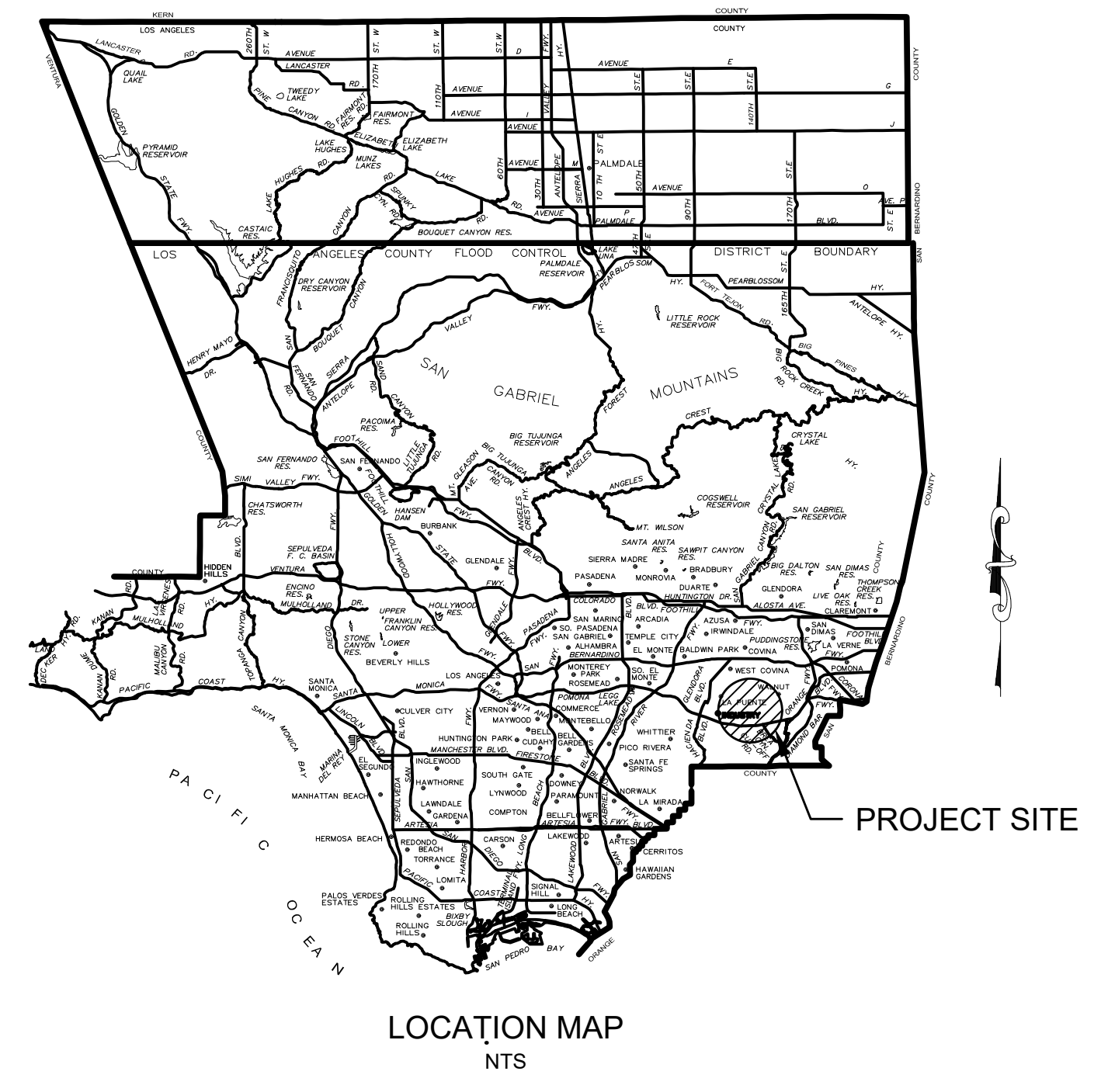

**SHEET INDEX**

SHEET NO.	DESCRIPTION
1	TITLE SHEET
2	NOTES
3	TYPICAL SECTIONS & DETAILS, 1 OF 2
4	TYPICAL SECTIONS & DETAILS, 2 OF 2
5	PLAN & PROFILE, STA 19+50.00 TO STA 24+31.81
6	PLAN & PROFILE, STA 14+00.00 TO STA 19+50.00
7	PLAN & PROFILE, STA 8+50.00 TO STA 14+00.00
8	PLAN & PROFILE, STA 4+70.07 TO STA 8+50.00
9	SIGNING & STRIPING PLAN

**LEGEND AND ABBREVIATIONS:**

AC	ASPHALT CONCRETE	RWD	ROWLAND WATER DISTRICT
BC	BEGIN CURVE	SCE	SOUTHERN CALIFORNIA EDISON
BCR	BEGIN OF CURB RETURN	SPWP	STANDARD PLANS FOR PUBLIC WORK CONSTRUCTION
BDRY	BOUNDARY	STA	STATION
BVC	BEGINNING OF VERTICAL CURVE	STD	STANDARD
BW	BACK OF WALK	TC	TOP OF CURB
BX	BOTTOM OF DRIVEWAY CURB	TG	TOP OF GRATE
CAB	CRUSHED AGGREGATE BASE	TRANS	TRANSITION
CB	CATCH BASIN	TSP	TRAFFIC SIGNAL POLE
C&G	CURB AND GUTTER	TX	TOP OF DRIVEWAY CURB
CIWS	CITY OF INDUSTRY WATER WORKS SYSTEM	TYP	TYPICAL
CL	CENTER LINE	VAR	VARIES
CLF	CHAIN LINK FENCE	WI	WROUGHT IRON
CONC	CONCRETE		
CPUC	CALIFORNIA PUBLIC UTILITIES COMMISSION	Ⓢ	EXIST POWER POLE
CSG	CASING	Ⓢ	EXIST GUY WIRE
DWY	DRIVEWAY	Ⓢ	EXIST PULL BOX
EC	END CURB	Ⓢ	EXIST CATCH BASIN
ECR	END OF CURB RETURN	Ⓢ	EXIST FIRE HYDRANT
EVC	END OF VERTICAL CURVE	Ⓢ	EXIST WATER VALVE
EG	EDGE OF GUTTER	Ⓢ	EXIST TELEPHONE MANHOLE
ES	EXISTING SURFACE	Ⓢ	EXIST SEWER MANHOLE
EX	EXISTING	Ⓢ	EXIST DRAIN MANHOLE
EXO	EXCAVATION	Ⓢ	EXIST MONITORING WELL
FG	FINISHED GRADE	Ⓢ	EXIST DRIVEWAY
FH	FIRE HYDRANT	Ⓢ	EXIST CURB AND GUTTER
FL	FLOW LINE	Ⓢ	EXIST SIGN
FS	FINISHED SURFACE	Ⓢ	STREET RW
ICV	IRRIGATION CHECK VALVE	Ⓢ	EXIST STREET LIGHT
LIP	LIP OF GUTTER	Ⓢ	EXIST TREE
LP	LOW POINT	Ⓢ	EXIST GAS LINE
LT	LEFT	Ⓢ	EXIST SANITARY SEWER LINE
MH	MANHOLE	Ⓢ	EXIST WATER LINE
MIN	MINIMUM	Ⓢ	EXIST STORM DRAIN LINE
MOC	MIDDLE OF CURVE	Ⓢ	EXIST TELEPHONE LINE
OC	ON CENTER	Ⓢ	EXIST CHAIN LINK FENCE
PCC	PORTLAND CEMENT CONCRETE	Ⓢ	PROPOSED DRIVEWAY
POC	POINT ON CURB	Ⓢ	PROPOSED PROPERTY ACQUISITION
PRC	POINT OF REVERSE CURVE	Ⓢ	PROPOSED STREET LIGHT
PT	POINT	Ⓢ	PROPOSED STREET LIGHT CONDUIT
PVMT	PAVEMENT		
RCP	REINFORCED CONCRETE PIPE		
RT	RIGHT		
RW	RIGHT OF WAY		

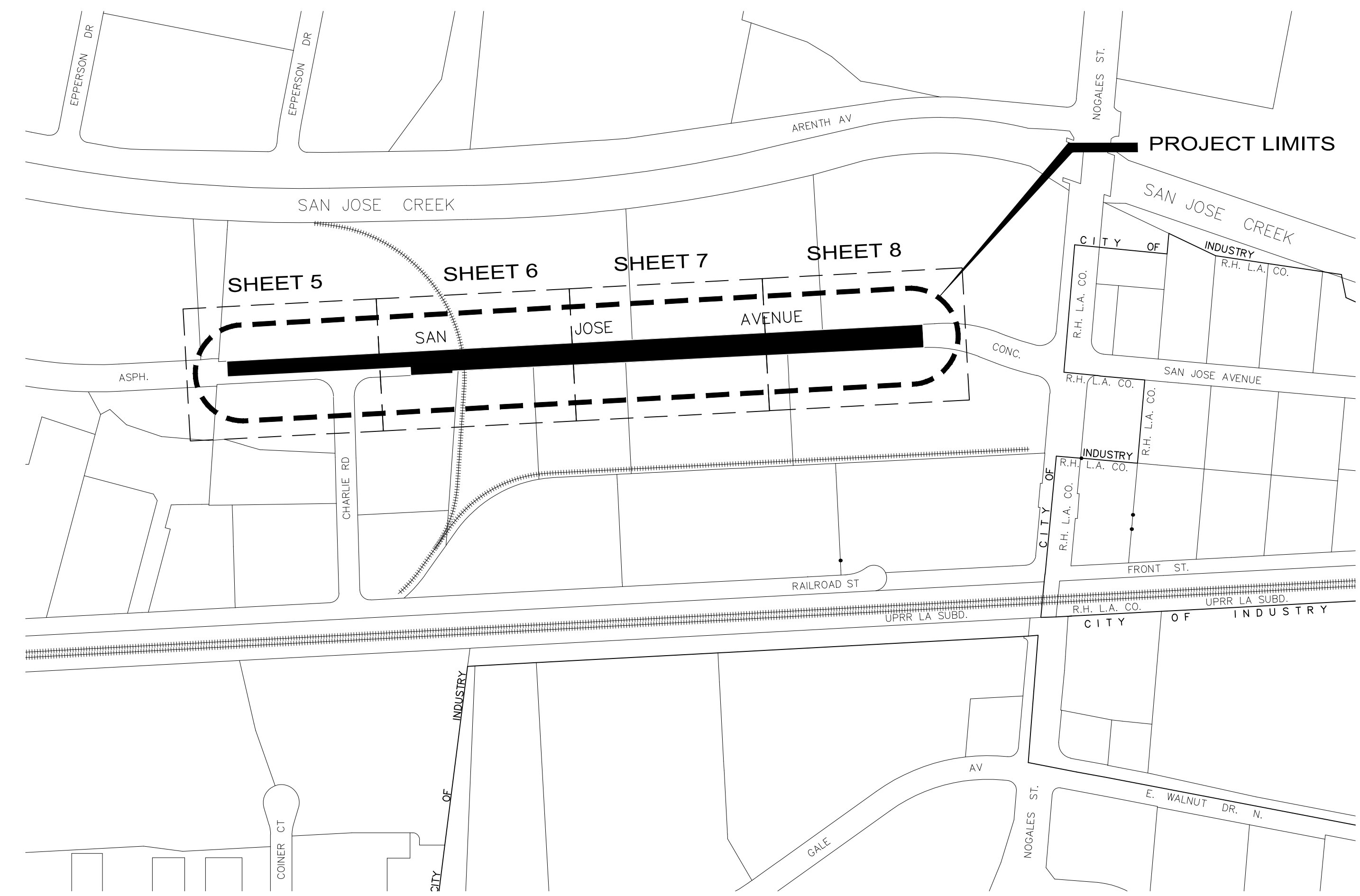

**LIST OF STANDARDS**

SPPWC 2012 EDITION

SPPWC STD. PLAN NO. 110-2 B	DRIVEWAY APPROACH
SPPWC STD. PLAN NO. 115-5	YELLOW TRUNCATED DOMES
SPPWC STD. PLAN NO. 140-3	MEDIAN TAPER
SPPWC STD. PLAN NO. 205-2	MANHOLE ADJUSTMENT
SPPWC STD. PLAN NO. 523-2	ROOT PRUNING
SPPWC STD. PLAN NO. 606-4	TYPE B METAL HAND RAIL
SPPWC STD. PLAN NO. 618-3	MASONRY RETAINING WALL

CITY OF INDUSTRY STANDARD PLANS

COI STD. PLAN NO. 112	CURB AND GUTTER
COI STD. PLAN NO. 114	DRIVEWAY APPROACH
COI STD. PLAN NO. 115	PCC SIDEWALK
COI STD. PLAN NO. 212	CATCH BASIN LOCAL DEPRESSION
COI STD. PLAN NO. 213	PARKWAY DRAIN NO. 1
COI STD. PLAN NO. 214	PARKWAY DRAIN NO. 2

STATE OF CALIFORNIA 2015 EDITION

CALTRANS STD. PLAN NO. A20A, A20B, & A20D	STRIPING
CALTRANS STD. PLAN NO. A24A, A24B, & A24E	STRIPING

P:\2016\2016.0100.0001.47 Industry - San Jose Avenue Reconstruction Proj. No. CITY-1439\Cadd\Sheets\1610001.47 - 01 TITLE.dwg  
5/12/2022 10:55 AM

**BENCHMARK**  
B.M. CH-1 ELEV. 428.357 FT.  
1-3/8" BRASS CAP MONUMENT ON TOP OF WEST CURB CHARLIE ROAD 60'± NORTH OF RAILROAD ST. (2'± NORTH OF BCR)  
INDUSTRY, CA

NO.	DATE	REVISIONS	OK BY



**CITY OF INDUSTRY**  
INCORPORATED JUNE 18, 1957  
P.O. Box 3366, City of Industry, California 91744  
Administrative Offices: 15625 Mayor Dave Way  
(626) 333-2211

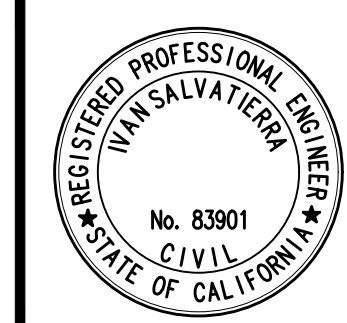

Plans Prepared by:  
**JMD**  
PLANNING | ENGINEERING | MANAGEMENT  
18645 East Gale Avenue, Suite 212  
City of Industry, CA 91748  
(626) 800-1137 Tel  
(626) 800-1138 Fax  
www.jmdaz.com  
UNDER THE SUPERVISION OF:  
IVAN SALVATIERRA RCE 83901 DATE: 5/12/2022

**CITY OF INDUSTRY**

APPROVED BY: \_\_\_\_\_  
CLEMENT N. CALVILLO, PE, RCE 27743 DEPUTY CITY ENGINEER DATE: \_\_\_\_\_ JOSHUA L. NELSON, PE, RCE 66959 CITY MANAGER DATE: \_\_\_\_\_

**SAN JOSE AVENUE RECONSTRUCTION**

**STREET IMPROVEMENTS**  
**SAN JOSE AVENUE**  
**TITLE SHEET**

DESIGNED BY: D.D	CHECKED BY: D.S	JOB NO. MP08-09	SHEET 1 OF 9
DRAFTED BY: D.H	DATE: 09/15/2021	CONTRACT NO. CITY-1439	

CONTRACT DRAWING OF

**GENERAL NOTES**

- GENERAL NOTES APPLY TO ALL PLANS.
- PRIME CONTRACTOR LICENSE REQUIRED CLASS A.
- ALL PROPOSED WORK SHALL BE CONSTRUCTED PER SPPWC STANDARD PLANS AND SPECIFICATIONS UNLESS OTHERWISE SHOWN.
- PRIOR TO BEGINNING ANY WORK, THE CONTRACTOR SHALL OBTAIN A PERMIT FROM THE CITY OF INDUSTRY ENGINEERING OFFICE, 15625 MAYOR DAVE WAY #100, CITY OF INDUSTRY, CA 91744, (626) 333-2211.
- ALL WORK COVERED BY THIS PLAN SHALL BE INSPECTED BY THE CITY ENGINEER. REQUEST FOR INSPECTION SERVICE SHALL BE MADE 48-HOURS IN ADVANCE AT (626) 333-0336.
- STREET IMPROVEMENT CONSTRUCTION SHALL BE DONE ACCORDING TO THE STANDARD PLANS OF THE CITY OF INDUSTRY, AVAILABLE AT THE ENGINEERING OFFICE OF THE CITY ENGINEER AT 15625 MAYOR DAVE WAY #100, CITY OF INDUSTRY, CA 91744, (626) 333-2211.
- WORK IN EXISTING STREETS SHALL BE COMPLETED AS SOON AS POSSIBLE TO MINIMIZE INCONVENIENCE TO ADJACENT PROPERTY OWNERS AND THE TRAVELING PUBLIC. FAILURE TO COMPLY WITH THIS REQUIREMENT IS A VIOLATION OF CITY ORDINANCE.
- THE CONTRACTOR SHALL NOTIFY THE LOS ANGELES COUNTY FIRE DEPARTMENT (818) 963-2417 AND THE LOS ANGELES SHERIFF DEPARTMENT (626) 330-3322 AT THE CITY OF INDUSTRY SUBSTATION AT LEAST 48-HOURS PRIOR TO START OF WORK.
- THE CONTRACTOR SHALL CALL UNDERGROUND SERVICE ALERT AT 1 (800) 422-4133 AND OBTAIN AN INQUIRY IDENTIFICATION NUMBER 48-HOURS PRIOR TO ANY STREET WORK.
- THE OPTION OF USING SLAG OR CRUSHED MISCELLANEOUS BASE (CMB) IN LIEU OF CRUSHED AGGREGATE BASE FOR ANY STREET IMPROVEMENT IS NOT ALLOWED. "CLASS 2 AGGREGATE BASE" MEETING THE GRADING AND QUALITY REQUIREMENTS OF CALTRANS STANDARD SPECIFICATION SECTION 26-1.02B, AND INSTALLED PER CALTRANS STANDARD SPECIFICATION SECTION 26-1.03 MAY BE USED IN LIEU OF CRUSHED AGGREGATE BASE.
- EXISTING CONCRETE IMPROVEMENTS AND ASPHALT CONCRETE PAVEMENT SHALL BE SAW CUT, FULL DEPTH, TO A TRUE LINE WHERE NEW CONCRETE OR ASPHALT IS TO JOIN.
- THE CONTRACTOR SHALL PROTECT ALL UTILITIES ENCOUNTERED DURING THIS PROJECT AND SHALL NOTIFY THE CITY ENGINEER AND/OR HIS REPRESENTATIVE IMMEDIATELY OF ANY UNDOCUMENTED SUBSTRUCTURES. ANY DAMAGE TO UTILITIES AS A RESULT OF CONTRACTOR'S ACTION SHALL BE REPAIRED AT THE CONTRACTOR'S SOLE EXPENSE TO THE SATISFACTION OF THE AGENCY HAVING JURISDICTION.
- ALL MANHOLES SHALL BE ADJUSTED TO FINISHED GRADE IN ACCORDANCE WITH SECTION 301-1.6 OF THE STANDARD SPECIFICATIONS FOR PUBLIC WORKS CONSTRUCTION.
- THE CONTRACTOR SHALL PROTECT AND RESTORE EXISTING UTILITIES AND IMPROVEMENTS AS PER SECTION 5-1, 5-2, AND 7-9 OF THE STANDARD SPECIFICATIONS FOR PUBLIC WORKS CONSTRUCTION.
- CONTRACTORS SHALL OBTAIN AND PAY FOR ALL REQUIRED TEMPORARY AND PERMANENT PERMITS, INCLUDING LICENSES, CERTIFICATES, INSPECTIONS, TESTS, AND SERVICES. COPIES OF APPLICABLE PERMITS AND AN APPROVED SET OF PLANS MUST BE AT THE JOB SITE AT ALL TIMES.
- CONTRACTOR SHALL COORDINATE CONSTRUCTION WITH ALL UTILITIES.
- THE FOLLOWING IS A LIST OF THE UTILITY COMPANIES AND THE PERSONS TO CONTACT REGARDING THE RESPECTIVE UTILITIES WITHIN THE LIMITS OF THIS PROJECT:

JOHN POEHLER ROWLAND WATER DISTRICT	(562) 697-1726
ANTHONY HOWARD SANITATION DISTRICTS OF LOS ANGELES	(562) 908-4288
DON BECKERMANN FRONTIER COMMUNICATIONS	(626) 666-3526
JAMES BOLLIER FRONTIER COMMUNICATIONS	(909) 469-6369
ROSALYN SQUIRES SOUTHERN CALIFORNIA GAS COMPANY (TRANSMISSION)	(213) 244-2669
MICHAEL CAVARRUBIAS SOUTHERN CALIFORNIA GAS COMPANY (DISTRIBUTION)	(714) 634-7260
MICHAEL BYRD SOUTHERN CALIFORNIA EDISON (CITY OF INDUSTRY)	(909) 592-3725
CROWN CASTLE	(877) 486-9377

- ANY CONTRACTOR OR SUBCONTRACTOR PERFORMING WORK ON THIS PROJECT SHALL BECOME FAMILIAR WITH THE SITE AND SHALL BE SOLELY RESPONSIBLE FOR ANY DAMAGE TO EXISTING FACILITIES RESULTING DIRECTLY OR INDIRECTLY FROM HIS OR HER OPERATIONS, WHETHER OR NOT SUCH FACILITIES ARE SHOWN ON THESE PLANS.
- THE WORK AREA SHALL BE CLEANED DAILY AND KEPT CLEAN FROM ALL DUST, DIRT AND DEBRIS.
- CONTRACTOR AS PRACTICABLE, SHALL BE RESPONSIBLE FOR IMPLEMENTING AND MAINTAINING WORK AREA BMPs.

**CONSTRUCTION NOTES**

- PROTECT IN PLACE.
- REMOVE ITEM PER PLAN.
- REMOVE AND HAUL EXISTING AC PAVEMENT INCLUDING BASE 20" DEEP.
- CONSTRUCT 13-1/2" CAB OVER 12" ENGINEERED FILL, INSTALL TWO LAYERS OF GEOGRID (TENSAR TX7-ONE), ONE LAYER AT BOTTOM OF CAB AND ONE LAYER AT 8" ABOVE SUBGRADE.
- CONSTRUCT 4" THICK ASPHALT BASE COURSE (PG-64-10-B).
- CONSTRUCT 2-1/2" THICK ASPHALT PAVEMENT SURFACE COURSE (PG 64-10-C).
- CONSTRUCT 4" THICK ASPHALT AC PAVEMENT (PG-64-10-B) OVER 6" CAB AT THE BACK OF PROPOSED DRIVEWAY.
- CONSTRUCT CURB AND GUTTER PER CITY OF INDUSTRY STD. PLAN NO. 112, TYPE PER PLAN, INCLUDING CRUSHED AGG. BASE.
- CONSTRUCT DRIVEWAY PER CITY OF INDUSTRY STD. PLAN NO. 114, INCLUDING CRUSHED AGG. BASE. WIDTH(W) PER PLAN.
- CONSTRUCT PCC SIDEWALK PER CITY OF INDUSTRY STD. PLAN NO. 115, INCLUDING CRUSHED AGG. BASE.
- CONSTRUCT CATCH BASIN LOCAL DEPRESSION PER CITY OF INDUSTRY STD. PLAN NO. 212.
- REMOVE AND RECONSTRUCT PARKWAY DRAIN NO. 1 PER CITY OF INDUSTRY STD. PLAN NO. 213.
- CONSTRUCT PARKWAY DRAIN NO. 2 PER CITY OF INDUSTRY STD. PLAN NO. 214, NO. OF PIPES PER PLAN.
- CONSTRUCT MODIFIED DRIVEWAY APPROACH PER SPPWC STD. PLAN NO. 110-2, TYPE B, AND PER DETAIL "A" ON SHEET NO. 3, INCLUDING CRUSHED AGG. BASE. WIDTH(W), WING(X), AND THICKNESS(I) PER PLAN.
- INSTALL YELLOW SURFACE MOUNTED TRUNCATED DOME MAT PER SPPWC STD. PLAN NO. 115-5.
- ADJUST MANHOLE FRAME AND COVER TO GRADE PER SPPWC STD. PLAN NO. 205-2.
- CONSTRUCT TYPE B METAL HAND RAIL PER SPPWC STD. PLAN NO. 606-4.
- CONSTRUCT 4' HIGH MASONRY RETAINING WALL PER SPPWC STD. PLAN NO. 618-3, TYPE PER PLAN. (145 LF)
- CONSTRUCT PCC RETAINING CURB PER DETAIL "D" ON SHEET NO. 3
- WATER STRUCTURE/FIRE HYDRANT/AIR VENTS/WATER METERS BOXES TO BE ADJUSTED/REMOVED/RELOCATED/INSTALLED BY ROWLAND WATER DISTRICT.
- EXISTING SCE ELECTRICAL MANHOLE/AULT/PULL BOX/STRUCTURES TO BE ADJUSTED/RELOCATED TO GRADE BY SCE.
- RELOCATE AND ADJUST GTE MANHOLE TO GRADE.
- CONSTRUCT CATCH BASIN WITH GRADING PER DETAIL F.
- NOT USED
- PROPOSED STREET LIGHT. SEE STREET LIGHT PLANS.
- REMOVE EXISTING TREE. SEE LANDSCAPE PLANS
- NOT USED
- INSTALL REMOVABLE CURB FACE PLATE COVER PER DETAIL "E" ON SHEET NO. 3.
- NOT USED
- REFURBISH LANDSCAPE AND IRRIGATION SYSTEM, INCLUDING RELOCATION OF VALVES AND IRRIGATION LINES.
- INSTALL NEW TREE PER SPECIFICATIONS.
- NOT USED

**SIGNING AND STRIPING NOTES**

- PROTECT EXISTING STRIPING/LEGEND IN PLACE.
- REMOVE STRIPING AND MARKING BY WET SANDBLASTING.
- INSTALL 6-INCH WHITE LANE LINE PER CALTRANS STD. PLAN NO. A20A, DETAIL 9.
- INSTALL 6-INCH DOUBLE YELLOW PER CALTRANS STD. PLAN NO. A20A, DETAIL 22.
- INSTALL 6-INCH WHITE EDGELINE PER CALTRANS STD. PLAN NO. A20B, DETAIL 27B.
- INSTALL 6-INCH DOUBLE YELLOW MEDIAN ISLAND PER CALTRANS STD. PLAN NO. A20B, DETAIL 29.
- INSTALL TWO-WAY LEFT TURN LANE PER CALTRANS STD. PLAN NO. A20B, DETAIL 32.
- INSTALL 8-INCH SOLID WHITE CHANNELIZING LINE PER CALTRANS STD. PLAN NO. A20D, DETAIL 38.
- INSTALL PAVEMENT MARKING ARROWS PER CALTRANS REVISED STD. PLAN NO. A24A, TYPE PER PLAN.
- INSTALL PAVEMENT LEGEND PER CALTRANS STD. PLAN NO. A24B.
- INSTALL 24-INCH WIDE SOLID WHITE LIMIT LINE SET 15-FEET FROM RAILROAD CANTILEVER CENTER OF POLE.
- INSTALL 12-INCH YELLOW DIAGONAL LINE.
- INSTALL W10-1 SIGN AND POST.
- PAINT CURB "RED". (LENGTH AS INDICATED)
- INSTALL 12-INCH WHITE LINE.
- INSTALL SURFACE MOUNTED WHITE CHANNELIZER WITH WHITE RETROREFLECTIVE SHEETING PER CALTRANS STD. PLAN NO. A73C AS SHOWN ON PLAN.
- REMOVE EXISTING SIGN AND POST

P:\2016\2016.0100.0001.47 Industry - San Jose Avenue Reconstruction Proj. No. CITY-1439\Cadd\Sheets\1610001.47 - 02 NOTES.dwg 5/12/2022 10:57 AM

100% SUBMITTAL  
BID SET

NO.	DATE	REVISIONS	OK BY



**CITY OF INDUSTRY**

INCORPORATED JUNE 18, 1957  
P.O. Box 3366, City of Industry, California 91744  
Administrative Offices: 15625 Mayor Dave Way  
(626) 333-2211

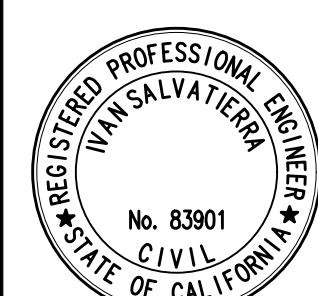

Plans Prepared by:



18645 East Gate Avenue, Suite 212  
City of Industry, CA 91748  
(626) 800-1137 Tel  
(626) 800-1138 Fax  
www.jmda.com

- Civil
- Highways
- Land Development
- Rail
- Structures
- Traffic
- Transportation

5/12/2022  
DATE

<b>CITY OF INDUSTRY</b>			
CLEMENT N. CALVILLO, PE, RCE 27743		DEPUTY CITY ENGINEER	
DATE			
<b>SAN JOSE AVENUE RECONSTRUCTION</b>			
<b>STREET IMPROVEMENTS SAN JOSE AVENUE NOTES</b>			
DESIGNED BY: D.D	CHECKED BY: D.S	JOB NO. MP08-09	SHEET 2 OF 9
DRAFTED BY: D.H	DATE: 09/15/2021	CONTRACT NO. CITY-1439	
CONTRACT DRAWING OF			

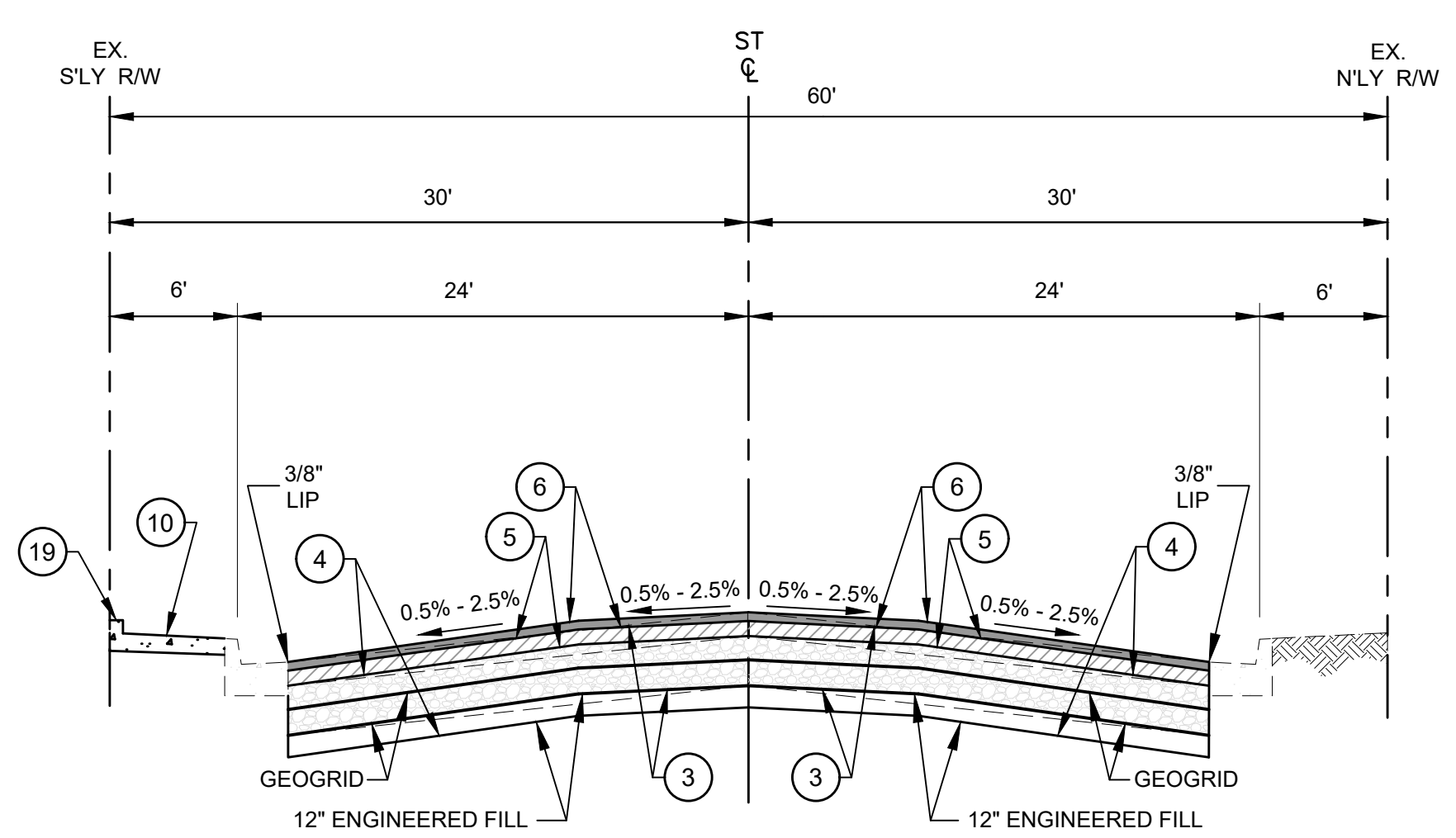

**TYPICAL SECTION**  
N.T.S.  
FROM STA. 4+70.07 TO STA. 17+75.67

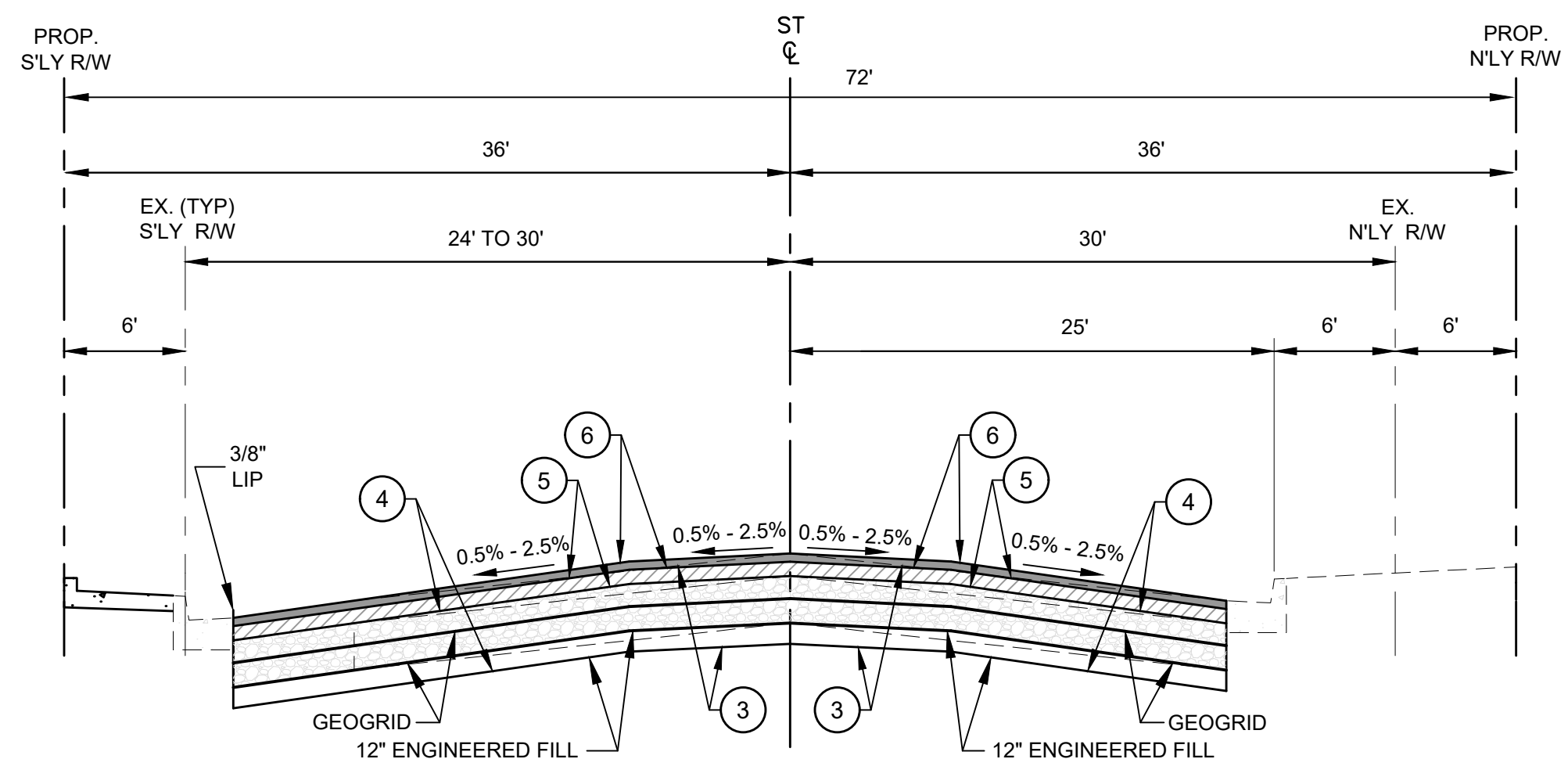

**TYPICAL SECTION**  
N.T.S.  
FROM STA. 17+75.67 TO STA. 17+94.43

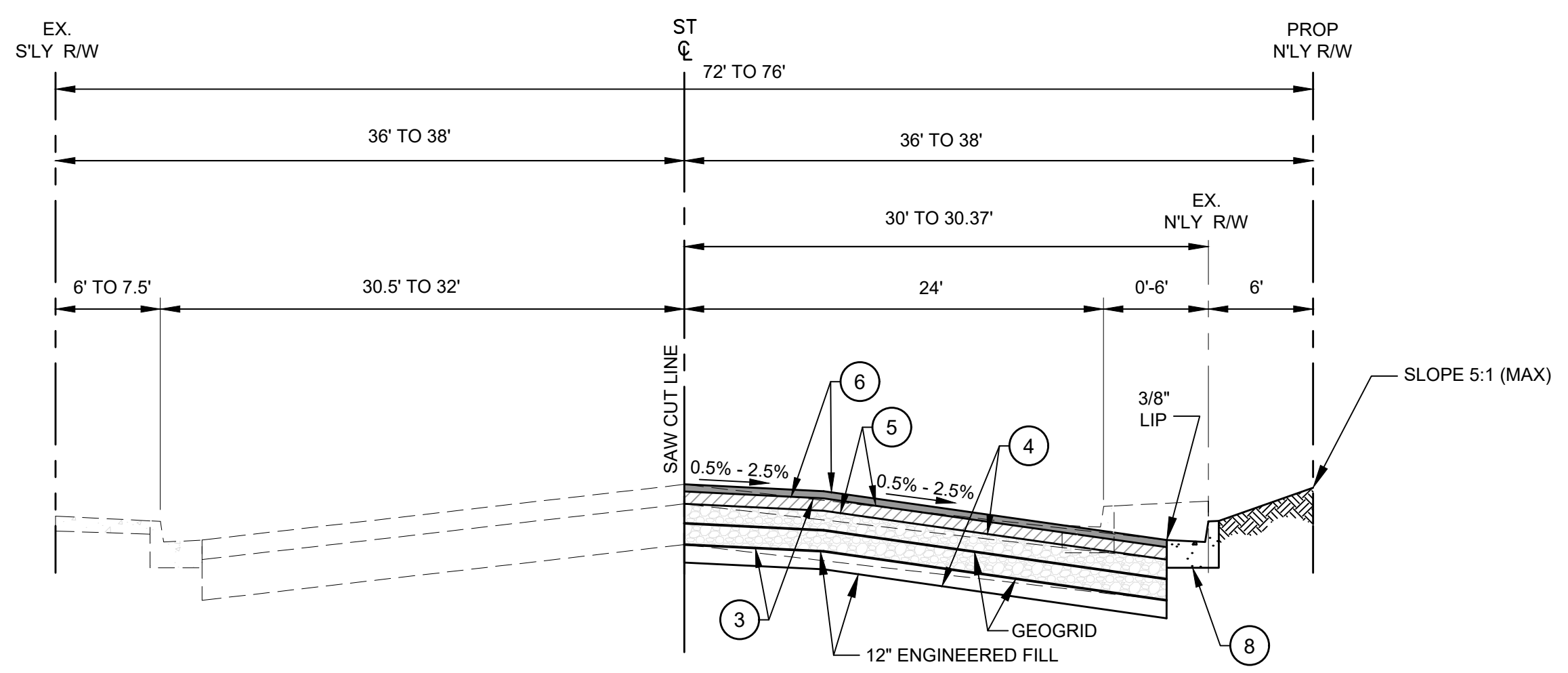

**TYPICAL SECTION**  
N.T.S.  
FROM STA. 17+94.43 TO STA. 24+31.81

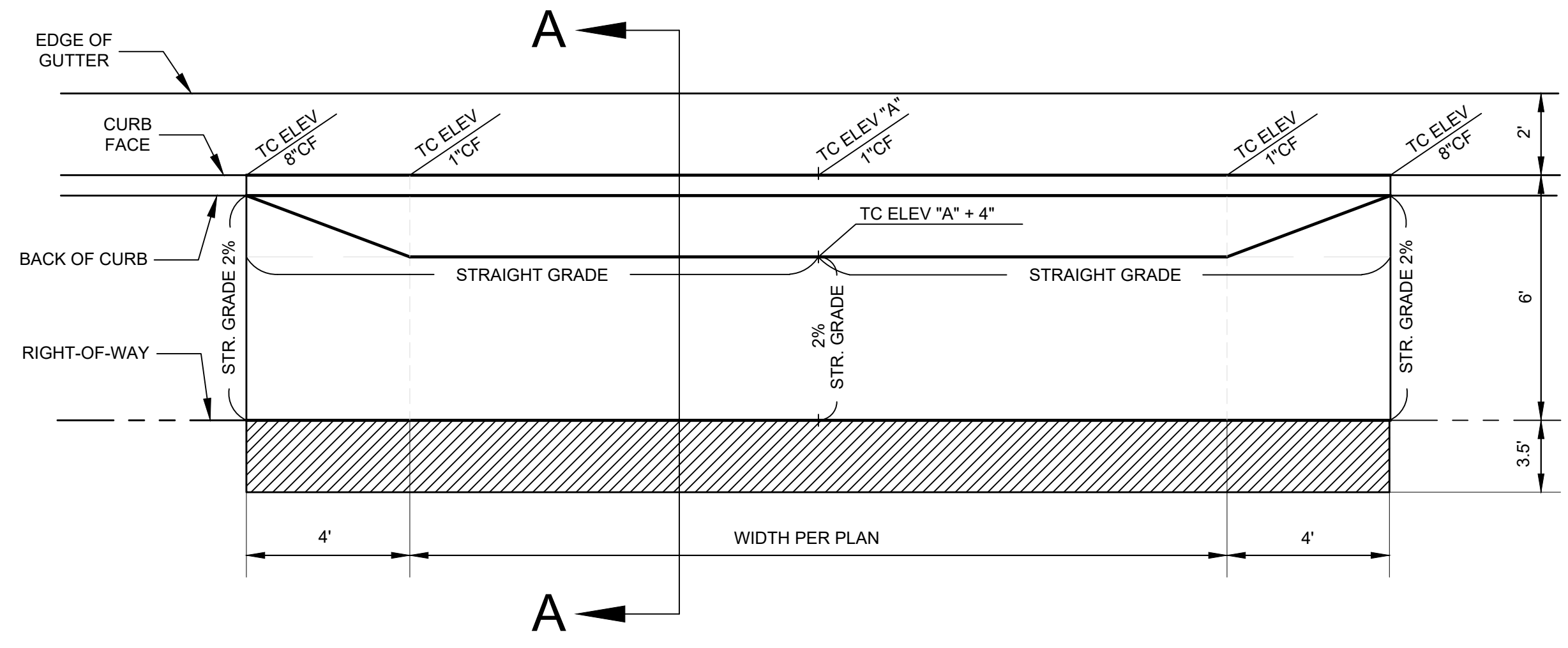

**DETAIL 'A' MODIFIED DRIVEWAY**  
N.T.S.

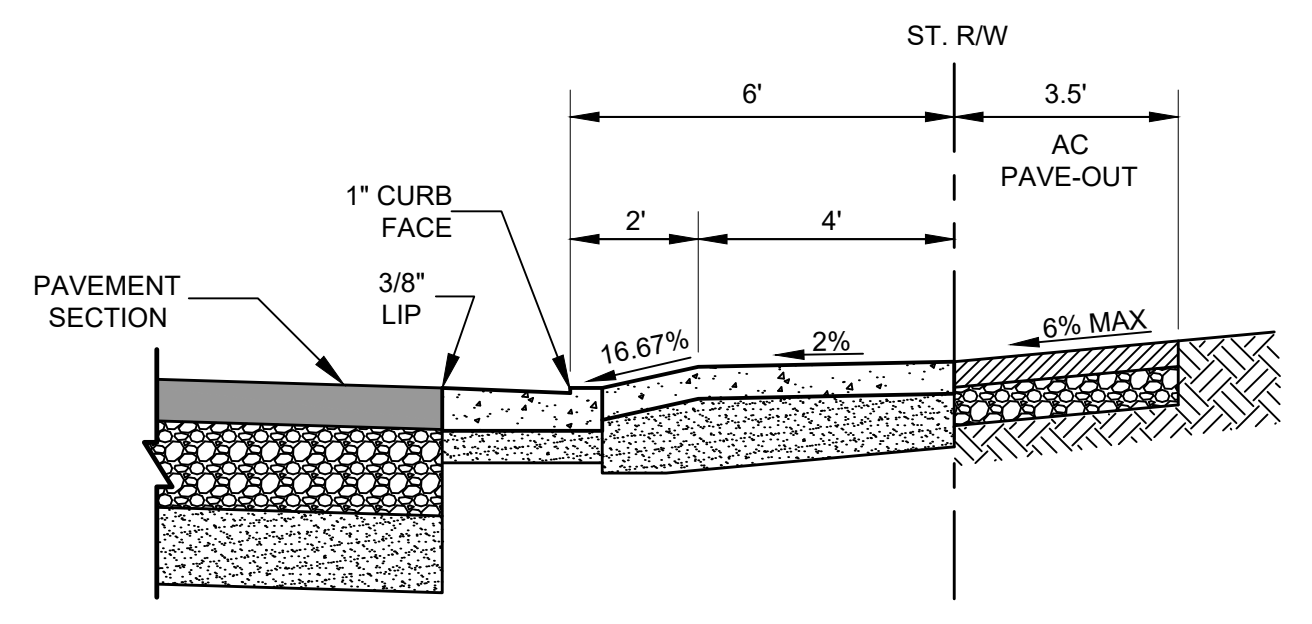

**SECTION 'A-A' - MODIFIED DRIVEWAY SECTION**  
N.T.S.

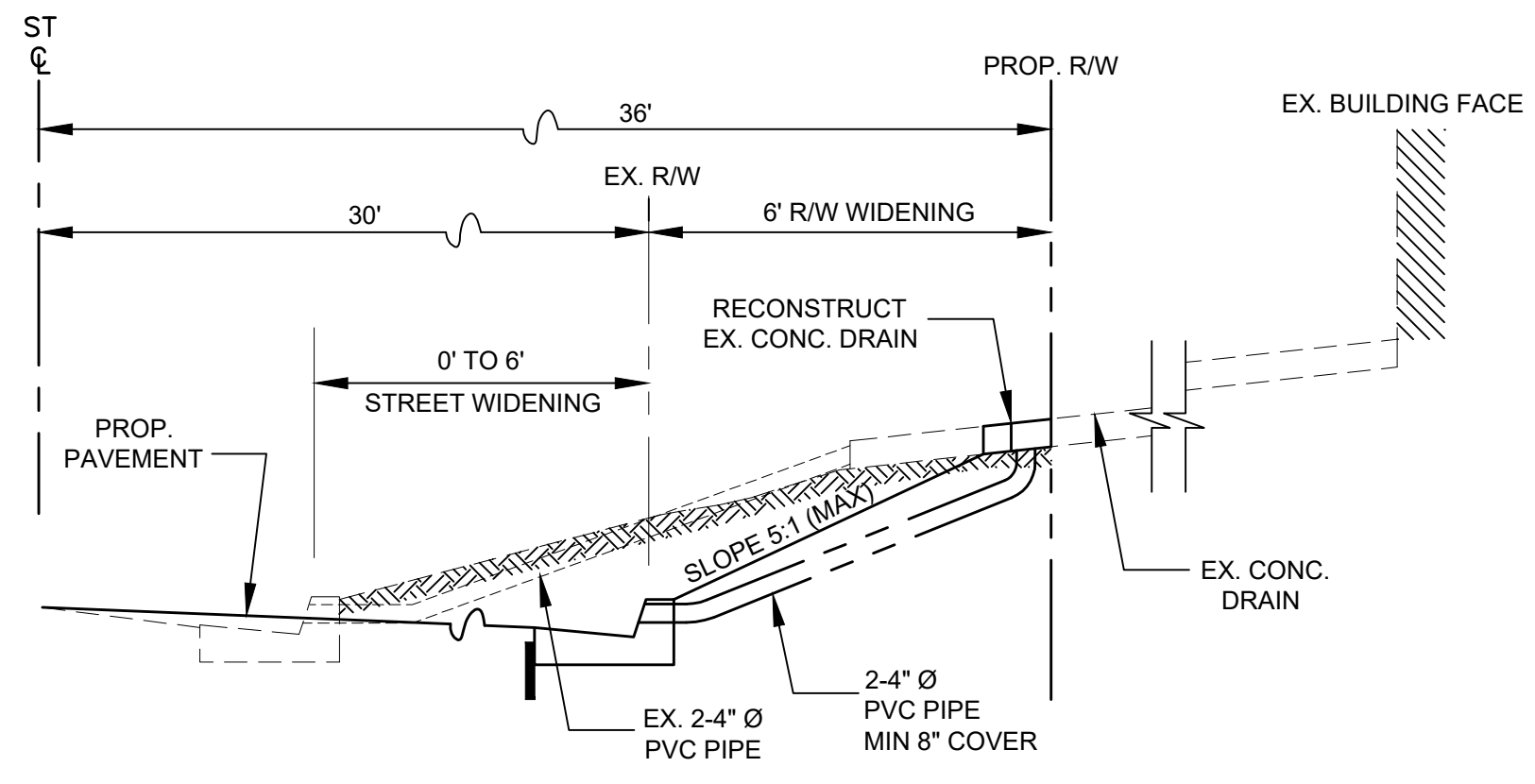

**DETAIL 'B' - TYPICAL 4' DIA. CURB DRAIN**  
N.T.S.

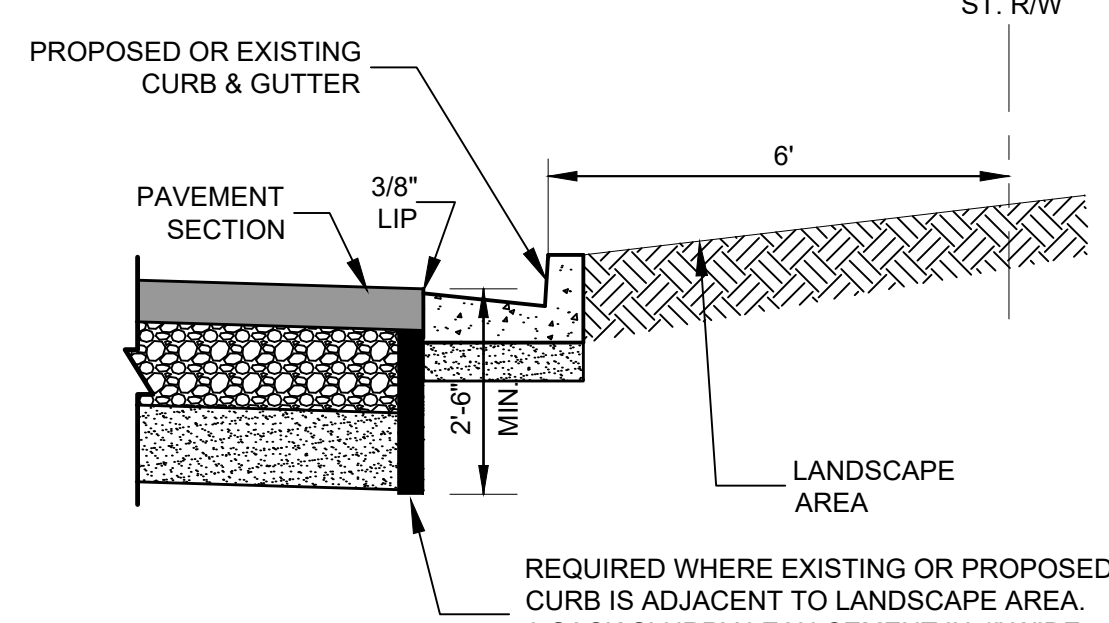

**DETAIL 'C' - MOISTURE CUT-OFF BARRIER**  
N.T.S.

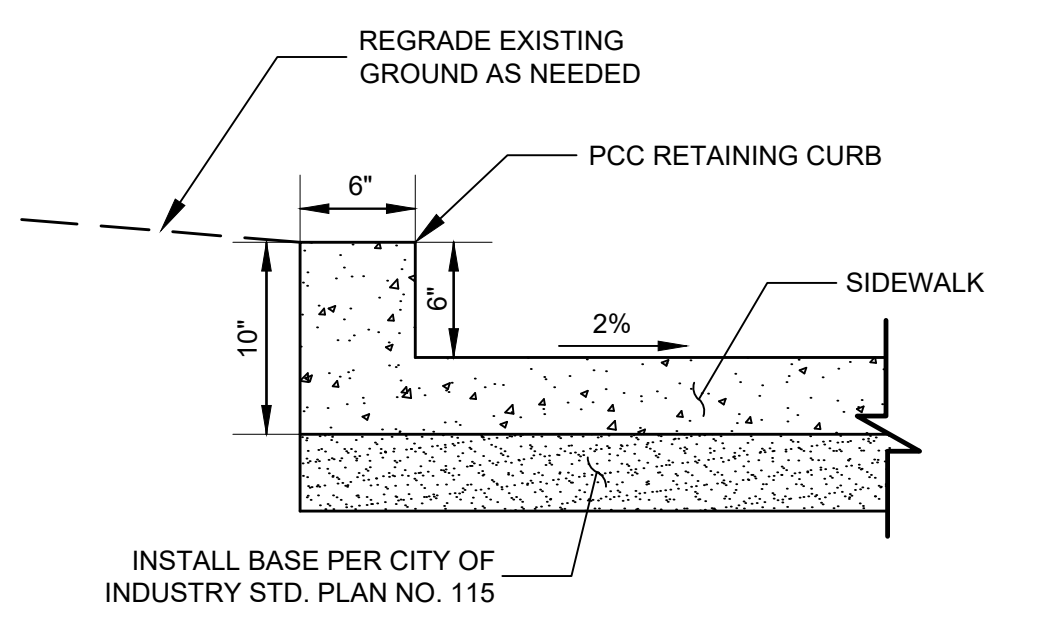

**DETAIL 'D' - PCC RETAINING CURB**  
N.T.S.

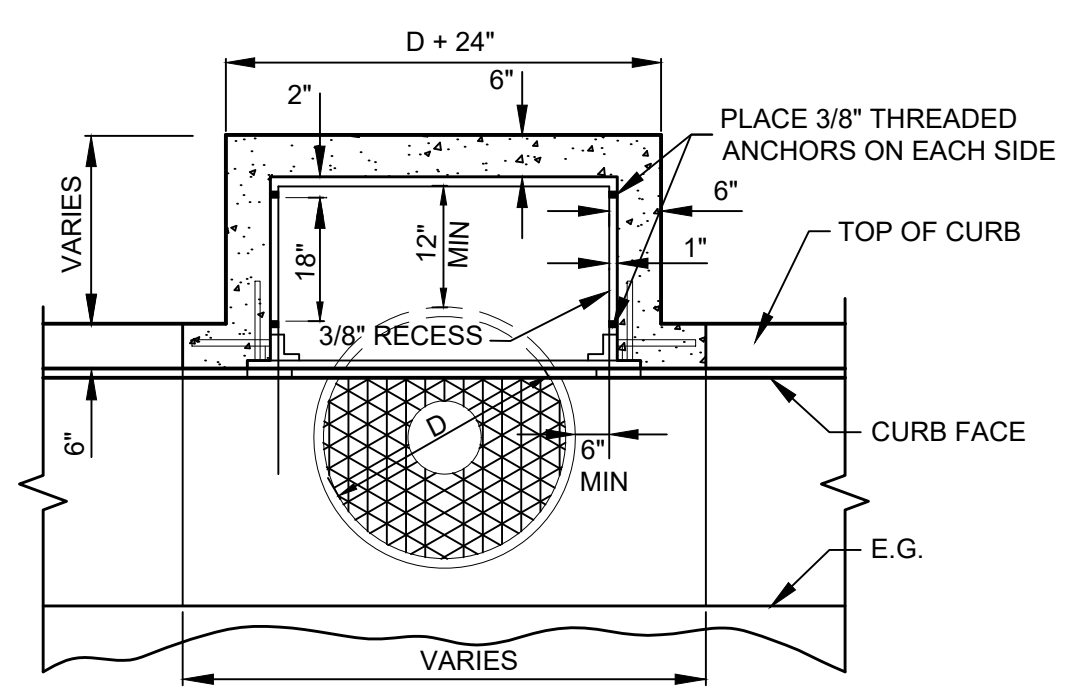
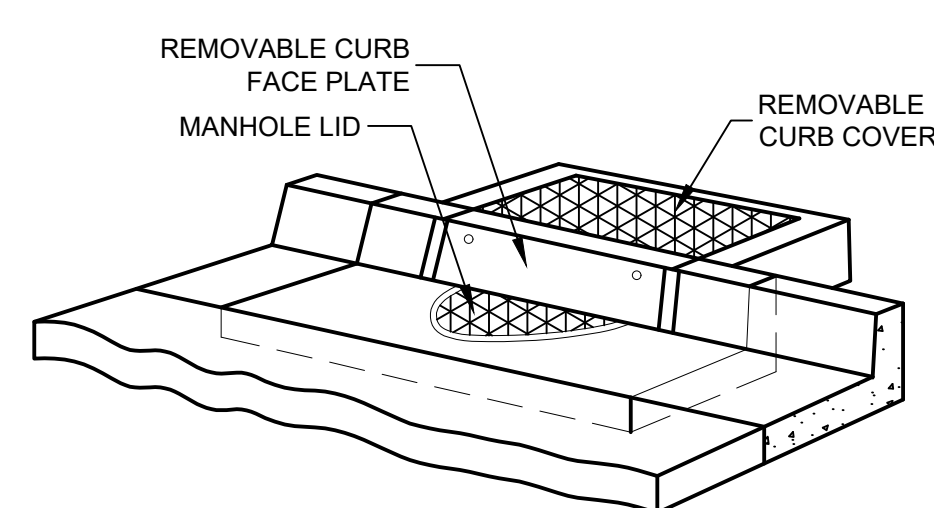

**DETAIL 'E' - REMOVABLE CURB FACE**  
N.T.S.

**CONSTRUCTION NOTES**

- ② - REMOVE ITEM PER PLAN.
- ③ - REMOVE AND HAUL EXISTING AC PAVEMENT INCLUDING BASE 20" DEEP.
- ④ - CONSTRUCT 13-1/2" CAB OVER 12" ENGINEERED FILL, INSTALL TWO LAYERS OF GEOGRID (TENSAR TX7-ONE), ONE LAYER AT BOTTOM OF CAI AND ONE LAYER AT 8" ABOVE SUBGRADE.
- ⑤ - CONSTRUCT 4" THICK ASPHALT BASE COURSE (PG-64-10-B).
- ⑥ - CONSTRUCT 2-1/2" THICK ASPHALT PAVEMENT SURFACE COURSE (PG 64).
- ⑧ - CONSTRUCT CURB AND GUTTER PER CITY OF INDUSTRY STD. PLAN NO. 112, TYPE PER PLAN, INCLUDING CRUSHED AGG. BASE.
- ⑩ - CONSTRUCT PCC SIDEWALK PER CITY OF INDUSTRY STD. PLAN NO. 115, INCLUDING CRUSHED AGG. BASE.
- ⑱ - CONSTRUCT PCC RETAINING CURB PER DETAIL "D" ON SHEET NO. 3

P:\2016\2016.0100.0001.47 Industry - San Jose Avenue Reconstruction Proj. No. CITY-1439\Cadd\Sheets\1610001.47 - 03 TYPICAL SECTIONS & DETAILS.dwg  
5/12/2022 10:57 AM

**BENCHMARK**  
B.M. CH-1 ELEV. 428.357 FT.  
1-3/8" BRASS CAP MONUMENT ON TOP OF WEST CURB CHARLIE ROAD 60'± NORTH OF RAILROAD ST. (2'± NORTH OF BCR)  
INDUSTRY, CA

NO.	DATE	REVISIONS	OK BY



**CITY OF INDUSTRY**  
INCORPORATED JUNE 18, 1957  
P.O. Box 3366, City of Industry, California 91744  
Administrative Offices: 15625 Mayor Dave Way (626) 333-2211

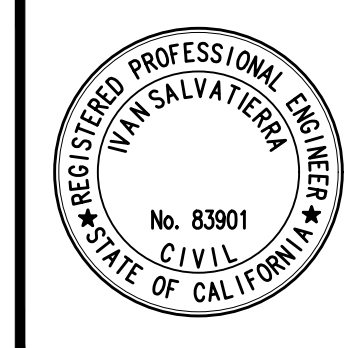

Plans Prepared by:  
**JMD**  
PLANNING | ENGINEERING | MANAGEMENT  
18645 East Gate Avenue, Suite 212  
City of Industry, CA 91748  
(626) 800-1137 Tel  
(626) 820-1138 Fax  
www.jmdaz.com  
UNDER THE SUPERVISION OF:  
IVAN SALVATIERRA RCE 83901 DATE: 5/12/2022

**CITY OF INDUSTRY**  
CLEMENT N. CALVILLO, PE, RCE 27743 DEPUTY CITY ENGINEER DATE: \_\_\_\_\_

**SAN JOSE AVENUE RECONSTRUCTION**  
STREET IMPROVEMENTS  
SAN JOSE AVENUE  
TYPICAL SECTIONS AND DETAILS  
1 OF 2

DESIGNED BY: D.D	CHECKED BY: D.S	JOB NO. MP08-09	SHEET 3 OF 9
DRAFTED BY: D.H	DATE: 09/15/2021	CONTRACT NO. CITY-1439	CONTRACT DRAWING OF

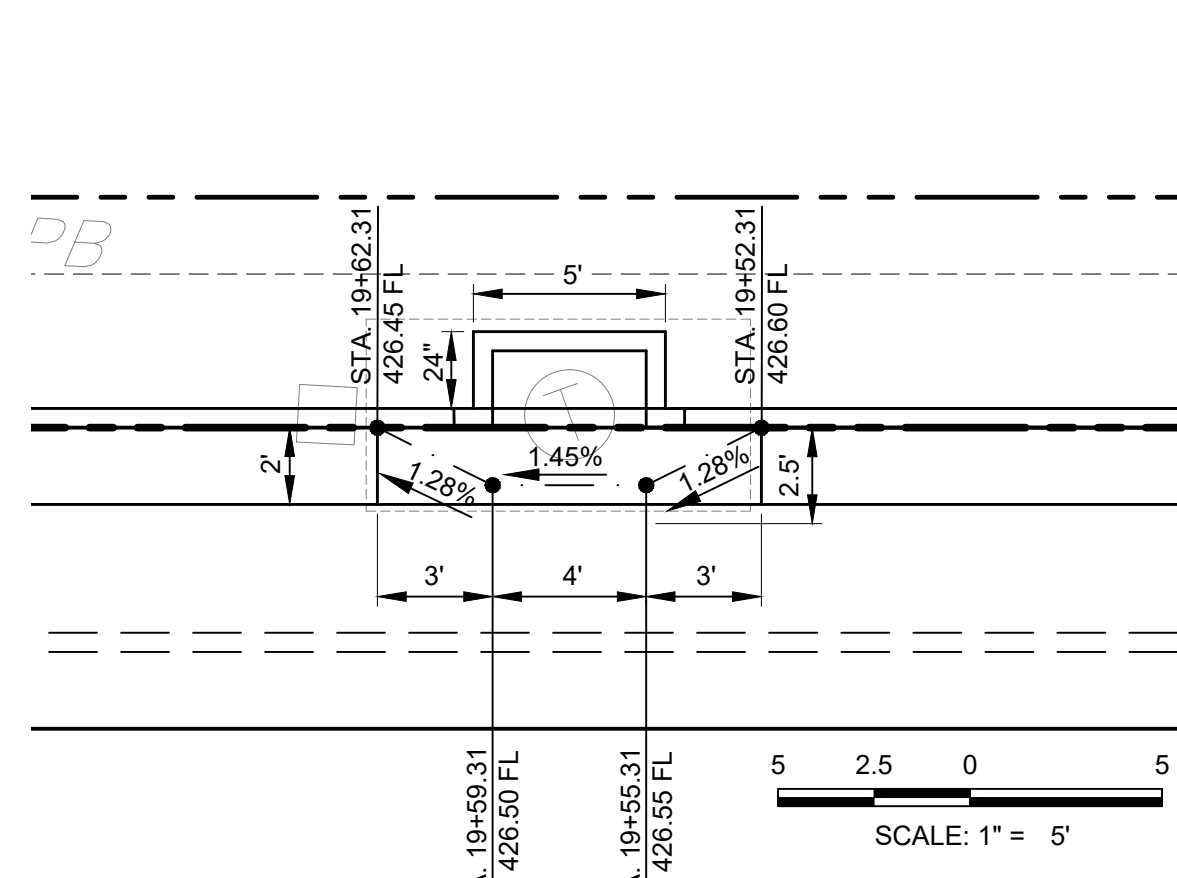

GTE MANHOLE ADJUSTMENT

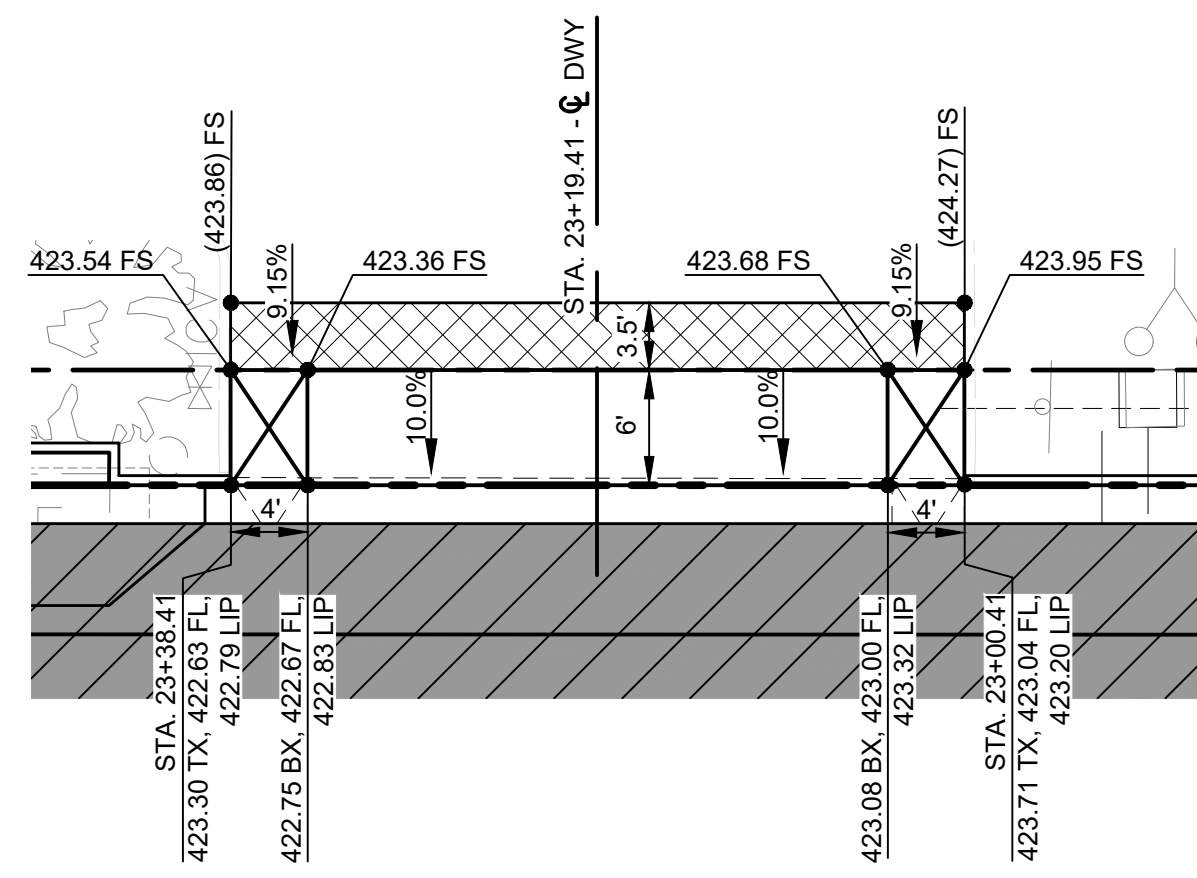

DRIVEWAY DETAIL (TYPE A, W-30', X-4', t-8')  
RIGHT OF CL

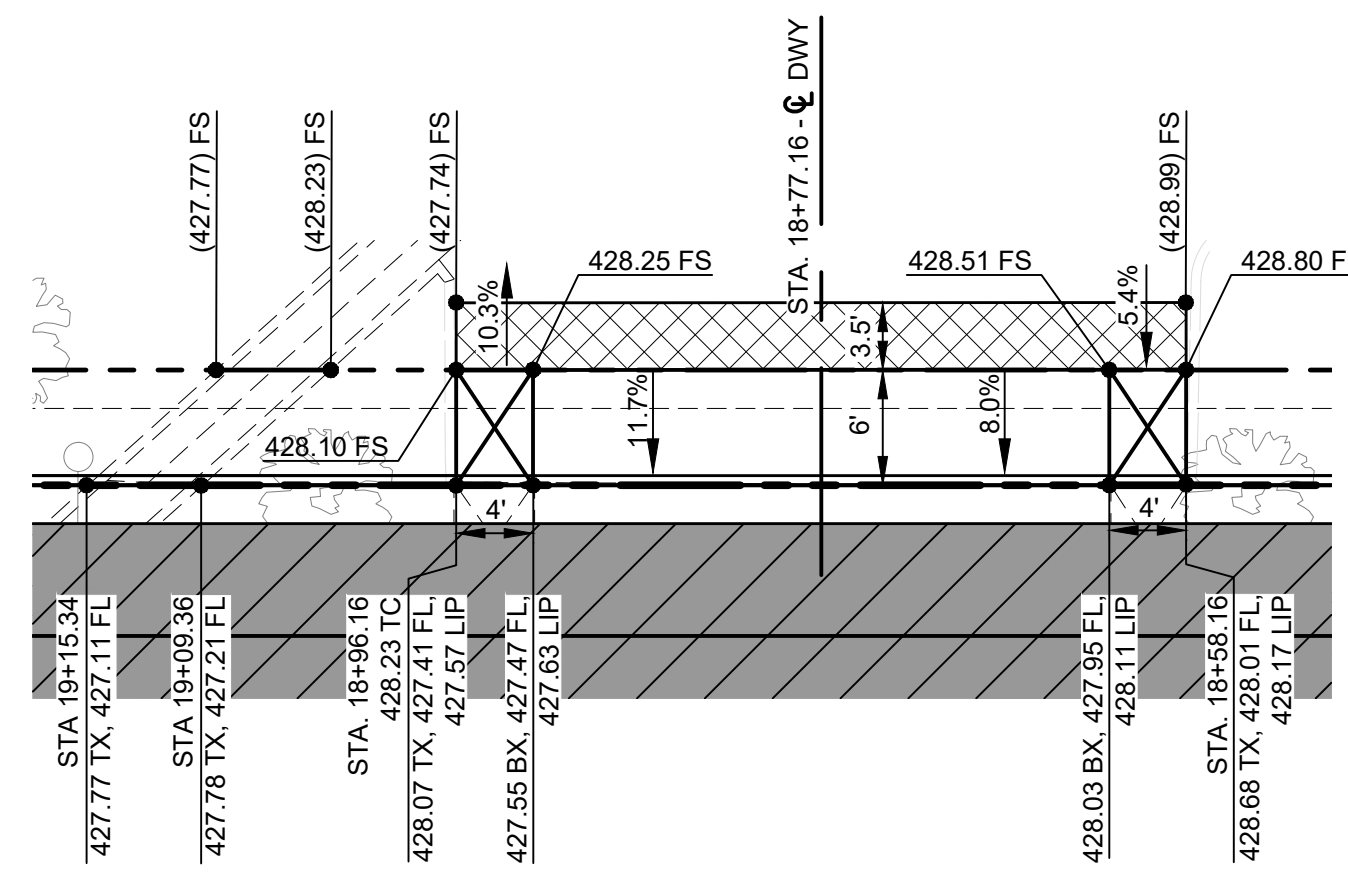

DRIVEWAY DETAIL (TYPE A, W-30', X-4', t-8')  
RIGHT OF CL

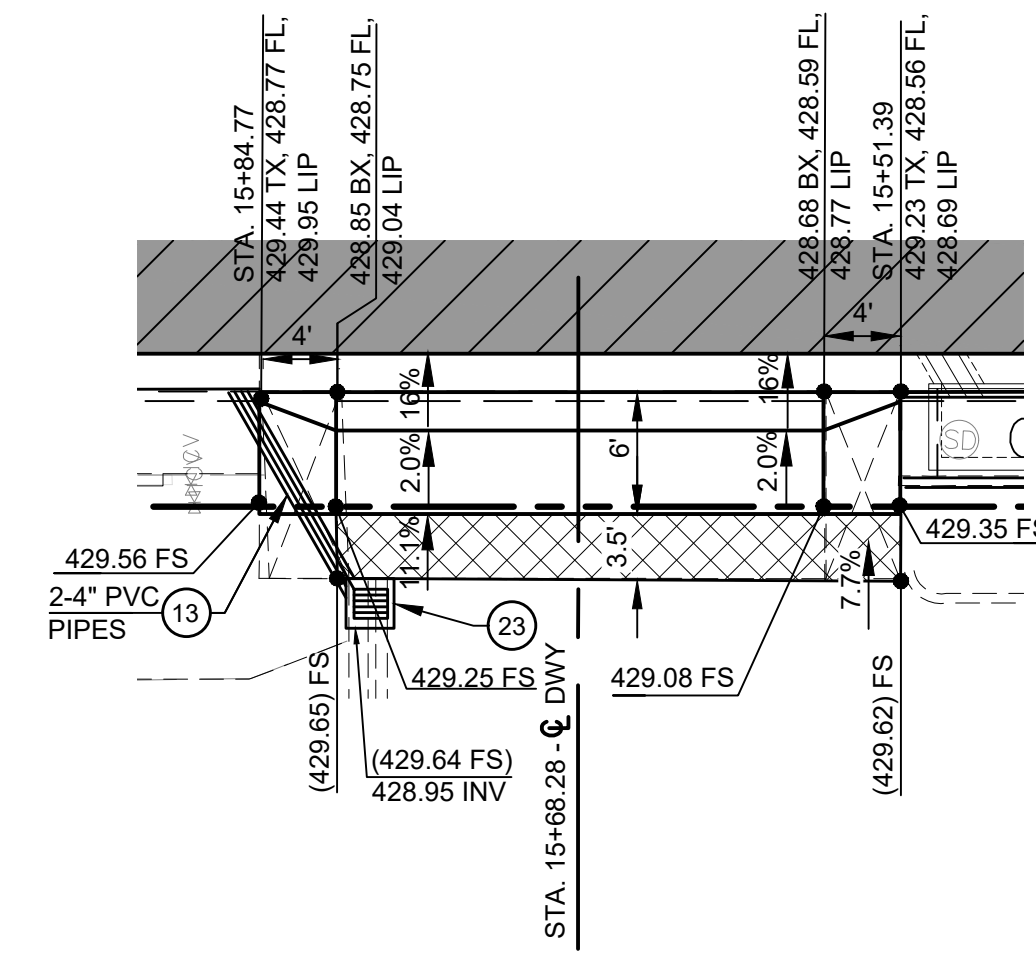

DRIVEWAY DETAIL (TYPE A, W-25', X-4', t-8')  
LEFT OF CL

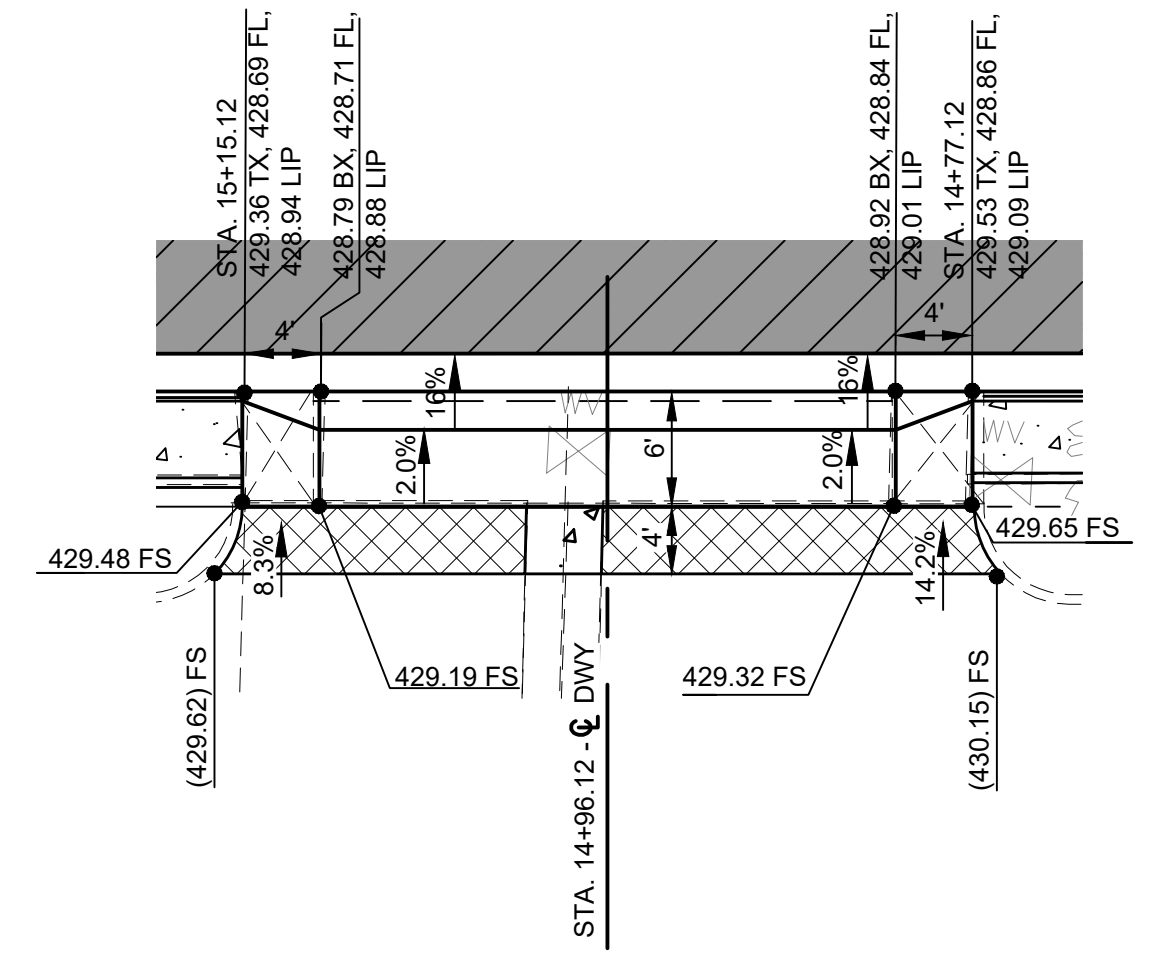

DRIVEWAY DETAIL (TYPE A, W-30', X-4', t-8')  
LEFT OF CL

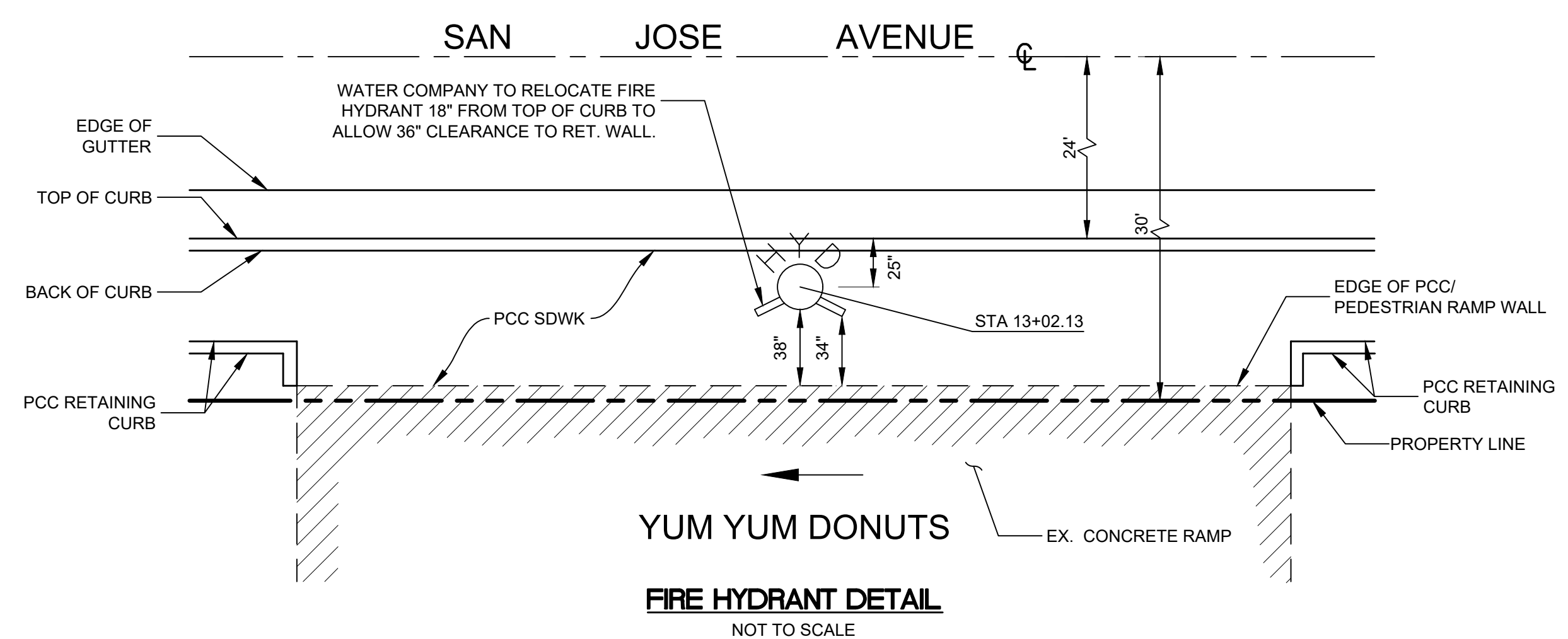

FIRE HYDRANT DETAIL  
NOT TO SCALE

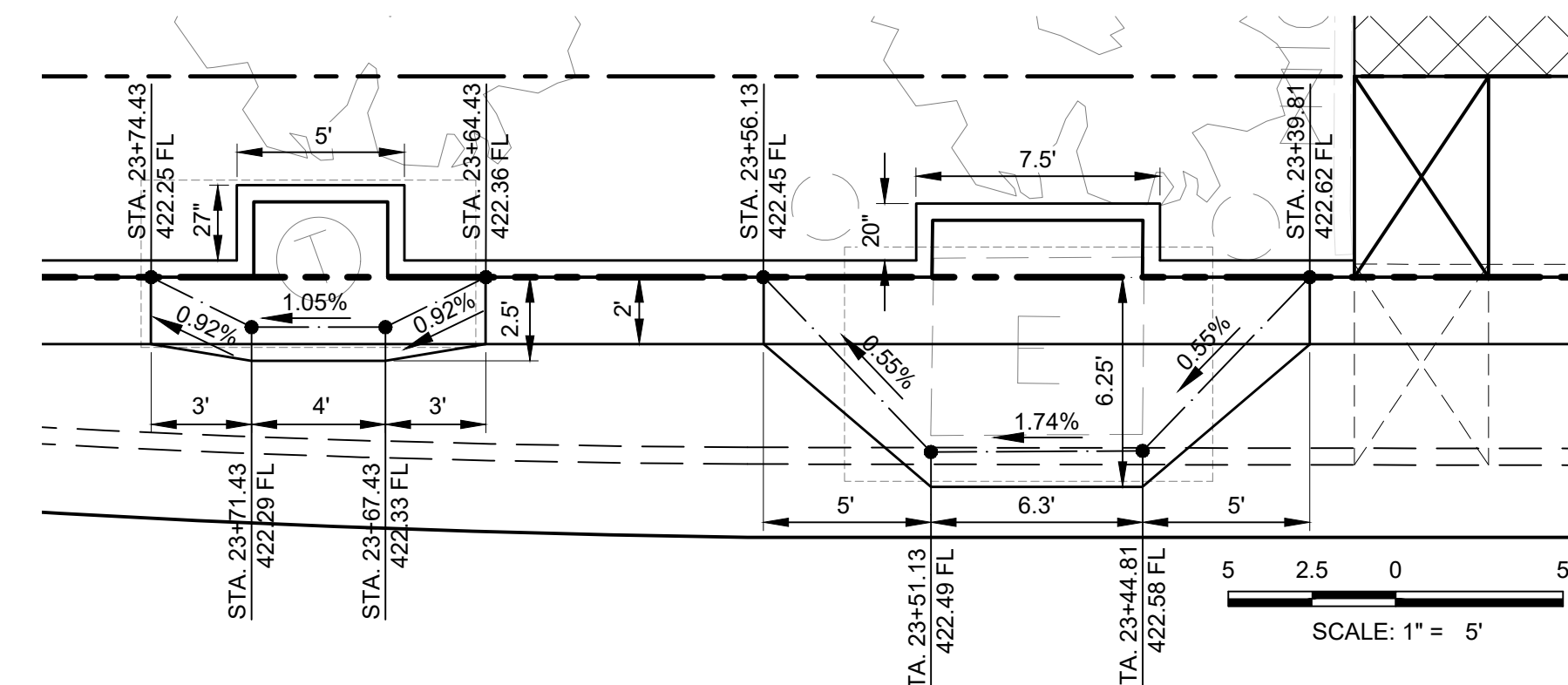

SCE ELECTRICAL MANHOLE ADJUSTMENT

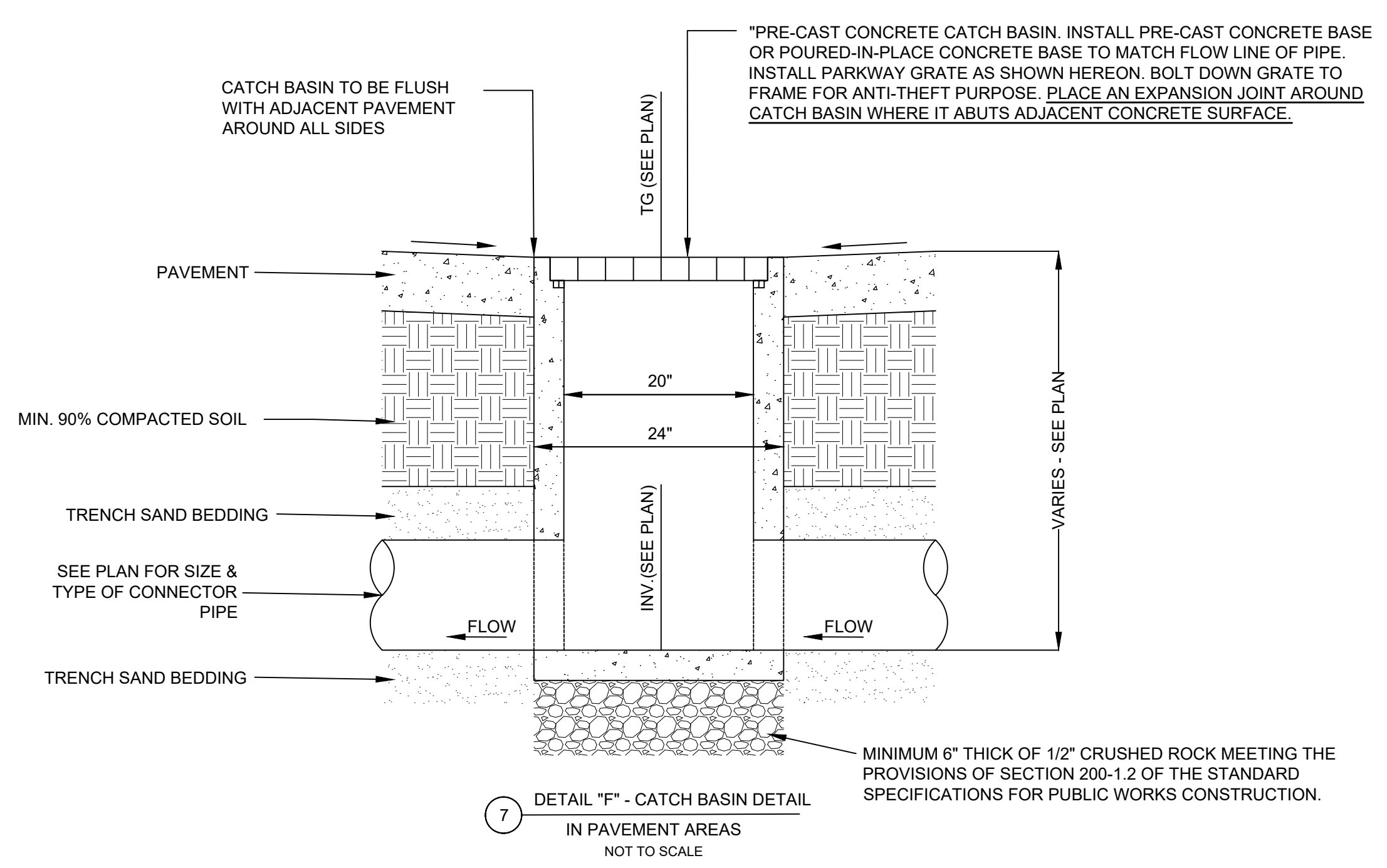

DETAIL 'F' - CATCH BASIN DETAIL  
IN PAVEMENT AREAS  
NOT TO SCALE

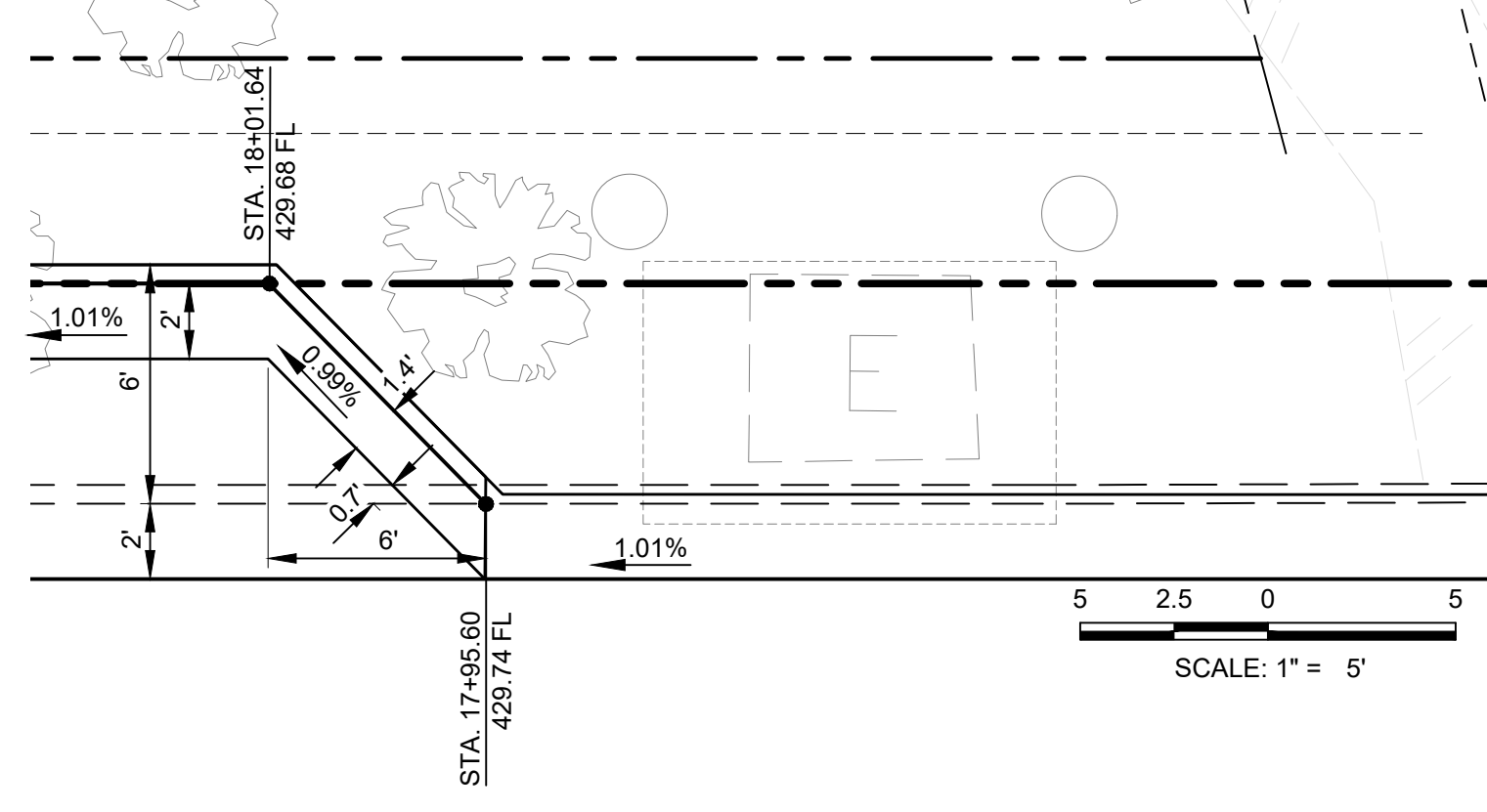

MATCH/JOIN PROP CURB AND GUTTER TO EXIST

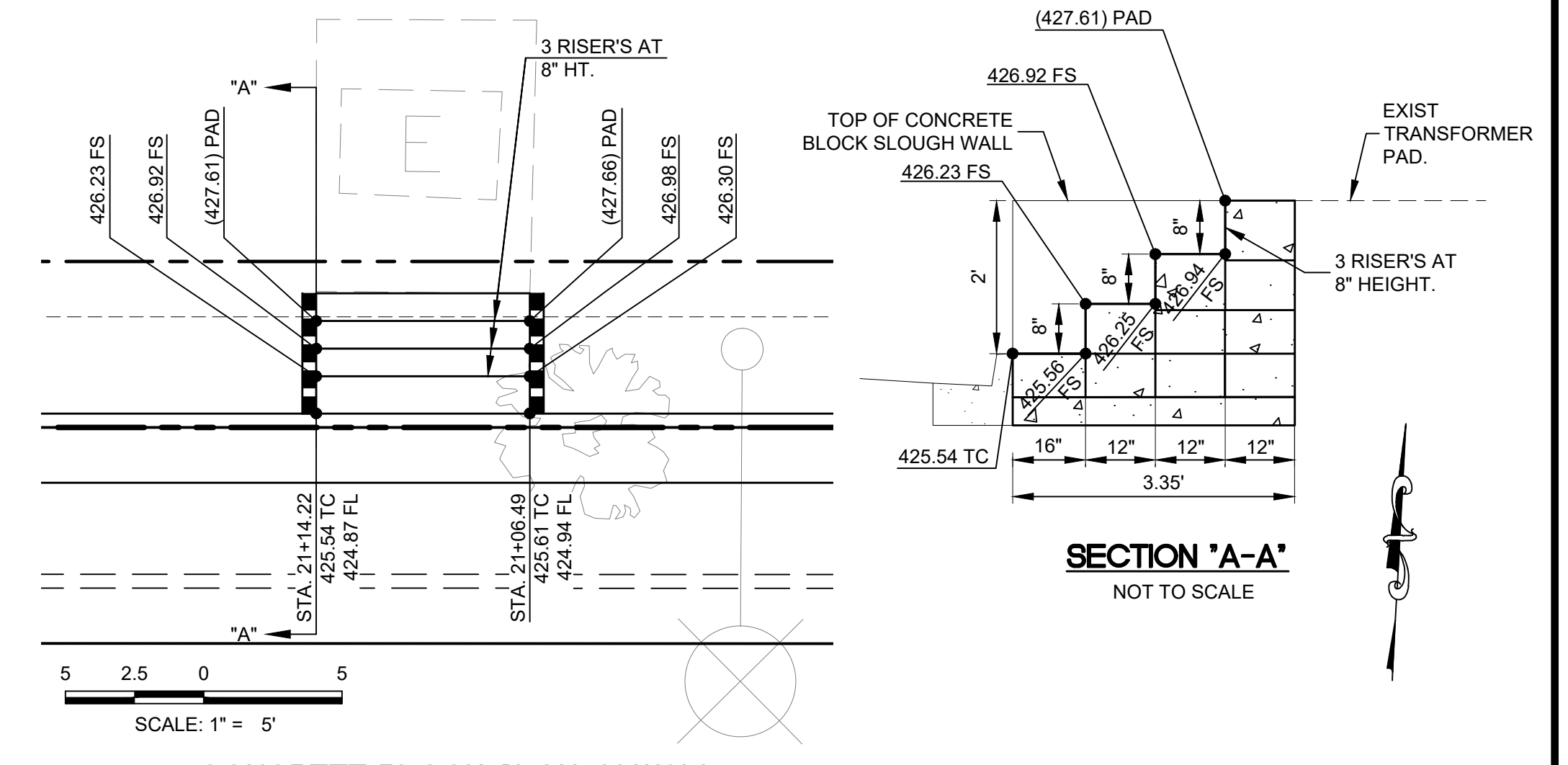

CONCRETE BLOCK SLOUGH WALL

- CONSTRUCTION NOTES**
- 13 - CONSTRUCT PARKWAY DRAIN NO. 2 PER CITY OF INDUSTRY STD. PLAN NO. 214, NO. OF PIPES PER PLAN.
  - 23 - CONSTRUCT CATCH BASIN WITH GRADING PER DETAIL F.

NO.	DATE	REVISIONS	OK BY



**CITY OF INDUSTRY**  
INCORPORATED JUNE 18, 1957  
P.O. Box 3366, City of Industry, California 91744  
Administrative Offices: 15625 Mayor Dave Way (626) 333-2211



Plans Prepared by:  
**JMD**  
PLANNING | ENGINEERING | MANAGEMENT  
18645 East Gate Avenue, Suite 212  
City of Industry, CA 91748  
(626) 800-1137 Tel  
(626) 800-1138 Fax  
www.jmdaz.com  
UNDER THE SUPERVISION OF:  
IVAN SALVATIERRA RCE 83901 DATE: 5/12/2022

**CITY OF INDUSTRY**  
CLEMENT N. CALVILLO, PE, RCE 27743 DEPUTY CITY ENGINEER DATE: \_\_\_\_\_

**SAN JOSE AVENUE RECONSTRUCTION**  
STREET IMPROVEMENTS  
SAN JOSE AVENUE  
TYPICAL SECTIONS AND DETAILS  
2 OF 2

DESIGNED BY: D.D CHECKED BY: D.S JOB NO. MP08-09  
DRAFTED BY: D.H DATE: 09/15/2021 CONTRACT NO. CITY-1439 SHEET 4 OF 9

CONTRACT DRAWING OF

P:\2016\2016.0100.0001.47 Industry - San Jose Avenue Reconstruction Proj. No. CITY-1439\Cadd\Sheets\1610001.47 - 04 TYPICAL SECTION & DETAILS.dwg 5/12/2022 11:00 AM

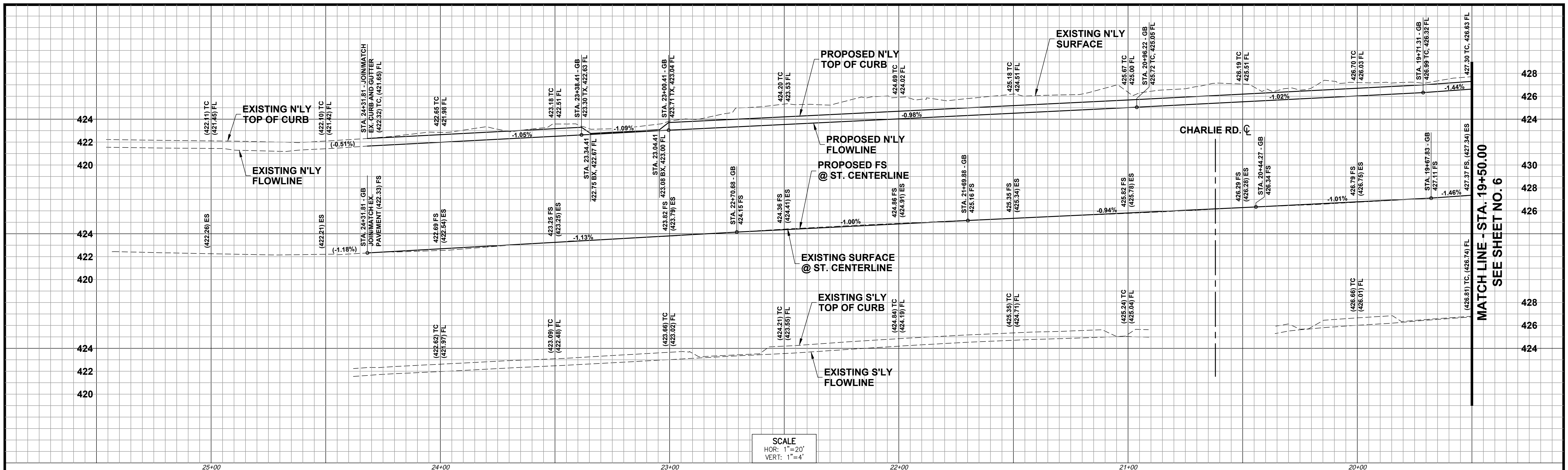

SCALE  
HOR: 1"=20'  
VERT: 1"=4'

MATCH LINE - STA. 19+50.00  
SEE SHEET NO. 6

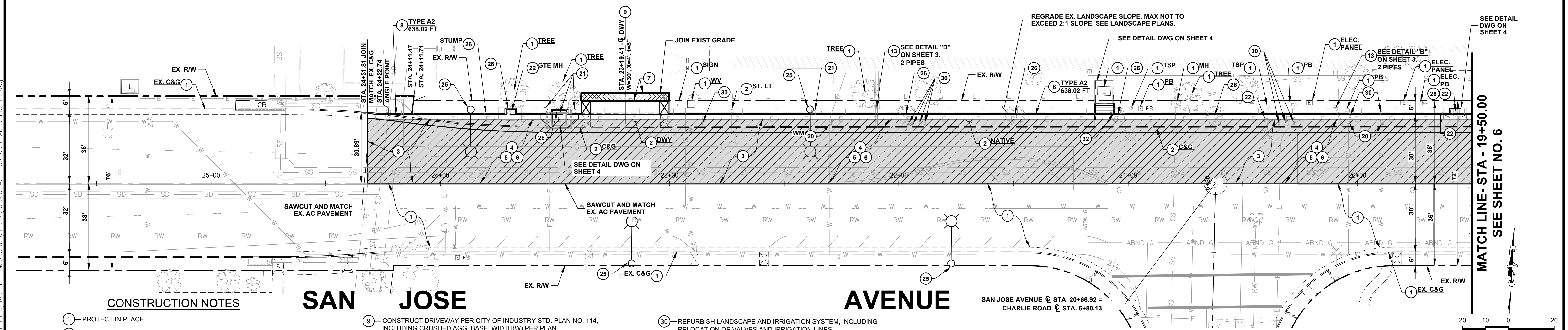

MATCH LINE - STA. 19+50.00  
SEE SHEET NO. 6

**CONSTRUCTION NOTES**

- 1 - PROTECT IN PLACE.
- 2 - REMOVE ITEM PER PLAN.
- 3 - REMOVE AND HAUL EXISTING AC PAVEMENT INCLUDING BASE 20" DEEP.
- 4 - CONSTRUCT 13-1/2" CAB OVER 12" ENGINEERED FILL, INSTALL TWO LAYERS OF GEOGRID (TENSAR TX7-ONE), ONE LAYER AT BOTTOM OF CAB AND ONE LAYER AT 8" ABOVE SUBGRADE.
- 5 - CONSTRUCT 4" THICK ASPHALT BASE COURSE (PG-64-10-B).
- 6 - CONSTRUCT 2-1/2" THICK ASPHALT PAVEMENT SURFACE COURSE (PG-64-10-C).
- 7 - CONSTRUCT 4" THICK ASPHALT AC PAVEMENT (PG-64-10-B) OVER 6" CAB AT THE BACK OF PROPOSED DRIVEWAY.
- 8 - CONSTRUCT CURB AND GUTTER PER CITY OF INDUSTRY STD. PLAN NO. 112, TYPE PER PLAN, INCLUDING CRUSHED AGG. BASE.
- 9 - CONSTRUCT DRIVEWAY PER CITY OF INDUSTRY STD. PLAN NO. 114, INCLUDING CRUSHED AGG. BASE. WIDTH(W) PER PLAN.
- 13 - CONSTRUCT PARKWAY DRAIN NO. 2 PER CITY OF INDUSTRY STD. PLAN NO. 214, NO. OF PIPES PER PLAN.
- 20 - WATER STRUCTURE/FIRE HYDRANT/AIR VENTS/WATER METERS BOXES TO BE ADJUSTED/REMOVED/RELOCATED/INSTALLED BY ROWLAND WATER DISTRICT.
- 21 - EXISTING SCE ELECTRICAL MANHOLE/VAULT/PULL BOX/STRUCTURES TO BE ADJUSTED/RELOCATED TO GRADE BY SCE.
- 22 - RELOCATE AND ADJUST GTE MANHOLE TO GRADE.
- 25 - PROPOSED STREET LIGHT. SEE STREET LIGHT PLANS.
- 26 - REMOVE EXISTING TREE. SEE LANDSCAPE PLANS.
- 30 - REFURBISH LANDSCAPE AND IRRIGATION SYSTEM, INCLUDING RELOCATION OF VALVES AND IRRIGATION LINES.

**LEGEND**

- 2-1/2" ASPHALT PAVEMENT (PG 64-10-C)
- 4" BASE PAVEMENT (PG 64-10-B)
- 4" AC PAVEMENT (PG-64-10-B) OVER 6" CAB.

**BENCHMARK**  
B.M. CH-1 ELEV. 428.357 FT.  
1-3/8" BRASS CAP MONUMENT ON TOP OF WEST CURB CHARLIE ROAD 60'± NORTH OF RAILROAD ST. (2'± NORTH OF BCR)  
INDUSTRY, CA

NO.	DATE	REVISIONS	OK BY



**CITY OF INDUSTRY**  
INCORPORATED JUNE 18, 1957  
P.O. Box 3366, City of Industry, California 91744  
Administrative Offices: 15625 Mayor Dave Way (626) 333-2211



Plans Prepared by:  
**JMD**  
PLANNING | ENGINEERING | MANAGEMENT  
18645 East Gate Avenue, Suite 212  
City of Industry, CA 91748  
(626) 820-1137 Tel  
(626) 820-1138 Fax  
www.jmdaz.com  
UNDER THE SUPERVISION OF  
IVAN SALVATIERRA RCE 83901  
5/12/2022  
DATE

**CITY OF INDUSTRY**  
CLEMENT N. CALVILLO, PE, RCE 27743 DEPUTY CITY ENGINEER DATE

**SAN JOSE AVENUE RECONSTRUCTION**  
STREET IMPROVEMENTS  
SAN JOSE AVENUE  
PLAN AND PROFILE  
FROM STA. 19+50.00 TO STA. 24+31.81

DESIGNED BY: D.D CHECKED BY: D.S JOB NO. MP08-09  
DRAFTED BY: D.H DATE: 09/15/2021 CONTRACT NO. CITY-1439 SHEET 5 OF 9

CONTRACT DRAWING OF

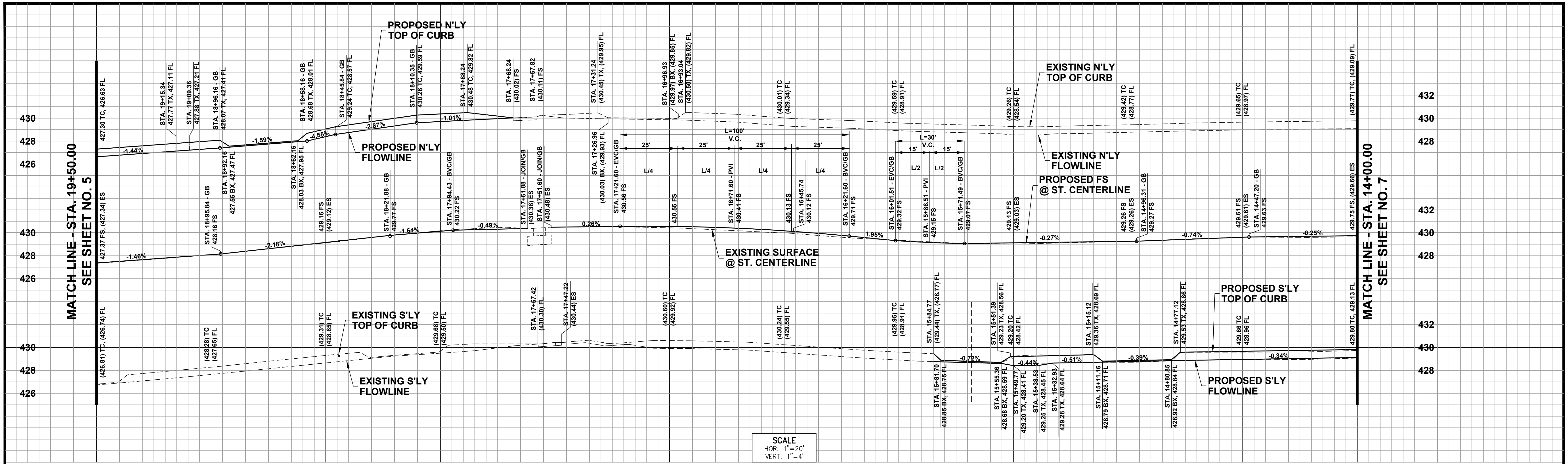

SCALE  
HOR: 1" = 20'  
VERT: 1" = 4'

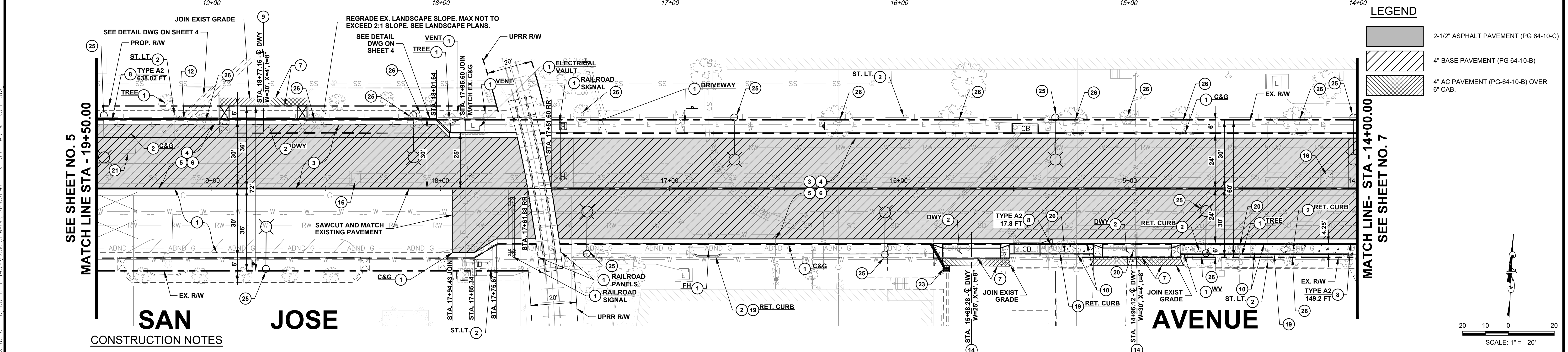

**LEGEND**

	2-1/2" ASPHALT PAVEMENT (PG 64-10-C)
	4" BASE PAVEMENT (PG 64-10-B)
	4" AC PAVEMENT (PG 64-10-B) OVER 6" CAB.

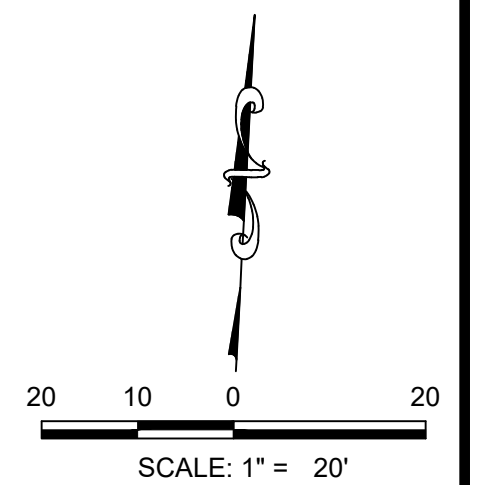

- CONSTRUCTION NOTES**
- PROTECT IN PLACE.
  - REMOVE ITEM PER PLAN.
  - REMOVE AND HAUL EXISTING AC PAVEMENT INCLUDING BASE 20" DEEP.
  - CONSTRUCT 13-1/2" CAB OVER 12" ENGINEERED FILL, INSTALL TWO LAYERS OF GEOGRID (TENSAR TX7-ONE), ONE LAYER AT BOTTOM OF CAB AND ONE LAYER AT 8" ABOVE SUBGRADE.
  - CONSTRUCT 4" THICK ASPHALT BASE COURSE (PG-64-10-B).
  - CONSTRUCT 2-1/2" THICK ASPHALT PAVEMENT SURFACE COURSE (PG 64-10-C).

- CONSTRUCT 4" THICK ASPHALT AC PAVEMENT (PG-64-10-B) OVER 6" CAB AT THE BACK OF PROPOSED DRIVEWAY.
- CONSTRUCT CURB AND GUTTER PER CITY OF INDUSTRY STD. PLAN NO. 112, TYPE PER PLAN, INCLUDING CRUSHED AGG. BASE.
- CONSTRUCT DRIVEWAY PER CITY OF INDUSTRY STD. PLAN NO. 114, INCLUDING CRUSHED AGG. BASE, WIDTH(W) PER PLAN.
- CONSTRUCT PCC SIDEWALK PER CITY OF INDUSTRY STD. PLAN NO. 115, INCLUDING CRUSHED AGG. BASE.
- CONSTRUCT CATCH BASIN LOCAL DEPRESSION PER CITY OF INDUSTRY STD. PLAN NO. 212.

- REMOVE AND RECONSTRUCT PARKWAY DRAIN NO. 1 PER CITY OF INDUSTRY STD. PLAN NO. 213.
- CONSTRUCT MODIFIED DRIVEWAY APPROACH PER SPPWC STD. PLAN NO. 110-2, TYPE B, AND PER DETAIL "A" ON SHEET NO. 3, INCLUDING CRUSHED AGG. BASE, WIDTH(W), WING(X), AND THICKNESS(I) PER PLAN.
- ADJUST MANHOLE FRAME AND COVER TO GRADE PER SPPWC STD. PLAN NO. 205-2.
- CONSTRUCT PCC RETAINING CURB PER DETAIL "D" ON SHEET NO. 3.
- WATER STRUCTURE/FIRE HYDRANT/AIR VENTS/WATER METERS BOXES TO BE ADJUSTED/REMOVED/RELOCATED/INSTALLED BY ROWLAND WATER DISTRICT.

- EXISTING SCE ELECTRICAL MANHOLE/VAULT/PULL BOX/STRUCTURES TO BE ADJUSTED/RELOCATED TO GRADE BY SCE.
- CONSTRUCT CATCH BASIN WITH GRADING PER DETAIL F.
- PROPOSED STREET LIGHT. SEE STREET LIGHT PLANS.
- REMOVE EXISTING TREE. SEE LANDSCAPE PLANS.

**BENCHMARK**  
B.M. CH-1 ELEV. 428.357 FT.  
1-3/8" BRASS CAP MONUMENT ON TOP OF WEST CURB CHARLIE ROAD 60'± NORTH OF RAILROAD ST. (2'± NORTH OF BCR)  
INDUSTRY, CA

NO.	DATE	REVISIONS	OK BY

**CITY OF INDUSTRY**  
INCORPORATED JUNE 18, 1957  
P.O. Box 3366, City of Industry, California 91744  
Administrative Offices: 15625 Mayor Dave Way (626) 333-2211



Plans Prepared by:  
**JMD**  
PLANNING ENGINEERING MANAGEMENT  
18645 East Gate Avenue, Suite 212  
City of Industry, CA 91744  
(626) 800-1137 Tel  
(626) 800-1138 Fax  
www.jmdaz.com  
UNDER THE SUPERVISION OF:  
IVAN SALVATIERRA RCE 83901  
5/12/2022 DATE

**CITY OF INDUSTRY**  
CLEMENT N. CALVILLO, PE, RCE 27743 DEPUTY CITY ENGINEER DATE  
**SAN JOSE AVENUE RECONSTRUCTION**  
STREET IMPROVEMENTS  
**SAN JOSE AVENUE**  
PLAN AND PROFILE  
FROM STA. 14+00.00 TO STA. 19+50.00  
DESIGNED BY: D.D CHECKED BY: D.S JOB NO. MP08-09  
DRAFTED BY: D.H DATE: 09/15/2021 CONTRACT NO. CITY-1439 SHEET 6 OF 9  
CONTRACT DRAWING OF

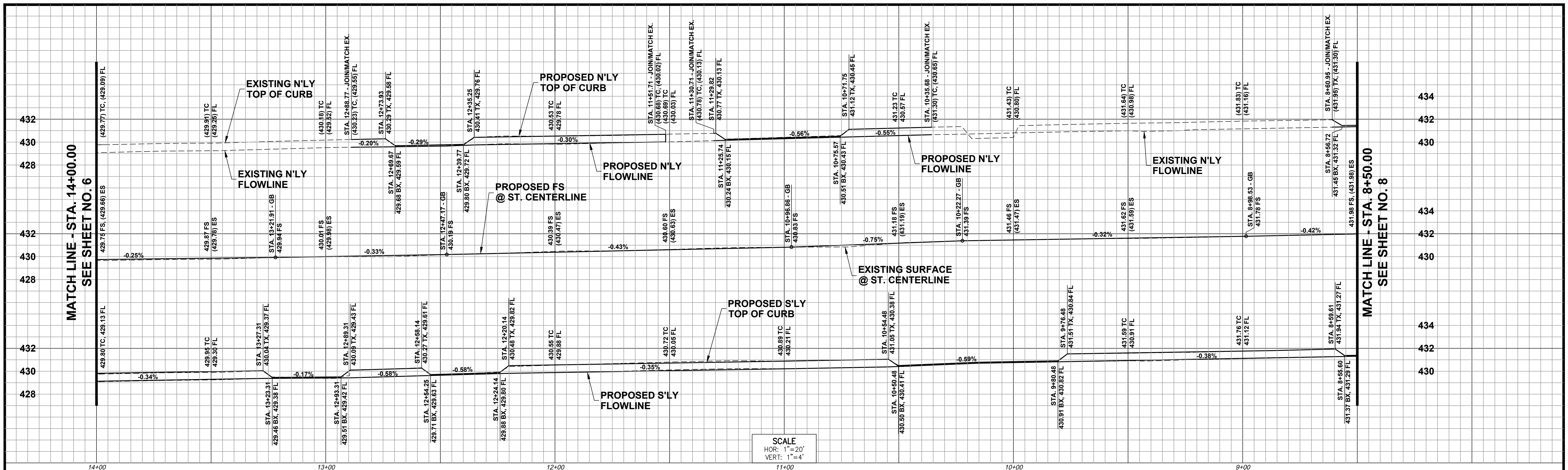

SCALE  
HOR: 1" = 20'  
VERT: 1" = 4'

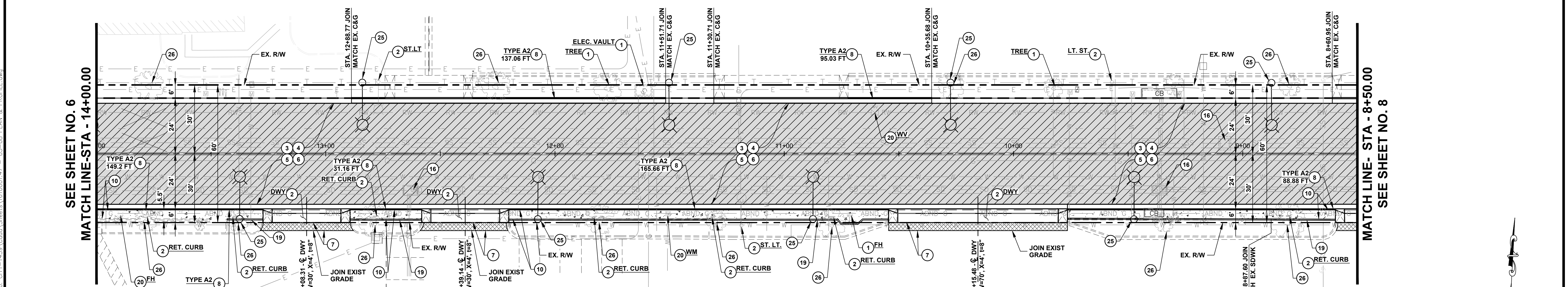

SCALE: 1" = 20'

**CONSTRUCTION NOTES**

- 1 - PROTECT IN PLACE.
- 2 - REMOVE ITEM PER PLAN.
- 3 - REMOVE AND HAUL EXISTING AC PAVEMENT INCLUDING BASE 20" DEEP.
- 4 - CONSTRUCT 13-1/2" CAB OVER 12" ENGINEERED FILL, INSTALL TWO LAYERS OF GEOGRID (TENSAR TX7-ONE), ONE LAYER AT BOTTOM OF CAB AND ONE LAYER AT 8" ABOVE SUBGRADE.
- 5 - CONSTRUCT 4" THICK ASPHALT BASE COURSE (PG-64-10-B).
- 6 - CONSTRUCT 2-1/2" THICK ASPHALT PAVEMENT SURFACE COURSE (PG 64-10-C).
- 7 - CONSTRUCT 4" THICK ASPHALT AC PAVEMENT (PG-64-10-B) OVER 6" CAB AT THE BACK OF PROPOSED DRIVEWAY.
- 8 - CONSTRUCT CURB AND GUTTER PER CITY OF INDUSTRY STD. PLAN NO. 112, TYPE PER PLAN, INCLUDING CRUSHED AGG. BASE.
- 10 - CONSTRUCT PCC SIDEWALK PER CITY OF INDUSTRY STD. PLAN NO. 115, INCLUDING CRUSHED AGG. BASE.
- 14 - CONSTRUCT MODIFIED DRIVEWAY APPROACH PER SPPWC STD. PLAN NO. 110-2, TYPE B, AND PER DETAIL "A" ON SHEET NO. 3, INCLUDING CRUSHED AGG. BASE, WIDTH(W), WING(X), AND THICKNESS(I) PER PLAN.
- 16 - ADJUST MANHOLE FRAME AND COVER TO GRADE PER SPPWC STD. PLAN NO. 205-2.
- 19 - CONSTRUCT PCC RETAINING CURB PER DETAIL "D" ON SHEET NO. 3.
- 20 - WATER STRUCTURE/FIRE HYDRANT/AIR VENTS/WATER METERS BOXES TO BE ADJUSTED/REMOVED/RELOCATED/INSTALLED BY ROWLAND WATER DISTRICT.
- 25 - PROPOSED STREET LIGHT. SEE STREET LIGHT PLANS.
- 26 - REMOVE EXISTING TREE. SEE LANDSCAPE PLANS.

**LEGEND**

	2-1/2" ASPHALT PAVEMENT (PG 64-10-C)
	4" BASE PAVEMENT (PG 64-10-B)
	4" AC PAVEMENT (PG-64-10-B) OVER 6" CAB.

**BENCHMARK**  
B.M. CH-1 ELEV. 428.357 FT.  
1-3/8" BRASS CAP MONUMENT ON TOP OF WEST CURB CHARLIE ROAD 60'± NORTH OF RAILROAD ST. (2'± NORTH OF BCR)  
INDUSTRY, CA

NO.	DATE	REVISIONS	OK BY



**CITY OF INDUSTRY**  
INCORPORATED JUNE 18, 1957  
P.O. Box 3366, City of Industry, California 91744  
Administrative Offices: 15625 Mayor Dave Way (626) 333-2211

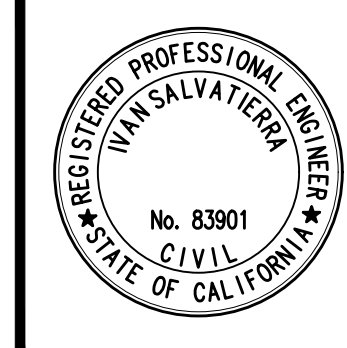

Plans Prepared by:  
**JMD**  
PLANNING | ENGINEERING | MANAGEMENT  
18645 East Gate Avenue, Suite 212  
City of Industry, CA 91748  
(626) 800-1137 Tel  
(626) 820-1138 Fax  
www.jmd.com  
UNDER THE SUPERVISION OF:  
IVAN SALVATIERRA RCE 83901  
5/12/2022 DATE

**CITY OF INDUSTRY**  
CLEMENT N. CALVILLO, PE, RCE 27743 DEPUTY CITY ENGINEER DATE  
**SAN JOSE AVENUE RECONSTRUCTION**  
STREET IMPROVEMENTS  
**SAN JOSE AVENUE**  
PLAN AND PROFILE  
FROM STA. 8+50.00 TO STA. 14+00.00  
DESIGNED BY: D.D CHECKED BY: D.S JOB NO. MP08-09 SHEET 7 OF 9  
DRAFTED BY: D.H DATE: 09/15/2021 CONTRACT NO. CITY-1439  
CONTRACT DRAWING OF

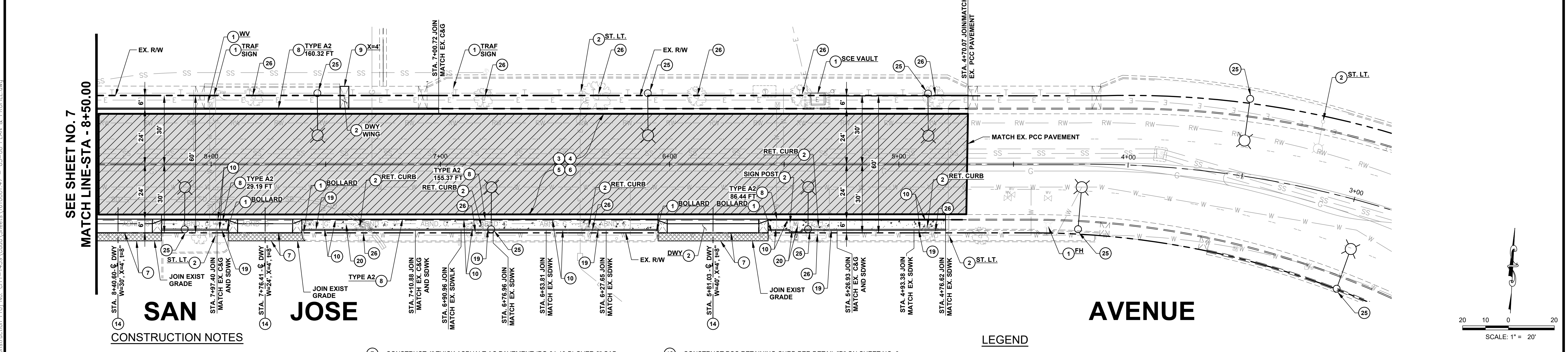
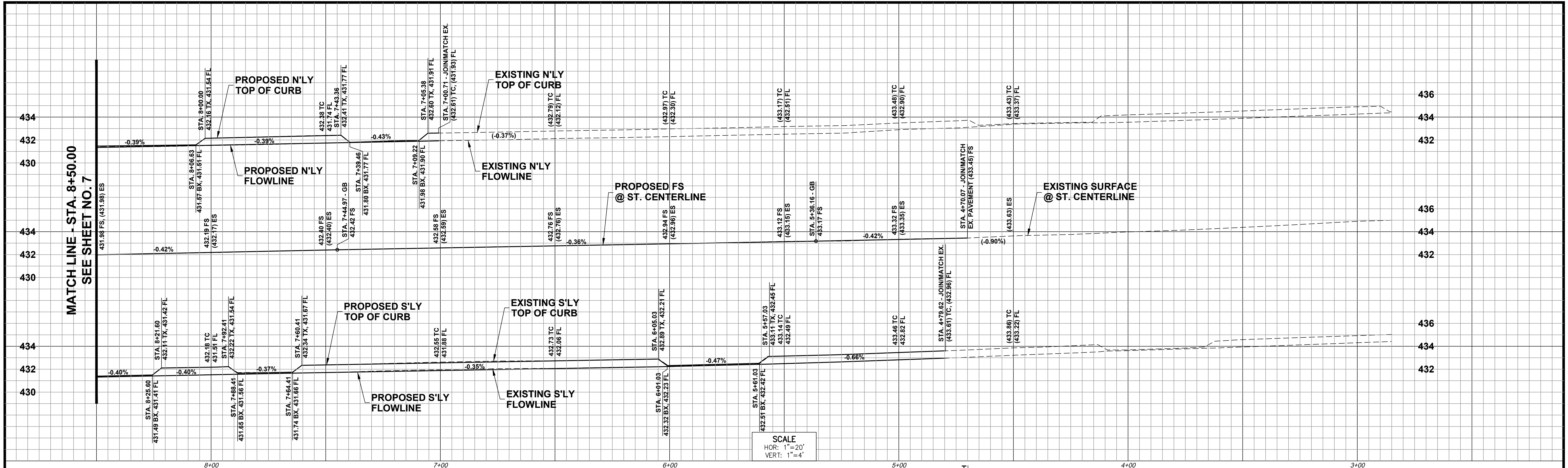

- CONSTRUCTION NOTES**
- 1 - PROTECT IN PLACE.
  - 2 - REMOVE ITEM PER PLAN.
  - 3 - REMOVE AND HAUL EXISTING AC PAVEMENT INCLUDING BASE 20" DEEP.
  - 4 - CONSTRUCT 13-1/2" CAB OVER 12" ENGINEERED FILL. INSTALL TWO LAYERS OF GEOGRID (TENSAR TX7-ONE), ONE LAYER AT BOTTOM OF CAB AND ONE LAYER AT 8" ABOVE SUBGRADE.
  - 5 - CONSTRUCT 4" THICK ASPHALT BASE COURSE (PG-64-10-B).
  - 6 - CONSTRUCT 2-1/2" THICK ASPHALT PAVEMENT SURFACE COURSE (PG 64-10-C).
  - 7 - CONSTRUCT 4" THICK ASPHALT AC PAVEMENT (PG-64-10-B) OVER 6" CAB AT THE BACK OF PROPOSED DRIVEWAY.
  - 8 - CONSTRUCT CURB AND GUTTER PER CITY OF INDUSTRY STD. PLAN NO. 112, TYPE PER PLAN, INCLUDING CRUSHED AGG. BASE.
  - 9 - CONSTRUCT DRIVEWAY PER CITY OF INDUSTRY STD. PLAN NO. 114, INCLUDING CRUSHED AGG. BASE. WIDTH(W) PER PLAN.
  - 10 - CONSTRUCT PCC SIDEWALK PER CITY OF INDUSTRY STD. PLAN NO. 115, INCLUDING CRUSHED AGG. BASE.
  - 14 - CONSTRUCT MODIFIED DRIVEWAY APPROACH PER SPPWC STD. PLAN NO. 110-2, TYPE B, AND PER DETAIL "A" ON SHEET NO. 3, INCLUDING CRUSHED AGG. BASE, WIDTH(W), WING(X), AND THICKNESS(T) PER PLAN.
  - 19 - CONSTRUCT PCC RETAINING CURB PER DETAIL "D" ON SHEET NO. 3
  - 20 - WATER STRUCTURE/FIRE HYDRANT/AIR VENTS/WATER METERS BOXES TO BE ADJUSTED/REMOVED/RELOCATED/INSTALLED BY ROWLAND WATER DISTRICT.
  - 25 - PROPOSED STREET LIGHT. SEE STREET LIGHT PLANS.
  - 26 - REMOVE EXISTING TREE. SEE LANDSCAPE PLANS

- LEGEND**
- 2-1/2" ASPHALT PAVEMENT (PG 64-10-C)
  - 4" BASE PAVEMENT (PG 64-10-B)
  - 4" AC PAVEMENT (PG-64-10-B) OVER 6" CAB.

**BENCHMARK**  
 B.M. CH-1 ELEV. 428.357 FT.  
 1-3/8" BRASS CAP MONUMENT ON TOP OF WEST CURB CHARLIE ROAD 60'± NORTH OF RAILROAD ST. (2'± NORTH OF BCR)  
 INDUSTRY, CA

NO.	DATE	REVISIONS	OK BY



**CITY OF INDUSTRY**  
 INCORPORATED JUNE 18, 1957  
 P.O. Box 3366, City of Industry, California 91744  
 Administrative Offices: 15625 Mayor Dave Way (626) 333-2211

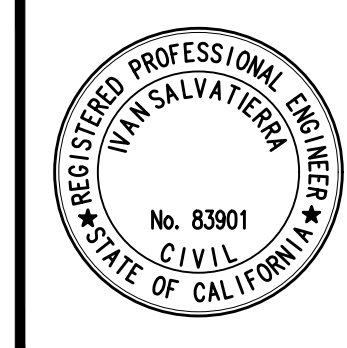

Plans Prepared by:  
**JMD**  
 PLANNING | ENGINEERING | MANAGEMENT  
 18645 East Gate Avenue, Suite 212  
 City of Industry, CA 91748  
 (626) 800-1137 Tel  
 (626) 800-1138 Fax  
 www.jmdaz.com  
 UNDER THE SUPERVISION OF:  
 Ivan Salvatierra RCE 83901  
 5/12/2022  
 DATE

**CITY OF INDUSTRY**  
 CLEMENT N. CALVILLO, PE, RCE 27743 DEPUTY CITY ENGINEER DATE

**SAN JOSE AVENUE RECONSTRUCTION**  
 STREET IMPROVEMENTS  
 SAN JOSE AVENUE  
 PLAN AND PROFILE  
 FROM STA. 4+70.07 TO STA. 8+50.00

DESIGNED BY: D.D CHECKED BY: D.S JOB NO. MP08-09 SHEET 8 OF 9  
 DRAFTED BY: D.H DATE: 09/15/2021 CONTRACT NO. CITY-1439

CONTRACT DRAWING OF

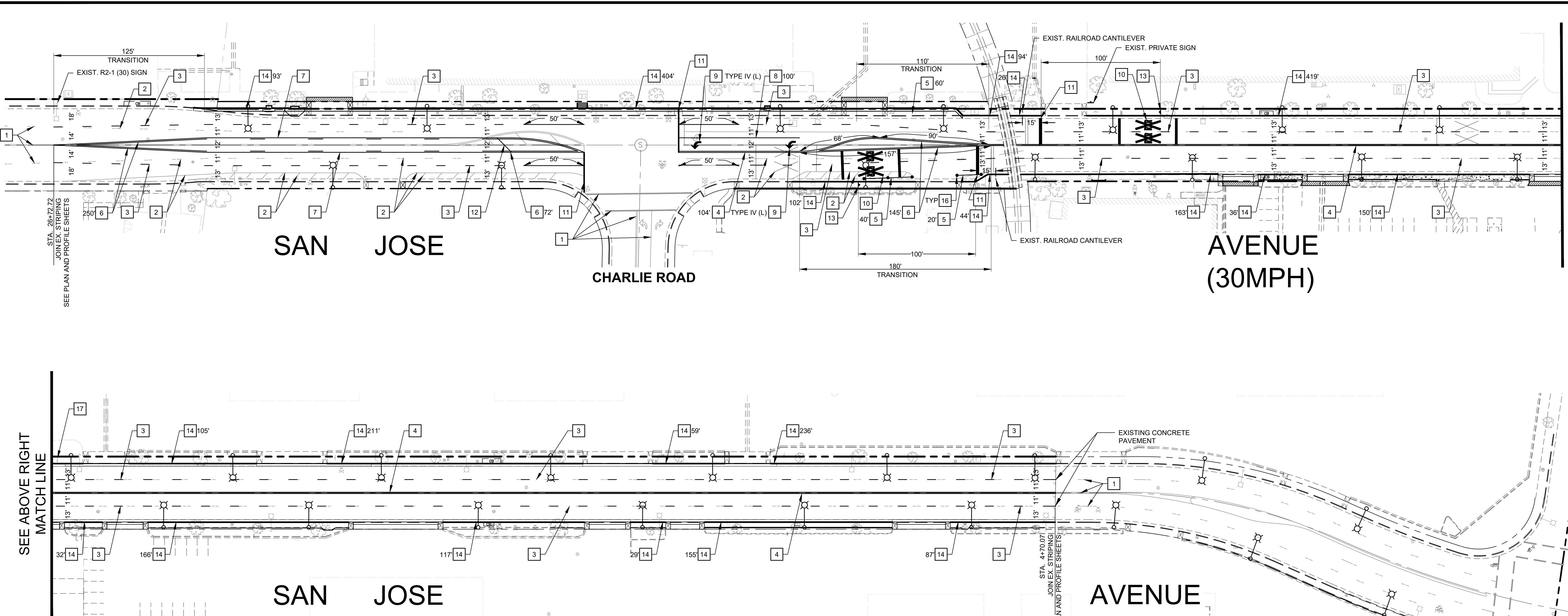

MATCH LINE  
SEE BELOW LEFT

SEE ABOVE RIGHT  
MATCH LINE

SAN JOSE

CHARLIE ROAD

AVENUE  
(30MPH)

SAN JOSE

AVENUE  
(30MPH)

NOGALES STREET

**SIGNING AND STRIPING NOTES**

- 1 - PROTECT EXISTING STRIPING/LEGEND IN PLACE.
- 2 - REMOVE STRIPING AND MARKING BY WET SANDBLASTING.
- 3 - INSTALL 6-INCH WHITE LANE LINE PER CALTRANS STD. PLAN NO. A20A, DETAIL 9.
- 4 - INSTALL 6-INCH DOUBLE YELLOW PER CALTRANS STD. PLAN NO. A20A, DETAIL 22.
- 5 - INSTALL 6-INCH WHITE EDGELINE PER CALTRANS STD. PLAN NO. A20B, DETAIL 27B.
- 6 - INSTALL 6-INCH DOUBLE YELLOW MEDIAN ISLAND PER CALTRANS STD. PLAN NO. A20B, DETAIL 29.
- 7 - INSTALL TWO-WAY LEFT TURN LANE PER CALTRANS STD. PLAN NO. A20B, DETAIL 32.
- 8 - INSTALL 8-INCH SOLID WHITE CHANNELIZING LINE PER CALTRANS STD. PLAN NO. A20D, DETAIL 38.
- 9 - INSTALL PAVEMENT MARKING ARROWS PER CALTRANS REVISED STD. PLAN NO. A24A. TYPE PER PLAN.
- 10 - INSTALL PAVEMENT LEGEND PER CALTRANS STD. PLAN NO. A24B.
- 11 - INSTALL 24-INCH WIDE SOLID WHITE LIMIT LINE SET 15-FEET FROM RAILROAD CANTILEVER CENTER OF POLE.
- 12 - INSTALL 12-INCH YELLOW DIAGONAL LINE.
- 13 - INSTALL W10-1 SIGN AND POST.
- 14 - PAINT CURB "RED". (LENGTH AS INDICATED)
- 15 - INSTALL 12-INCH WHITE LINE.
- 16 - INSTALL SURFACE MOUNTED WHITE CHANNELIZER WITH WHITE RETROREFLECTIVE SHEETING PER CALTRANS STD. PLAN NO. A73C AS SHOWN ON PLAN.
- 17 - REMOVE EXISTING SIGN AND POST

**LEGEND**

- PAVEMENT CHANNELIZER
- W10-1
- EX TRAFFIC SIGNAL

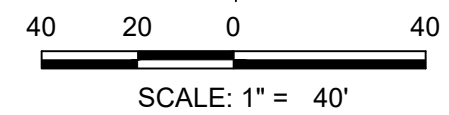

**BENCHMARK**  
B.M. CH-1 ELEV. 428.357 FT.  
1-3/8" BRASS CAP MONUMENT ON TOP OF WEST CURB CHARLIE ROAD 60'± NORTH OF RAILROAD ST. (2'± NORTH OF BCR)  
INDUSTRY, CA

NO.	DATE	REVISIONS	OK. BY



**CITY OF INDUSTRY**  
INCORPORATED JUNE 18, 1957  
P.O. Box 3366, City of Industry, California 91744  
Administrative Offices: 15625 Mayor Dave Way (626) 333-2211

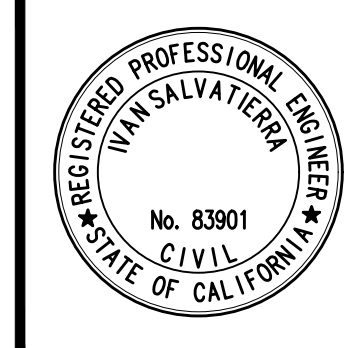

Plans Prepared by:  
**JMD**  
PLANNING | ENGINEERING | MANAGEMENT  
18645 East Gale Avenue, Suite 212  
City of Industry, CA 91748  
(626) 800-1137 Tel  
(626) 800-1138 Fax  
www.jmdaz.com  
UNDER THE SUPERVISION OF:  
IVAN SALVATIERRA RCE 83901 DATE: 5/12/2022

**CITY OF INDUSTRY**  
CLEMENT N. CALVILLO, PE, RCE 27743 DEPUTY CITY ENGINEER DATE: \_\_\_\_\_  
**SAN JOSE AVENUE RECONSTRUCTION**  
STREET IMPROVEMENTS  
SAN JOSE AVENUE  
SIGNING AND STRIPING PLAN  
DESIGNED BY: D.D CHECKED BY: D.S JOB NO. MP08-09  
DRAFTED BY: D.H DATE: 09/15/2021 CONTRACT NO. CITY-1439 SHEET 9 OF 9  
CONTRACT DRAWING OF

# CITY OF INDUSTRY IMPROVEMENT PROJECT NO. 1439 SAN JOSE AVENUE RECONSTRUCTION FROM CHARLIE ROAD TO NOGALES STREET STREET LIGHTING PLAN

## GENERAL NOTES

- UNLESS OTHERWISE NOTED, ALL WORK SHALL BE DONE IN ACCORDANCE WITH THE STANDARD SPECIFICATIONS FOR PUBLIC WORKS CONSTRUCTION, CURRENT EDITION WITH ALL CURRENT SUPPLEMENTS, PUBLISHED BY BUILDING NEWS INC., LOCATED AT 900 PARK CENTER DRIVE, SUITE E, VISTA, CA 92081 AND APPROPRIATE STANDARD DRAWINGS.
- PRIOR TO BEGINNING OF ANY WORK, OBTAIN A PERMIT FROM THE CITY OF INDUSTRY, 15625 MAYOR DAVE WAY, CITY OF INDUSTRY, CA 91744, (626) 333-2211, IF REQUIRED.
- ALL WORK COVERED BY THIS PLAN SHALL BE INSPECTED BY THE CITY ENGINEER. REQUEST FOR INSPECTION SERVICE SHALL BE MADE 48-HOURS IN ADVANCE AT (818) 333-0336.
- STREET IMPROVEMENT CONSTRUCTION SHALL BE DONE ACCORDING TO THE STANDARD PLANS, LATEST EDITION, OF THE CITY OF INDUSTRY, AVAILABLE AT THE OFFICE OF THE CITY ENGINEER AT 15625 MAYOR DAVE WAY, CITY OF INDUSTRY, CA. 91744.
- WORK IN EXISTING STREETS SHALL BE COMPLETED AS SOON AS POSSIBLE TO MINIMIZE INCONVENIENCE TO ADJACENT PROPERTY OWNERS AND THE TRAVELING PUBLIC. FAILURE TO COMPLY WITH THIS REQUIREMENT IS A VIOLATION OF CITY ORDINANCE.
- THE CONTRACTOR SHALL NOTIFY THE LOS ANGELES COUNTY FIRE DEPARTMENT (818) 963-2417 AND THE LOS ANGELES SHERIFF DEPARTMENT (818) 330-3322 AT THE CITY OF INDUSTRY SUBSTATION AT LEAST 48-HOURS PRIOR TO START OF WORK.
- ALL UTILITY TRENCHES IN PUBLIC STREETS OR FUTURE PUBLIC STREETS SHALL BE BACKFILLED WITH A CLEAN GRANULAR MATERIAL HAVING A MINIMUM SAND EQUIVALENT OF 30. BACKFILL SHALL BE COMPACTED TO A MINIMUM RELATIVE DENSITY OF 90 PERCENT, UP TO 6" BELOW FINAL GRADE AND AT LEAST 95% AT UPPER 6" OF FINAL GRADE.
- THE OPTION OF USING SLAG OR CRUSHED MISC. BASE (CMB) IN LIEU OF CRUSHED AGGREGATE BASE FOR ANY STREET IMPROVEMENT IS NOT ALLOWED.
- EXISTING CONCRETE IMPROVEMENTS AND ASPHALT CONCRETE PAVEMENT SHALL BE SAW CUT, FULL DEPTH, TO A TRUE LINE WHERE NEW CONCRETE OR ASPHALT IS TO JOIN.
- ALL MANHOLES SHALL BE ADJUSTED TO FINISHED GRADE IN ACCORDANCE WITH SECTION 403 OF THE STANDARD SPECIFICATIONS. CONTRACTOR SHALL NOTIFY COUNTY SANITATION DISTRICT OF LOS ANGELES COUNTY (CSD), SUPERINTENDENT OF MAINTENANCE AT (213) 774-7272 A MINIMUM OF 48 HOURS PRIOR TO THE COMMENCEMENT OF ANY WORK IN THE AREA OF THEIR MANHOLES. CONTRACTOR SHALL ASSIST IN THE ADJUSTMENT OF MANHOLES IN ACCORDANCE WITH THEIR PROCEDURES, LATEST EDITION.
- THE CONTRACTOR SHALL PROTECT AND RESTORE EXISTING UTILITIES AND IMPROVEMENTS AS PER SECTION 400, 402-1 AND 402-2 OF THE STANDARD SPECIFICATIONS FOR PUBLIC WORKS CONSTRUCTION.
- IT SHALL BE THE RESPONSIBILITY OF THE CONTRACTOR TO LOCATE ALL UTILITIES OF EVERY NATURE WHETHER SHOWN HEREON OR NOT TO PROTECT THEM FROM DAMAGE. THE CONTRACTOR SHALL BEAR THE TOTAL EXPENSE OF REPAIR OR REPLACEMENT OF SAID UTILITIES DAMAGED BY OPERATIONS IN CONNECTION WITH THE PROSECUTION OF THE WORK.
- 48-HOURS PRIOR TO ANY STREET WORK, THE CONTRACTOR SHALL CALL THE UNDERGROUND SERVICE ALERT AT 1 (800) 422-4133 AND OBTAIN AN INQUIRY IDENTIFICATION NUMBER.
- THE FOLLOWING IS A LIST OF THE UTILITY COMPANIES AND THE PERSONS TO CONTACT REGARDING THE RESPECTIVE UTILITIES WITHIN THE LIMITS OF THIS PROJECT:
 

MR. AMIN ABULEHOUDA FRONTIER CALIFORNIA, INC.	(909) 649-6369
MR. MICHAEL COVARRUBIAS SOUTHERN CALIFORNIA GAS COMPANY	(714) 634-7260
MR. MIKE HOWARD (DISTRIBUTION) CALIFORNIA EDISON COMPANY	(909) 592-3725
MR. JOHN POEHLER ROWLAND WATER DISTRICT	(562) 697-1726
MR. ANTHONY HOWARD SANITATION DISTRICT OF L.A. COUNTY	(562) 908-4288
MR. MICHAEL BYRD SOUTHERN CALIFORNIA EDISON	(909) 592-3725
- ANY CONTRACTOR OR SUBCONTRACTOR PERFORMING WORK ON THIS PROJECT SHALL FAMILIARIZE THEMSELVES WITH THE SITE AND SHALL BE SOLELY RESPONSIBLE FOR ANY DAMAGE TO EXISTING FACILITIES RESULTING DIRECTLY OR INDIRECTLY FROM THEIR OPERATIONS, WHETHER OR NOT SUCH FACILITIES ARE SHOWN ON THESE PLAN

## CONSTRUCTION NOTES

- PROTECT IN PLACE, DESCRIPTION PER PLAN.
- FURNISH AND INSTALL AMERON CONCRETE POLE, MODEL 1C128 PLUS ANTI-GRAFFITI COATING WITH 12' MASTARM OR APPROVED EQUAL, PER DETAIL NO. 1 ON SHEET 3 AND INSTALL COI STREETLIGHT POLE NUMBER ON THE POLE (NUMBERING MATERIAL IS PROVIDED BY CITY).
- FURNISH AND INSTALL TYPE-III 4000K 110-WATT LED LUMINAIRE COOPER # ARCH-L-PA3-110-740-U-T3-AP-10MSP-PR7-10X OR APPROVED EQUAL WITH WIRELESS REMOTE MONITORING CONTROLLER (NODE IS PROVIDED BY CITY), UBICQUA CAT. NO. UBC-30-01-01-NA-01-1GY (SEE SPECIFICATION FOR NODE INSTALLATION REQUIREMENTS).
- FURNISH AND INSTALL NO. 5 PULL BOX JENSEN CAT. NO. CYN20 OR EQUAL FOR BOX AND JENSEN CAT. NO. CYN16-61J OR EQUAL FOR COVER WITH "COI ST LIGHT" MARKED ON COVER PER CALTRANS STD PLAN NO. RSP ES-8A AND DETAIL 2A OR 2B ON SHEET 3. PULL BOX TO HAVE 10-AMP IN-LINE FUSE IN FUSE HOLDER BUSSMANN KTK-10 LIMITRON. FOR EACH STREET LIGHT.
- CONSTRUCT 3" PVC SCH 40 STREET LIGHT CONDUIT, MINIMUM 30" DEEP BETWEEN PULLBOXES AND 1" PVC SCH 40 BETWEEN EACH PULLBOX AND STREET LIGHT POLE INCLUDING TRENCHING AND COMPACTION PER DETAIL 2A OR 2B ON SHEET 3.
- FURNISH AND INSTALL 2-1/0 STRANDED AL XHHW AND 1-#2 STRANDED AL XHHW WIRE IN CONDUIT BETWEEN PULLBOXES AND 2-#6 AL XHHW BETWEEN PULL BOX AND STREET LIGHT POLES AND UP TO LUMINAIRE AT THE TOP OF POLE.
- FURNISH AND INSTALL 200A, SS304 METERING ENCLOSURE TYPE 3R, RAINPROOF 120/240V, 1ø, 3/WIRE WITH PROVISION FOR METER AND TEST BLOCKS METER SERVICE PEDESTAL STRONGBOX MODEL: CSP-12016-10 OR APPROVED EQUAL.
- RESTORE THE SIDEWALK PER CITY OF INDUSTRY STD PLAN 115 AND STREET PER CITY OF INDUSTRY STD PLAN 111 IN THE NORMAL CONDITION AFTER THE CONSTRUCTION IS COMPLETED, AS REQUIRED.
- CONTRACTOR TO REMOVE EXISTING STREET LIGHT POLES AND LUMINAIRES AND TRANSPORT TO HATCHER YARD AT 1123 N. HATCHER AVENUE AND REMOVE FOUNDATIONS.
- SCE TO DE-ENERGIZED POWER SOURCE FOR STREET LIGHTS AND REMOVE ALL UNDERGROUND CABLE AND ABANDON EXISTING CONDUIT TO EXISTING POLES AND PULLBOXES IN PLACE.
- CONDUIT FROM SCE VAULT TO NO. 6 PULLBOX AND TO METERING SERVICE PEDESTAL TO BE 3" PVC SCHEDULE 80 MIN. 30" DEEP. SERVICE CABLE FROM SCE VAULT TO LINE SIDE OF METERING SERVICE PANEL BY SCE INCLUDING METER.
- FURNISH AND INSTALL 3" PVC SCH 80 CONDUIT FOR TWO STREET CROSSINGS, MINIMUM 48" DEEP.

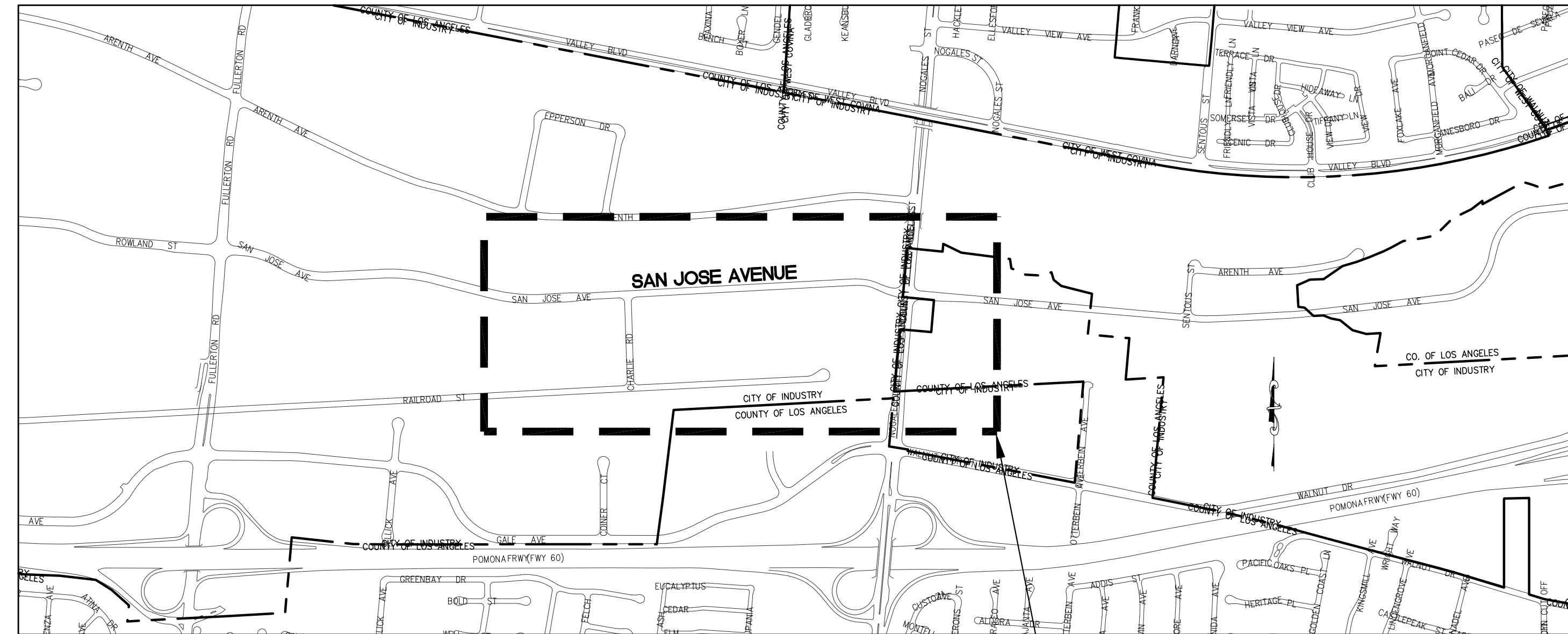

VICINITY MAP  
NOT TO SCALE

PROJECT SITE

## INDEX OF DRAWINGS

CONTRACT DWG NO.	SHEET NO.	DESCRIPTION
10 OF 22	1 OF 4	TITLE SHEET: VICINITY MAP, GENERAL NOTES, CONSTRUCTION NOTES, INDEX OF DRAWINGS, NOTICE TO CONTRACTOR, LEGEND AND ABBREVIATIONS
11 OF 22	2 OF 4	STREET LIGHTING AND FIBER OPTIC PLAN
12 OF 22	3 OF 4	DETAILS AND GENERAL NOTES
13 OF 22	4 OF 4	SCE SERVICE DETAIL AND WIRING DIAGRAM

## LEGEND

- |   |  |
|---|--|
| <ul style="list-style-type: none"> <li> EX POWER POLE</li> <li> EX TEL POLE</li> <li> EX SIGN</li> <li> EX PULL BOX</li> <li> EX CATCH BASIN</li> <li> EX FIRE HYDRANT</li> <li> EX WATER VALVE</li> <li> EX GAS VALVE</li> <li> EX SEWER MANHOLE</li> <li> EX DRAIN MANHOLE</li> <li> EX TELEPHONE MANHOLE</li> <li> EX DRIVEWAY</li> <li> PROP DRIVEWAY</li> <li> PROP C&amp;G</li> <li> PROP CHAIN LINK FENCE</li> </ul> | <ul style="list-style-type: none"> <li> EX TRAFFIC SIGNAL WITH LUMINAIRE</li> <li> EX TRAFFIC SIGNAL</li> <li> EX STREET LIGHT</li> <li> PROP JOINT PLANE CONCRETE PAVEMENT</li> <li> COLDMILL AND OVERLAY</li> <li> TO BE ADJUSTED BY SCE</li> <li> PROTECT IN PLACE</li> <li> TO BE ADJUSTED BY FRONTIER CALIFORNIA, INC.</li> <li> TO BE RESTORED BY LACDPW</li> <li> TO BE ADJUSTED BY ROWLAND WATER DISTRICT</li> </ul> |
|---|--|

## ABBREVIATIONS

AC ASPHALT CONCRETE	L LEFT
BCR BEGIN CURVE RETURN	LE LENGTH
BW BACK OF WALK	LACDPW LOS ANGELES COUNTY DEPARTMENT OF PUBLIC WORKS
C&G CURB AND GUTTER	MH MANHOLE
CB CATCH BASIN	NG NATURAL GROUND
CF CURB FACE	PROP PROPOSED
CLF CHAINLINK FENCE	PVMT PAVEMENT
CL CENTERLINE	R RIGHT
CONST CONSTRUCTION	RCP REINFORCED CONCRETE PIPE
CSD COUNTY STORM DRAIN	R/W RIGHT OF WAY
DWY DRIVEWAY	SCE SOUTHERN CALIFORNIA EDISON
ECR END CURVE RETURN	SD STORM DRAIN
EG EXISTING GRADE, EDGE OF GUTTER	SPPWC STANDARD PLANS FOR PUBLIC WORKS CONSTRUCTION
ELEC ELECTRICAL	SS SANITARY SEWER
EP EDGE OF PAVEMENT	STD STANDARD
EX/EXIST EXISTING	SW PCC SIDEWALK
FL FLOW LINE	TC TOP OF CURB
FS FINISHED SURFACE	TX TOP OF CURB AT BOTTOM OF RAMP
GB GRADE BREAK	(XXX.X) EXISTING ELEVATION
GP HIGH POINT	
J-PCP JOINTED PLAIN CONCRETE PAVEMENT	

## NOTICE TO CONTRACTOR

APPROVAL OF THIS PLAN BY THE ENGINEER AND CITY ENGINEER DOES NOT CONSTITUTE A REPRESENTATION AS TO THE ACCURACY OF THE LOCATION OF OR THE EXISTENCE OR NON-EXISTENCE OF ANY UNDERGROUND UTILITY PIPE OR STRUCTURE WITHIN THE LIMITS OF THIS PROJECT. THE EXISTENCE AND LOCATION OF ANY UNDERGROUND UTILITY PIPES OR STRUCTURES SHOWN ON THESE PLANS WERE OBTAINED BY A SEARCH OF AVAILABLE RECORDS.

**BENCHMARK**  
B.M. X-XX ELEV. X-XX  
XXXXXXXXXXXXXXXX  
XXXXXXXXXXXXXXXX  
XXXXXXXXXXXXXXXX



NO.	DATE	REVISIONS	CHK. BY



**CITY OF INDUSTRY**

INCORPORATED JUNE 18, 1957  
P.O. Box 3366, City of Industry, California 91744  
Administrative Offices: 15625 Mayor Dave Way  
(626) 333-2211

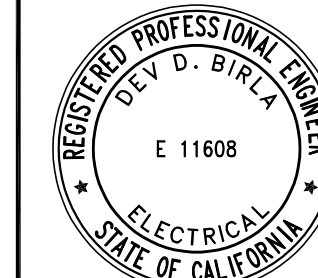

Prepared by:  
**ACNC ENGINEERING**  
255 N Hacienda Blvd | Ste 222  
City of Industry | CA | 91744  
P | 626.333.0336  
www.cnc-eng.com  
DEV D. BILRA, P.E. 11608 DATE

## CITY OF INDUSTRY

APPROVED BY:		DATE	
CLEMENT N. CALVILLO, PE, RCE 27743 DEPUTY CITY ENGINEER	JOSHUA L. NELSON, PE, RCE 66959 CITY MANAGER	DATE	DATE
<b>SAN JOSE AVENUE RECONSTRUCTION FROM CHARLIE ROAD TO NOGALES STREET</b>			
<b>TITLE SHEET: VICINITY MAP, GENERAL NOTES, CONSTRUCTION NOTES, INDEX OF DRAWINGS, NOTICE TO CONTRACTOR, LEGEND AND ABBREVIATION</b>			
DESIGNED BY: D.B.	CHECKED BY: J.C.	JOB NO. MP 08-09	SHEET 1 OF 4
DRAFTED BY: E.C.	DATE: FEB 2022	CONTRACT NO. CITY-1439	

CONTRACT DRAWING OF

K:\Misc\0809 San Jose Ave Reconstruction - Railroad Street\Street Lighting Plan - San Jose Ave CNC\Sheet\MP0809 San Jose ST LT 02 Plan v2.dwg  
2/28/2025 11:08 AM

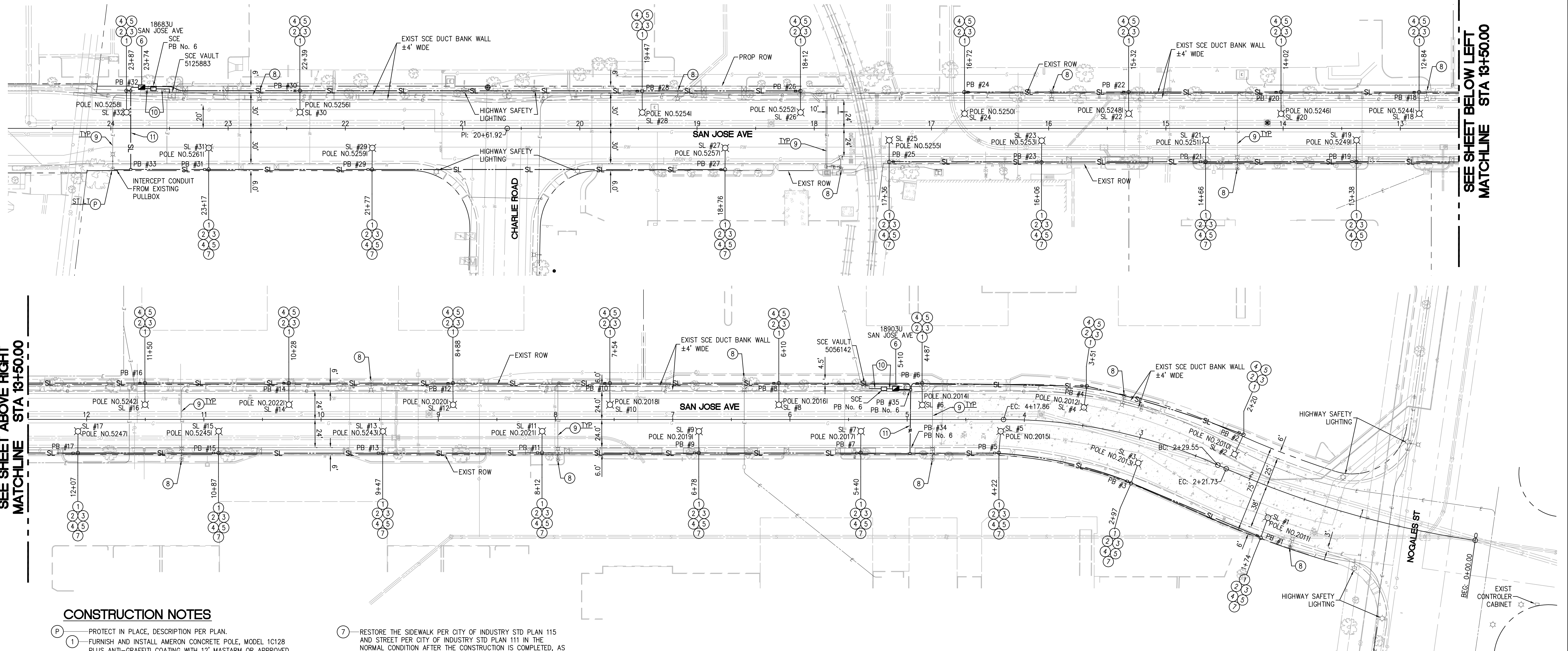

SEE SHEET ABOVE RIGHT  
MATCHLINE STA 13+50.00

SEE SHEET BELOW LEFT  
MATCHLINE STA 13+50.00

**CONSTRUCTION NOTES**

- (P) PROTECT IN PLACE, DESCRIPTION PER PLAN.
- (1) FURNISH AND INSTALL AMERON CONCRETE POLE, MODEL 1C128 PLUS ANTI-GRAFFITI COATING WITH 12" MASTARM OR APPROVED EQUAL, PER DETAIL NO. 1 ON SHEET 3 AND INSTALL COI STREETLIGHT POLE NUMBER ON THE POLE (NUMBERING MATERIAL IS PROVIDED BY CITY).
- (2) FURNISH AND INSTALL TYPE-III 4000K 110-WATT LED LUMINAIRE COOPER # ARCH-L-PA3-110-740-U-T3-AP-10MSP-PR7-10X OR APPROVED EQUAL WITH WIRELESS REMOTE MONITORING CONTROLLER (NODE IS PROVIDED BY CITY), UBICQUIA CAT. NO. UBC-30-01-01-NA-01-1GY (SEE SPECIFICATION FOR NODE INSTALLATION REQUIREMENTS).
- (3) FURNISH AND INSTALL NO. 5 PULL BOX JENSEN CAT. NO. CYN20 OR EQUAL FOR BOX AND JENSEN CAT. NO. CYN16-61J OR EQUAL FOR COVER WITH "COI ST LIGHT" MARKED ON COVER PER CALTRANS STD PLAN NO. RSP ES-8A AND DETAIL 2A OR 2B ON SHEET 3. PULL BOX TO HAVE 10-AMP IN-LINE FUSE IN FUSE HOLDER BUSSMANN KTK-10 LIMITRON. FOR EACH STREET LIGHT.
- (4) CONSTRUCT 3" PVC SCH 40 STREET LIGHT CONDUIT, MINIMUM 30" DEEP BETWEEN PULLBOXES AND 1" PVC SCH 40 BETWEEN EACH PULLBOX AND STREET LIGHT POLE INCLUDING TRENCHING AND COMPACTION PER DETAIL 2A OR 2B ON SHEET 3.
- (5) FURNISH AND INSTALL 2-1/0 STRANDED AL XHHW AND 1-#2 STRANDED AL XHHW WIRE IN CONDUIT BETWEEN PULLBOXES AND 2-#6 AL XHHW BETWEEN PULL BOX AND STREET LIGHT POLES AND UP TO LUMINAIRE AT THE TOP OF POLE.
- (6) FURNISH AND INSTALL 200A, SS304 METERING ENCLOSURE TYPE 3R, RAINPROOF 120/240V, 1Ø, 3/WIRE WITH PROVISION FOR METER AND TEST BLOCKS METER SERVICE PEDESTAL STRONGBOX MODEL: CSP-12016-10 OR APPROVED EQUAL.
- (7) RESTORE THE SIDEWALK PER CITY OF INDUSTRY STD PLAN 115 AND STREET PER CITY OF INDUSTRY STD PLAN 111 IN THE NORMAL CONDITION AFTER THE CONSTRUCTION IS COMPLETED, AS REQUIRED.
- (8) CONTRACTOR TO REMOVE EXISTING STREET LIGHT POLES AND LUMINAIRES AND TRANSPORT TO HATCHER YARD AT 1123 N. HATCHER AVENUE AND REMOVE FOUNDATIONS.
- (9) SCE TO DE-ENERGIZED POWER SOURCE FOR STREET LIGHTS AND REMOVE ALL UNDERGROUND CABLE AND ABANDON EXISTING CONDUIT TO EXISTING POLES AND PULLBOXES IN PLACE.
- (10) CONDUIT FROM SCE VAULT TO NO. 6 PULLBOX AND TO METERING SERVICE PEDESTAL TO BE 3" PVC SCHEDULE 80 MIN. 30" DEEP. SERVICE CABLE FROM SCE VAULT TO LINE SIDE OF METERING SERVICE PANEL BY SCE INCLUDING METER.
- (11) FURNISH AND INSTALL 3" PVC SCH 80 CONDUIT FOR TWO STREET CROSSINGS, MINIMUM 48" DEEP.

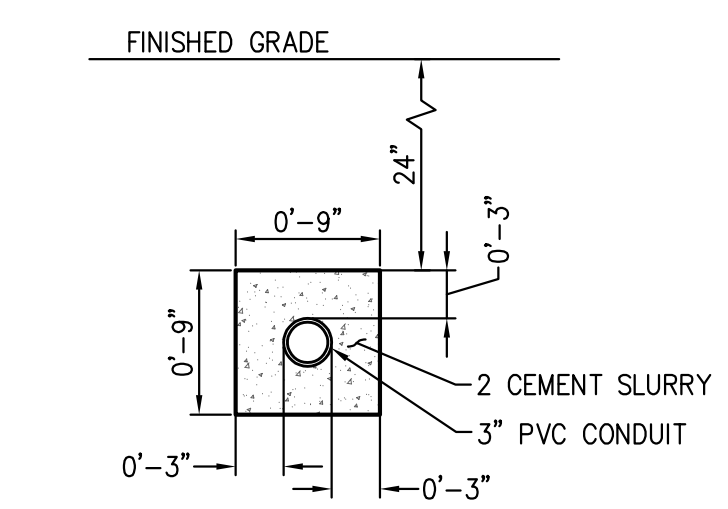

**SECTION 'A-A'**  
FIBER OPTIC CONDUIT DUCT BANK  
NOT TO SCALE

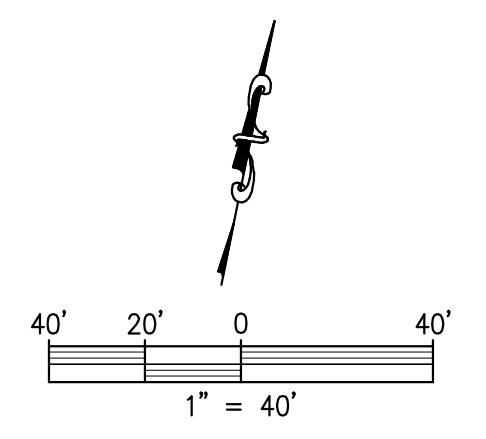

**BENCHMARK**  
B.M. X-XX ELEV. X-XX  
XXXXXXXXXXXXXXXX  
XXXXXXXXXXXXXXXX  
XXXXXXXXXXXXXXXX

**Underground Service Alert of Southern California**  
Call: TOLL FREE  
**1-800-227-2600**  
or 811  
**TWO WORKING DAYS BEFORE YOU DIG**

NO.	DATE	REVISIONS	CK. BY

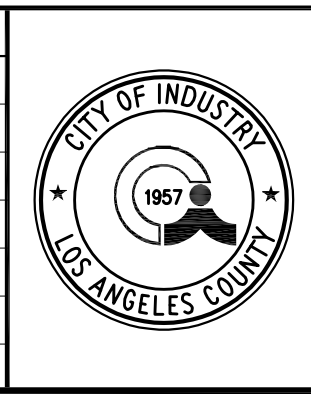

**CITY OF INDUSTRY**  
INCORPORATED JUNE 18, 1957  
P.O. Box 3366, City of Industry, California 91744  
Administrative Offices: 15625 Mayor Dave Way (626) 333-2211

Prepared by:  
**ACNC ENGINEERING**  
255 N Hacienda Blvd | Ste 222  
City of Industry | CA | 91744  
P | 626.333.0336  
www.cnc-eng.com  
DEV D. BILRA, P.E. 11608 DATE

**CITY OF INDUSTRY**  
APPROVED BY: \_\_\_\_\_ DATE: \_\_\_\_\_  
CLEMENT N. CALVILLO, PE, RCE 27743 DEPUTY CITY ENGINEER  
**SAN JOSE AVENUE RECONSTRUCTION  
FROM CHARLIE ROAD TO NOGALES STREET**  
**STREET LIGHTING AND  
FIBER OPTIC CONDUIT PLAN**  
DESIGNED BY: D.B. CHECKED BY: J.C. JOB NO. MP 08-09  
DRAFTED BY: E.C. DATE: FEB 2022 CONTRACT NO. CITY-1439 SHEET 2 OF 4  
CONTRACT DRAWING OF

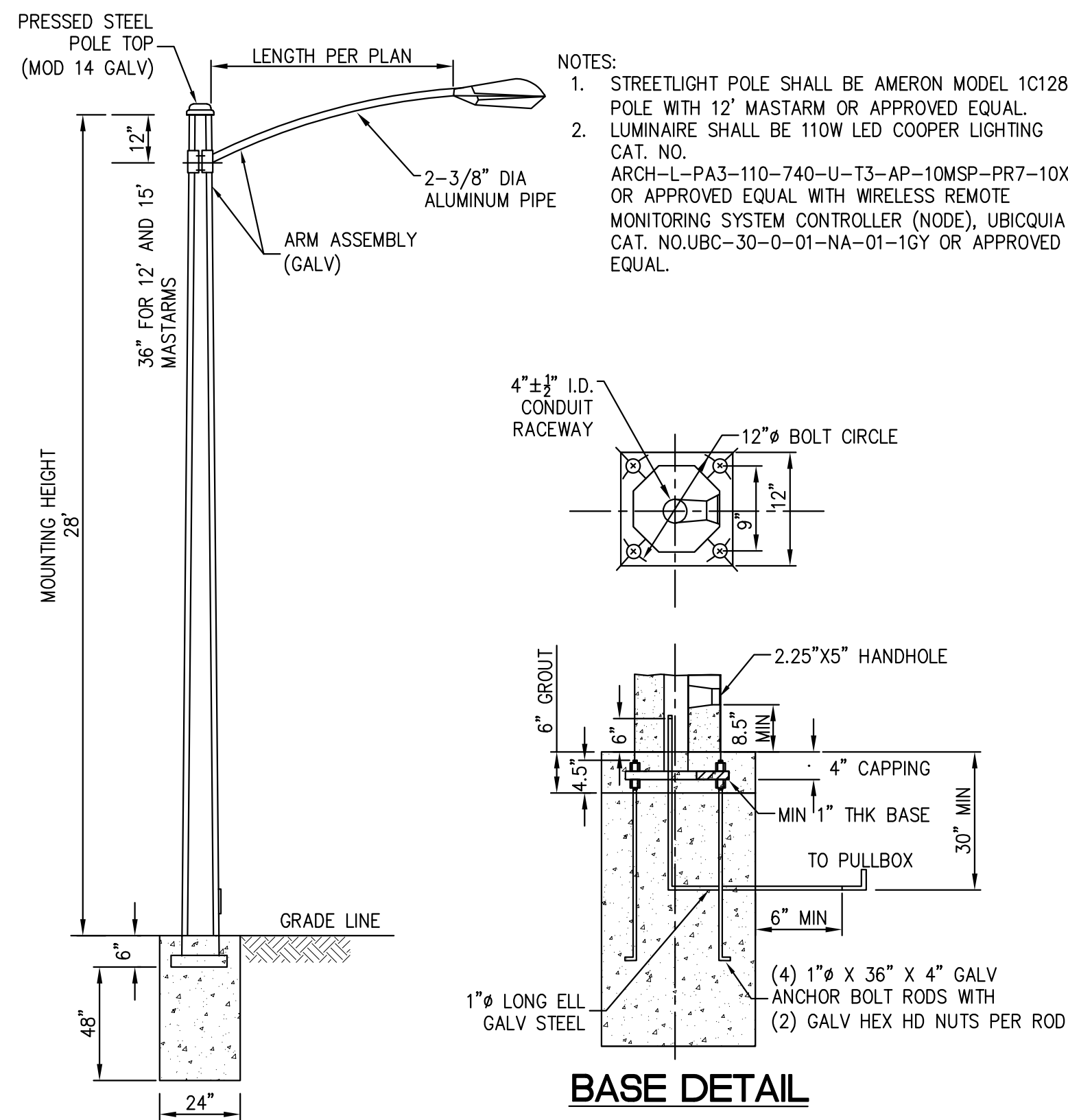

**1 TYPICAL AMERON STANDARD DETAILS**  
SCALE: N.T.S.

**GENERAL NOTES FOR STREET LIGHTING LAYOUT:**

- STREET LIGHT PLANS LAYOUT EXPIRES TWO YEARS AFTER THE LATEST DATE OF APPROVAL.
- THE LOCATION OF A STREET LIGHT POLE MAY BE ADJUSTED UP TO 10 FEET, TO AVOID AN OBSTRUCTION SUCH AS A CATCH BASIN, DRIVEWAY, ETC. ANY DEVIATION EXCEEDING 10 FEET MUST HAVE THE APPROVAL BY CITY ENGINEER.
- A REVISED STREET LIGHT PLAN SHALL BE SUBMITTED FOR ANY CHANGES IN THE MAP, SUCH AS STREET ALIGNMENT, LOT OR PARCEL SIZES, BOUNDARIES, ETC.
- ALL STREET LIGHT WIRING SHALL BE UNDERGROUND.
- CITY OPERATES AND MAINTAINS STREET LIGHT SYSTEM ON PUBLIC RIGHT-OF-WAY UNLESS OTHERWISE NOTED.
- ALL STREET LIGHT SYSTEM SHALL BE ENERGIZED PRIOR TO THE CITY'S ACCEPTANCE.
- STREET LIGHT POLES SHALL BE A MINIMUM OF FIVE (5) FEET FROM A FIRE HYDRANT.
- STREET LIGHT POLES SHALL BE A MINIMUM OF FIVE (5) FEET FROM TOP OF SLOPE A DRIVEWAY.
- THE STREET LIGHT POLES SHALL BE AMERON TYPE 1C1 SERIES WITH ANTI-GRAFFITI COATING OR APPROVED EQUAL.
- THE HEIGHT OF POLE AND LENGTH OF MAST ARM SHALL BE DETERMINED BY THE CITY ENGINEER.
- THE POLES SHALL BE PLUMB AND VERTICAL. MASTARMS SHALL BE INSTALLED PROJECTING IN A DIRECTION PERPENDICULAR TO THE CENTERLINE OF THE STREET OR TOWARDS THE CENTER OF THE CUL-DE-SAC. THE LUMINAIRE SHALL BE LEVELED WITH THE MASTARM AND SHALL BE PARALLEL TO THE STREET GRADE.
- THE STREET LIGHTING CONDUIT BETWEEN PULL BOXES SHALL BE 3-INCH PVC SCH 40 EXCEPT WITHIN THE ROADWAY.
- THE STREET LIGHTING CONDUIT BETWEEN PULL BOX AND STREET LIGHT POLE FOUNDATION SHALL BE 1" PVC SCH 40 CONDUIT.
- THE PROJECTING CONDUIT FROM THE STREET LIGHT STANDARD FOUNDATION SHALL BE CAPPED TO PREVENT DEBRIS FROM ENTERING CONDUIT DURING CONSTRUCTION.
- STREET LIGHT CONDUIT FROM POWER SOURCE TO SERVICE POINT SHALL BE COMPLETED BY THE CONTRACTOR.
- LUMINAIRES SHALL BE LIGHT EMITTING DIODE (LED), LUMINAIRE SIZE WILL BE DETERMINED BY THE CITY ENGINEER AND EQUIPPED WITH WIRELESS REMOTE MONITORING SYSTEM CONTROLLER UBICQUIA CAT NO. UBC-30-0-01-NA-01-1GY (NODE), CITY WILL PROVIDE THE NODE.
- THE STREET LIGHT CONDUCTORS BETWEEN PULL BOXES SHALL BE TWO 1/0 STRANDED AL AND ONE #2 STRANDED AL 600-VOLT XHHW, UNLESS SPECIFIED DIFFERENTLY.
- THE STREET LIGHT CONDUCTORS BETWEEN PULL BOX AND STREET LIGHT POLE FOUNDATION AND CONTINUING ALL THE WAY TO LUMINAIRES SHALL BE TWO #6 STRANDED AL 600-VOLT XHHW WITH 10-AMP IN-LINE FUSE IN FUSE HOLDER AT HANDHOLE OF STREET LIGHT POLE UNLESS SPECIFIED DIFFERENTLY.
- STREET LIGHT CONDUCTORS BETWEEN POWER SOURCE AND SERVICE POINT SHALL BE INSTALLED BY SCE OR IPU. STREET LIGHT CONDUCTORS BEYOND THE SERVICE POINT SHALL BE INSTALLED BY THE CONTRACTOR.
- CONDUCTORS SHALL BE SPLICED BY USE OF C-SHAPED COMPRESSION CONNECTOR OR THE PROPER SIZE OF SPLIT BOLT CONNECTORS.
- CONDUIT WITHIN THE STREET TO BE 3-INCH PVC SCH 40 MINIMUM 36" DEEP OF COVER WITH 2-SACK ENCASUREMENT OR 3-INCH PVC SCH 80 MINIMUM 48-INCH DEEP OF COVER. BASED ON FIELD CONDITIONS TO BE DETERMINED BY CITY ENGINEER. CONDUITS SHALL BE 3' FROM THE FACE OF CURB IF THERE ARE NO CONFLICT WITH ANY OTHER UTILITIES.
- PULL BOXES BEHIND EACH STREET LIGHT TO BE CALTRANS TRAFFIC RATED NO. 5 JENSEN CAT. NO. CYN20 OR APPROVED EQUAL FOR BOX AND JENSEN CAT. NO. CYN16-61J OR APPROVED EQUAL FOR COVER UNLESS SPECIFIED DIFFERENTLY.
- PULL BOXES SPECIFIED WITH NO. 6 PULLBOX ON THE PLAN SHALL BE CALTRANS TRAFFIC RATED NO.6 JENSEN CAT. NO. HT1730-B (BOX) AND JENSEN CAT. NO. HT1730-L11-01 (COVER) OR APPROVED EQUAL.
- CONTRACTOR TO POTHOLE LOCATIONS OF THE POLE FOUNDATIONS, THE PULL BOX AND CONDUIT RUNS BEFORE INSTALLATION TO CHECK FOR UTILITY CONFLICTS WITH AND NEAR ANY EXISTING UTILITY INFRASTRUCTURE OR AT ALL UTILITY CROSSINGS.
- UTILITY EASEMENTS MAY BE REQUIRED.
- THE CONCRETE MIX FOR THE STREET LIGHT POLE FOUNDATIONS SHALL BE 560-C-3250 AND THE CAPPING SHALL BE 520-C-2500 PER THE GREENBOOK AND PROJECT SPECIFICATIONS

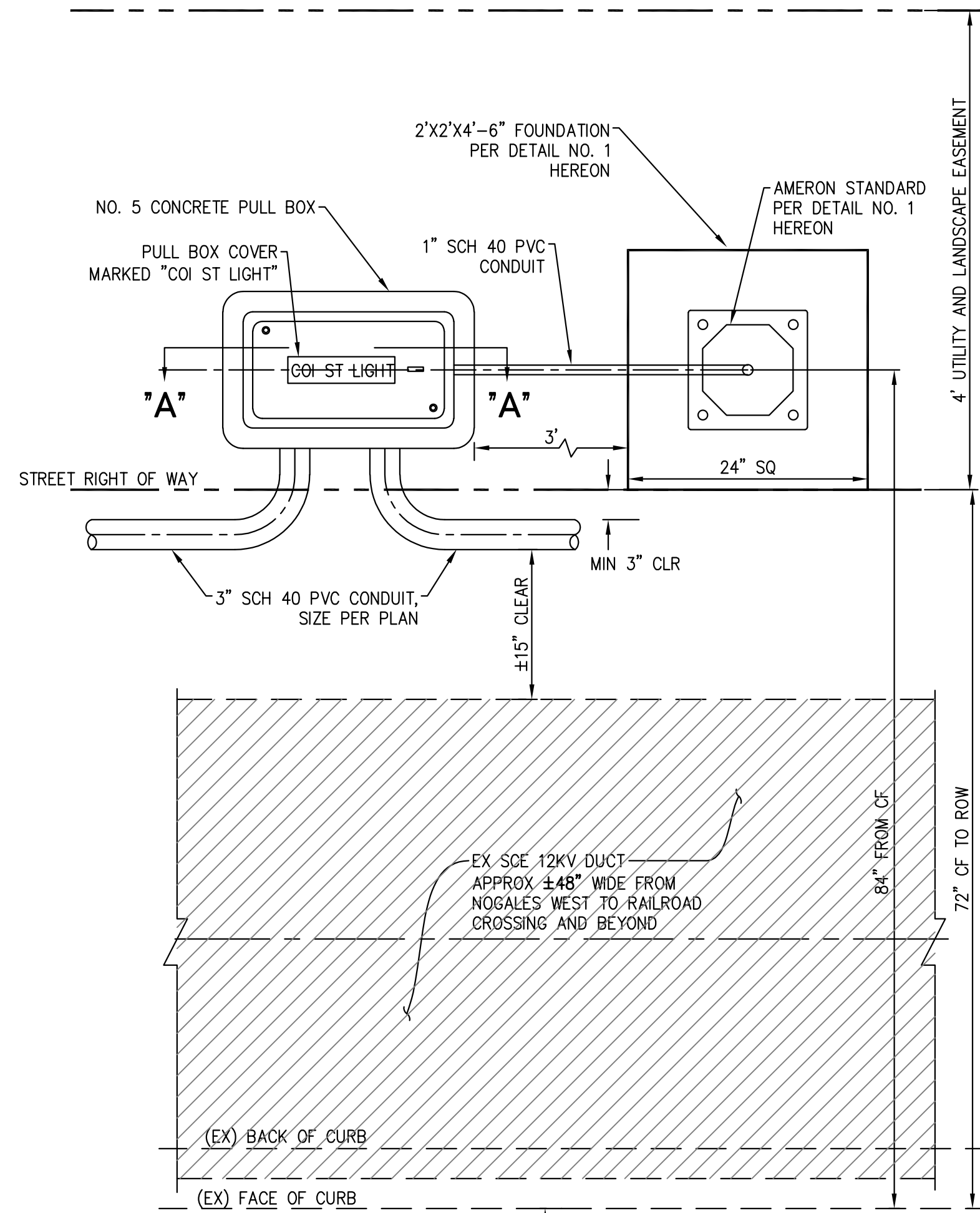

**NORTH SIDE SAN JOSE AVENUE  
FROM STA 2+20 TO STA 16+72**

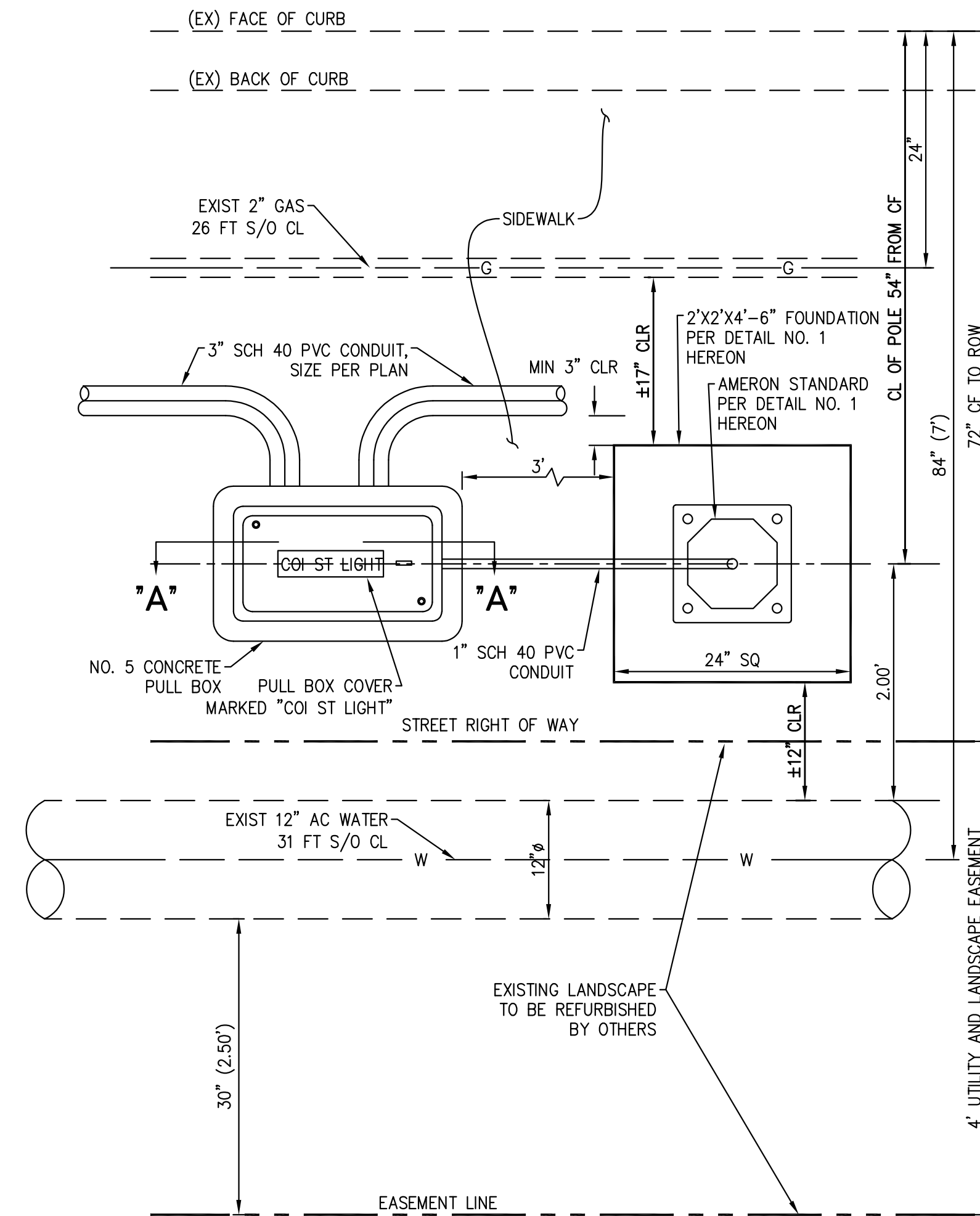

**SOUTH SIDE SAN JOSE AVENUE**

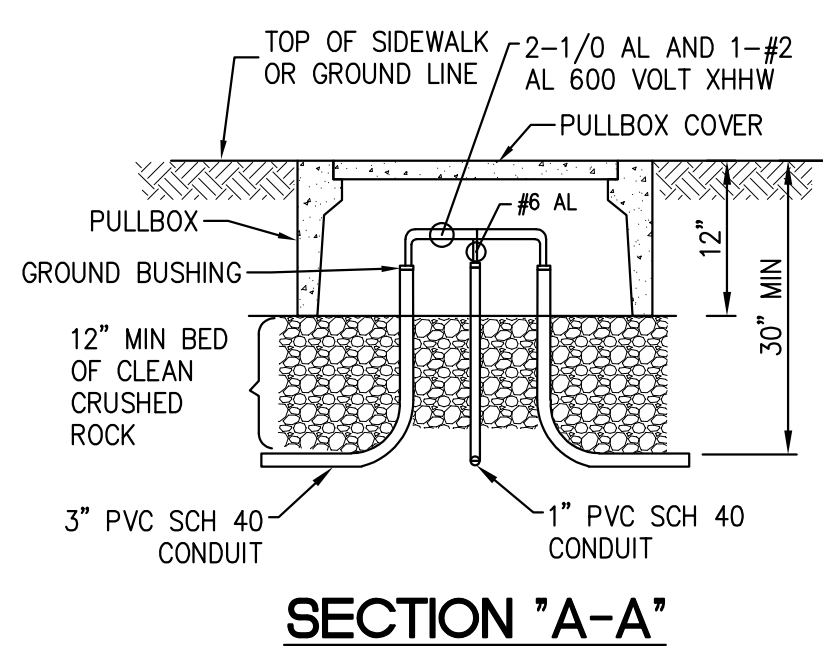

- NOTES:**
- PULL BOXES SHALL BE INSTALLED AT THE LOCATIONS SHOWN ON THE STREET LIGHT PLANS OR AS OTHERWISE SPECIFIED.
  - PULL BOXES SHALL BE PRECAST REINFORCED CONCRETE, NO. 5 PER CALTRANS STD PLAN RSP ES-8A OR APPROVED EQUAL.
  - WIRING SHALL NOT BE PULLED INTO CONDUIT UNTIL PULL BOXES ARE CAPPED.
  - REFER TO TYPICAL POLE MOUNTING DETAIL SHOWN HEREON.

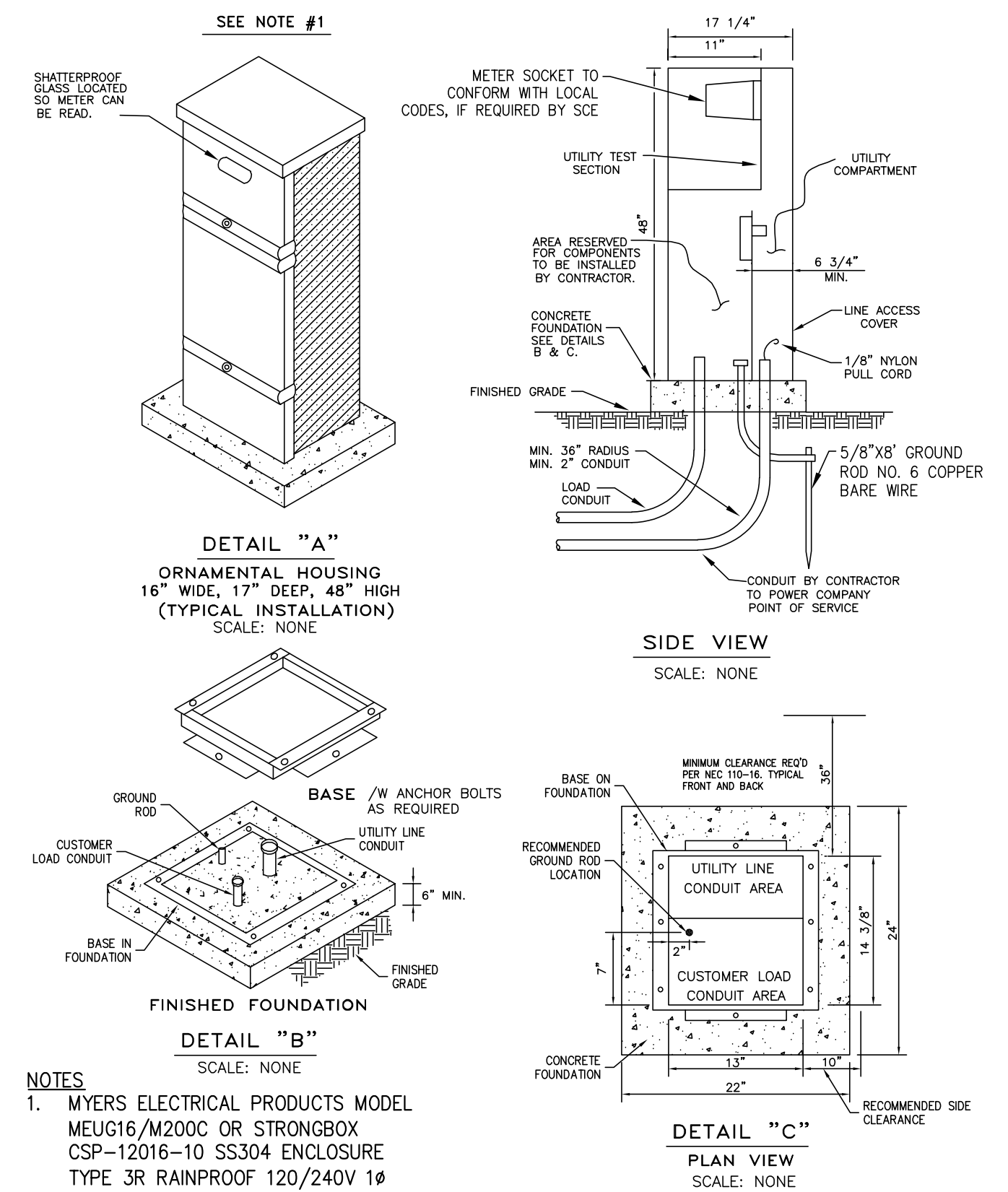

**3 TYPICAL SERVICE PEDESTAL DETAIL**  
SCALE: N.T.S.

**BENCHMARK**  
B.M. X-XX ELEV. X-XX  
XXXXXXXXXXXXXXXX  
XXXXXXXXXXXXXXXX  
XXXXXXXXXXXXXXXX

**Underground Service Alert**  
of Southern California  
Call: TOLL FREE  
**1-800-227-2600**  
or 811  
**TWO WORKING DAYS BEFORE YOU DIG**

NO.	DATE	REVISIONS	CHK. BY

**CITY OF INDUSTRY**  
INCORPORATED JUNE 18, 1957  
P.O. Box 3366, City of Industry, California 91744  
Administrative Offices: 15625 Mayor Dave Way (626) 333-2211

Prepared by:  
**ACNC ENGINEERING**  
255 N Hacienda Blvd | Ste 222  
City of Industry | CA | 91744  
P | 626.333.0336  
www.cnc-eng.com

**CITY OF INDUSTRY**

APPROVED BY: \_\_\_\_\_ DATE: \_\_\_\_\_  
CLEMENT N. CLEMENT, P.E., REG. PE, FEDERAL CITY ENGINEER DATE: DEPUTY CITY ENGINEER, PE, REG. 66959 CITY MANAGER DATE: \_\_\_\_\_

**SAN JOSE AVENUE RECONSTRUCTION  
FROM CHARLIE ROAD TO NOGALES STREET**

**DETAILS AND GENERAL NOTES**

DESIGNED BY: D.B. CHECKED BY: J.C. JOB NO. MP 08-09  
DRAFTED BY: E.C. DATE: FEB 2022 CONTRACT NO. CITY-1439 SHEET 3 OF 4

CONTRACT DRAWING OF \_\_\_\_\_

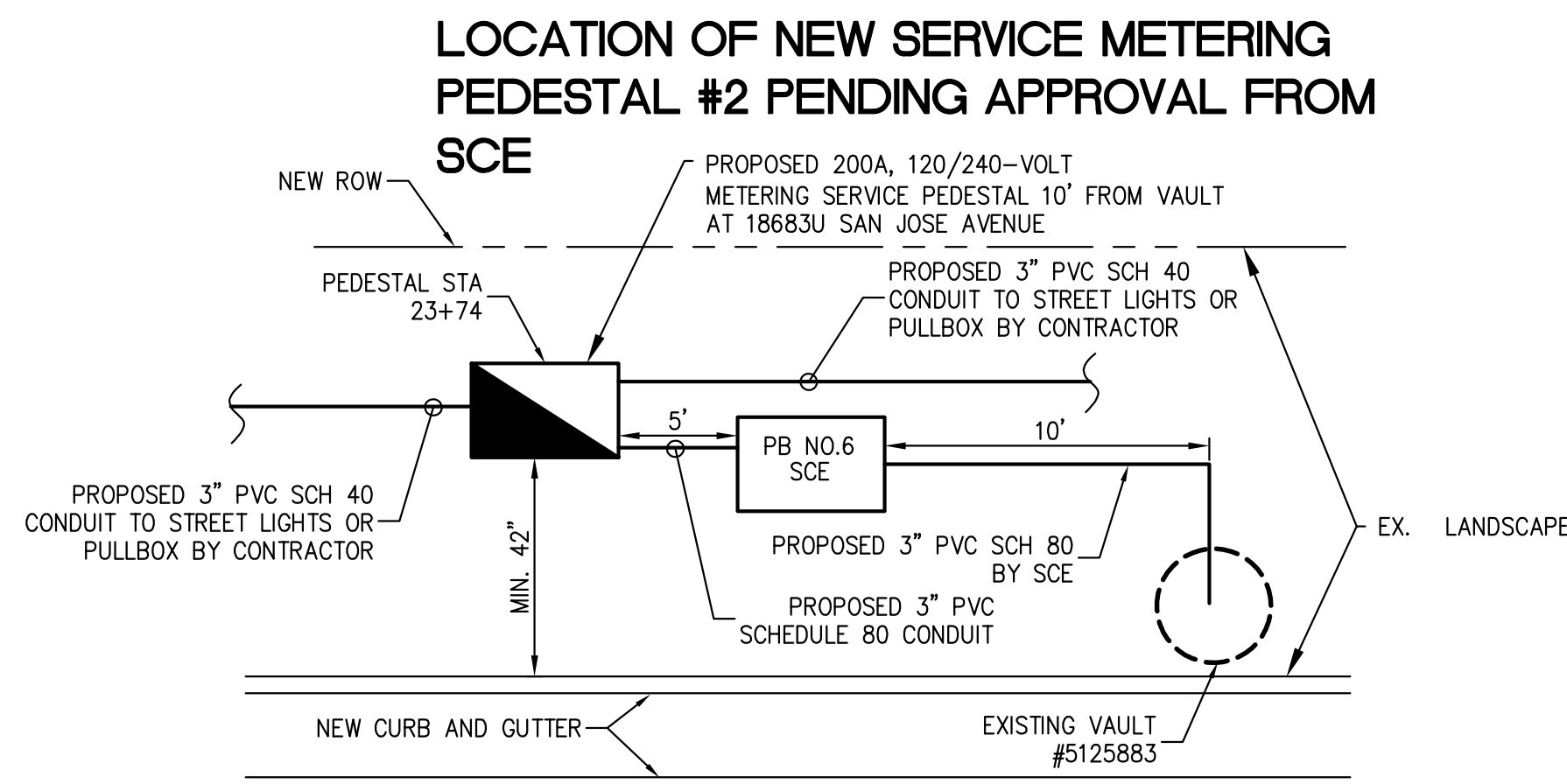

**4A** SERVICE FEED DETAIL BY SCE CONTRACTOR  
SCALE: N.T.S.

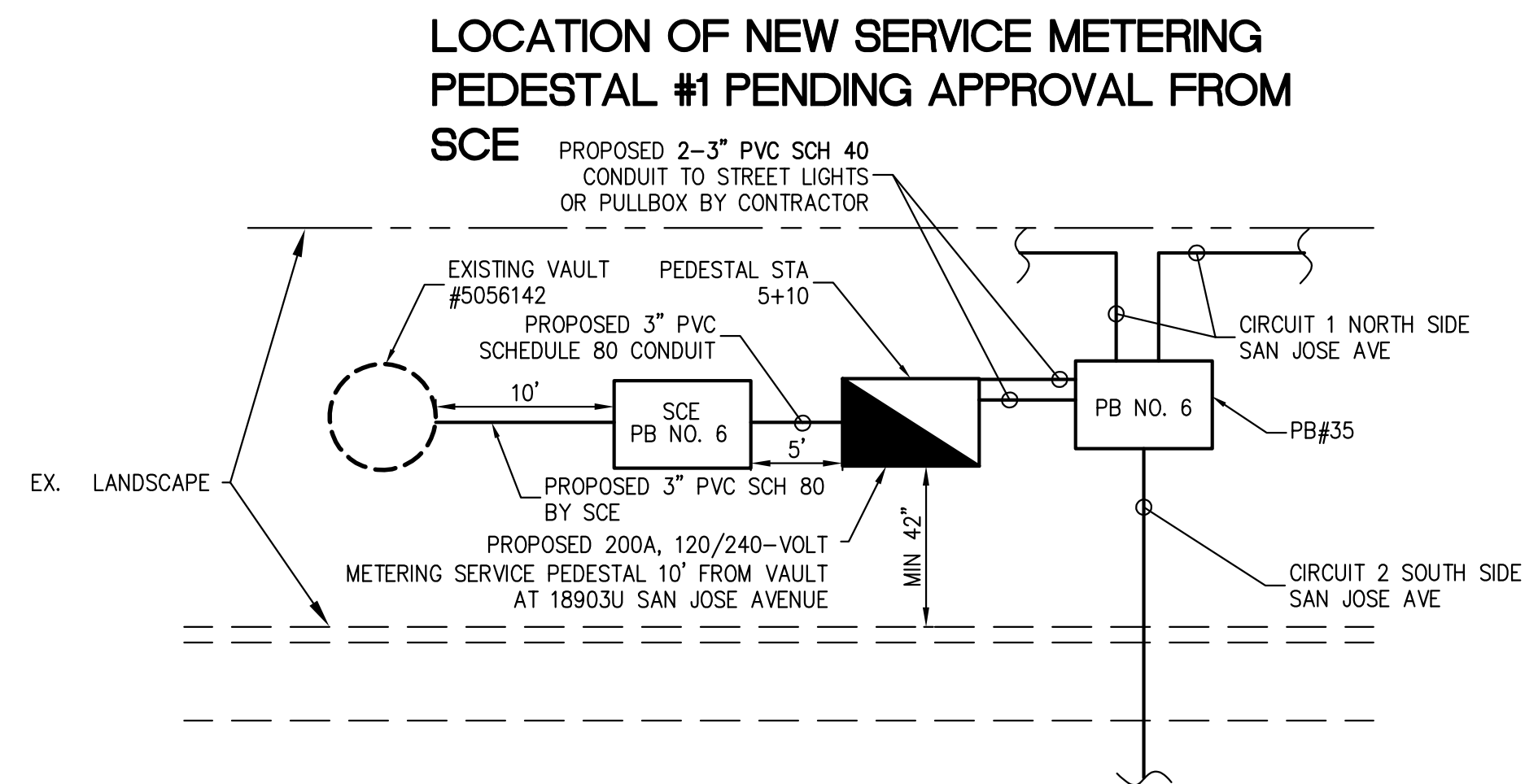

**4B** SERVICE FEED DETAIL BY SCE CONTRACTOR  
SCALE: N.T.S.

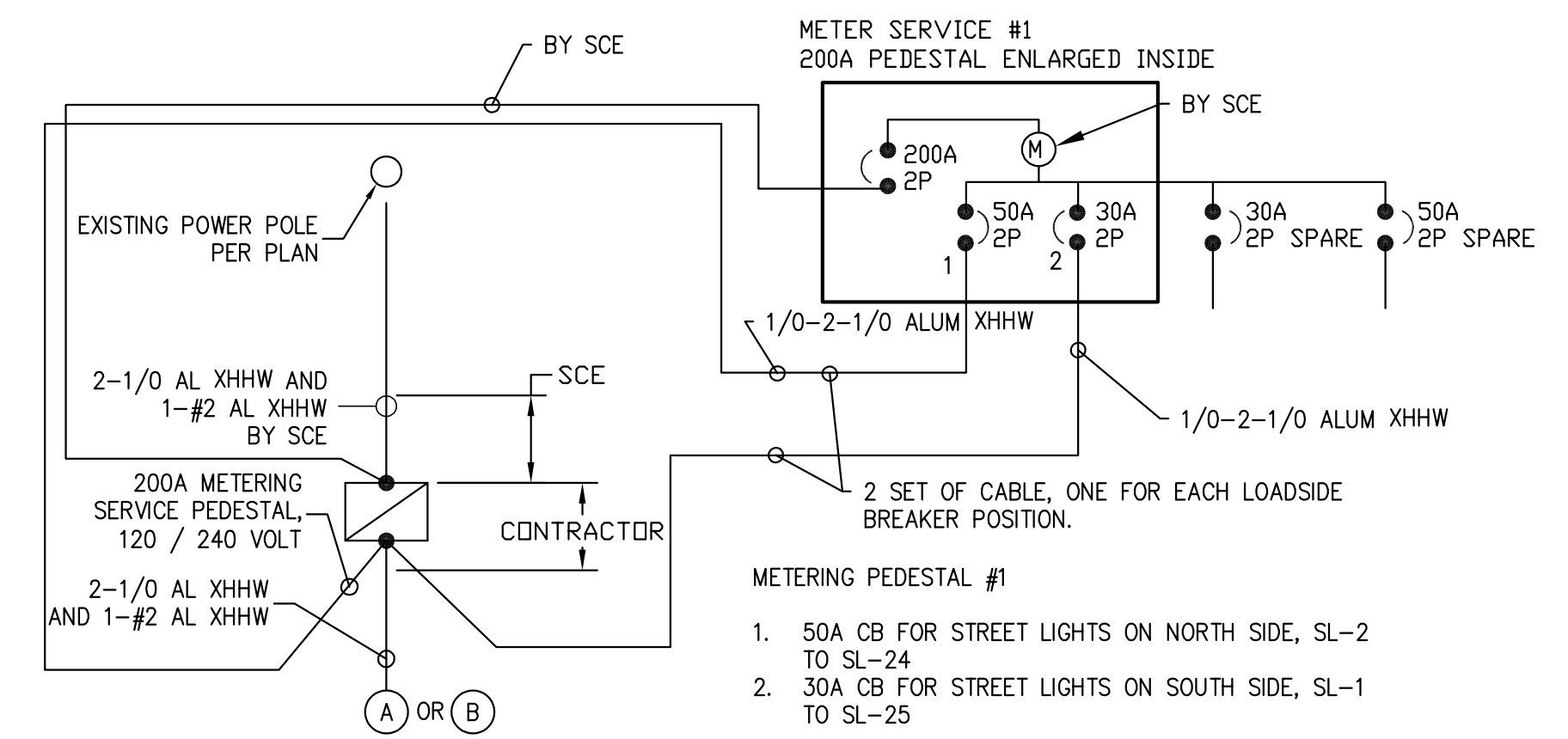

**4C** 200A SERVICE PEDESTAL DETAILS  
SCALE: N.T.S.

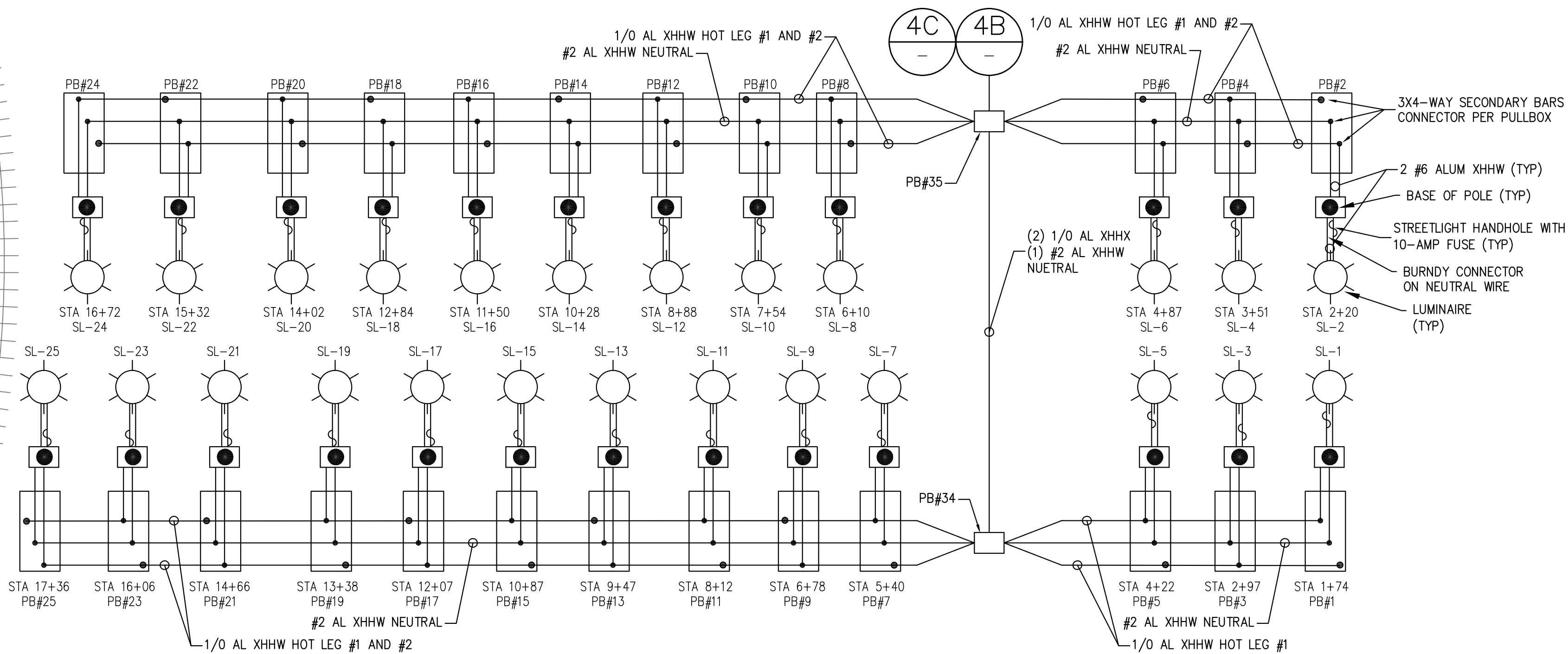
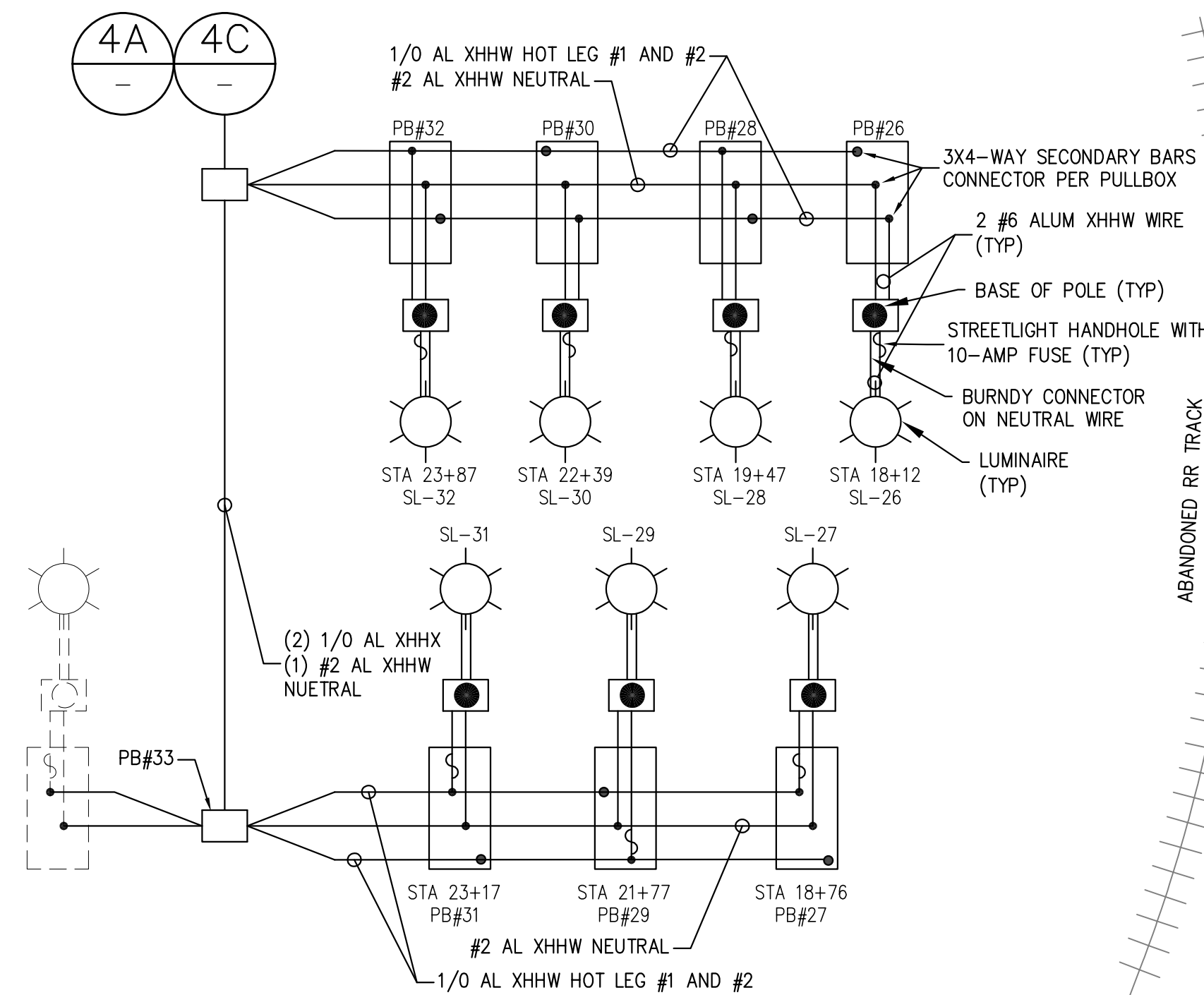

**5** WIRING DIAGRAM  
SCALE: N.T.S.

K:\Misc\0809 San Jose Ave Reconstruction - Railroad Street\Street Lighting Plan - San Jose ST LT 04 Wiring Diagram.dwg 2/28/2025 11:28 AM

**BENCHMARK**  
B.M. X-XX ELEV. X-XX  
XXXXXXXXXXXXXXXX  
XXXXXXXXXXXXXXXX  
XXXXXXXXXXXXXXXX

**Underground Service Alert**  
of Southern California  
Call: TOLL FREE  
**1-800-227-2600**  
or 811  
**TWO WORKING DAYS BEFORE YOU DIG**

NO.	DATE	REVISIONS	CK. BY



**CITY OF INDUSTRY**  
INCORPORATED JUNE 18, 1957  
P.O. Box 3366, City of Industry, California 91744  
Administrative Offices: 15625 Mayor Dave Way  
(626) 333-2211

Prepared by:  
**ACNC ENGINEERING**  
255 N Hacienda Blvd | Ste 222  
City of Industry | CA | 91744  
P | 626.333.0336  
www.cnc-eng.com  
REGISTRED PROFESSIONAL ENGINEER  
E 11608  
DEV D. BILRA, P.E. 11608

<b>CITY OF INDUSTRY</b>			
APPROVED BY:			
CLEMENT N. CLEMENT, P.E., REG. ELECTRICAL ENGINEER	DATE: DEPTUARY	CITY ENGINEER	DATE: CITY MANAGER
<b>SAN JOSE AVENUE RECONSTRUCTION FROM CHARLIE ROAD TO NOGALES STREET</b>			
<b>SCE SERVICE DETAIL AND WIRING DIAGRAM</b>			
DESIGNED BY: D.B.	CHECKED BY: J.C.	JOB NO. MP 08-09	SHEET 4 OF 4
DRAFTED BY: E.C.	DATE: FEB 2022	CONTRACT NO. CITY-1439	CONTRACT DRAWING OF

# CITY OF INDUSTRY IMPROVEMENT PROJECT

## SAN JOSE AVENUE RECONSTRUCTION FROM CHARLIE ROAD TO NOGALES STREET

### LANDSCAPE PLANS

#### CITY OF INDUSTRY, CA

COUNTY OF LOS ANGELES - DEPARTMENT OF HEALTH SERVICES  
PUBLIC HEALTH PROGRAMS AND SERVICES - ENVIRONMENTAL HEALTH  
CROSS-CONNECTION & WATER POLLUTION CONTROL PROGRAM  
5050 Commerce Drive, Rm. 115, Baldwin Park, CA 91706 (626) 430-5290

#### A GUIDE TO SAFE RECYCLED WASTEWATER USE, PIPELINE CONSTRUCTION AND INSTALLATION

INTRODUCTION: As a result of increasing availability of recycled wastewater and the consequent need or desire for the transmission and use thereof, this Department has found it necessary to develop the following guidelines for recycled wastewater pipeline construction, installation and safe recycled wastewater use for the protection of domestic water supplies and public health.

- Recycled wastewater shall meet requirements specified in "Wastewater Reclamation Criteria": Title 22, Division 4, Chapter 3, Section 60301 through 60355 of the California Code of Regulations and regulations and guidelines of the regulatory agencies.
- Recycled wastewater use shall be compatible with State Department of Health Services and Regional Water Quality Control Board requirements.
- Plans and specifications for recycled wastewater distribution, use and operational practices shall be submitted for review and approval to the County of Los Angeles Department of Health Services prior to implementation.
- Prior to commencing construction the Contractor shall contact the Los Angeles County Department of Health Services to arrange for inspection of all on-site recycled and potable water work. No excavation or open trench may be backfilled without first securing Health Department approval. If any piping, recycled or potable, is installed prior to plan check approval and/or inspection, all or any portion of the system may be required to be exposed and corrected as necessary.
- SEPARATION** - In order to minimize construction accidents resulting in pipeline breaks, infiltration of wastewater from leaking wastewater lines into domestic water lines, or accidental cross-connections between recycled wastewater and potable water systems, maximum attainable separation of recycled wastewater lines and potable water lines shall be practiced.
  - Parallel construction:** there shall be at least a ten foot (10') separation, all distances measured from pipeline outside diameter.
  - Cross-Over construction:** As perpendicular as possible; one foot (1') separation, with potable above recycled; full pipe length centered over crossing.
  - Alternate Cross-Over construction** (distance not maintained): Either the potable or recycled water lines may be sleeved with the same class piping for one full pipe length (minimum ten feet) centered over the cross-over.
  - The recycled wastewater system shall be constructed in conformance with potable water system construction standards and in accordance with all other governing codes, rules and regulations.
  - Unused or abandoned potable water lines are to be severed as close to water mains as practical, capped and a ten-foot section of abandoned line removed and cemented under Health Department supervision.
- Existing On-site piping** - To the extent feasible, maximum separation of recycled wastewater and potable water lines shall be practiced upon system addition or modification.
- IDENTIFICATION** - All recycled wastewater lines (pressure/non-pressure), valve boxes, hydrants and appurtenances shall be identified to clearly distinguish between recycled wastewater, non-potable and potable water systems.
  - RECYCLED WASTEWATER** - All buried recycled wastewater lines (pressure/non-pressure) shall be identified by the use of purple colored pipe with continuous wording "Caution Recycled Water" printed on opposite sides of the pipe. In areas where sleeving is required the use of continuous wording on three inch (3") minimum width purple tape with one inch black or white contrasting lettering bearing the continuous wording "Caution Recycled Water" permanently affixed at five foot intervals is acceptable. Identification tape shall extend to all valve boxes and/or vaults, exposed piping, hydrants and quick couplers.
  - POTABLE WATER** - All potable water lines shall be installed in accordance with the Uniform Plumbing Code and all other governing codes, rules and regulations. Buried potable water lines shall be identified by continuous wording on three inch (3") minimum width blue tape with one inch white lettering bearing the continuous wording "Potable Water" permanently affixed at ten foot intervals atop all horizontal piping, laterals and mains. Identification tape shall extend to all valve boxes and/or vaults, exposed piping and hydrants.  
Identification tape is not necessary for extruded colored PVC with continuous wording "Potable Water" printed in contrasting lettering on opposite sides of the pipe.
  - NON-POTABLE WATER** - All non-potable irrigation/industrial water lines (pressure/non-pressure) shall be identified by continuous wording on three inch (3") minimum width tape with one inch contrasting lettering

- "Caution Recycled Water Do Not Drink"** in black or white contrasting lettering on a purple background.
  - "Potable Water"** in white lettering on a blue background.
  - "Non-Potable Water - Do Not Drink"** in contrasting lettering from the background.
- Tags shall be identified with the appropriate wording on both sides. Tags identifying recycled water shall have the appropriate wording on one side and symbol on the opposite side.
- Aquifers shall be protected against contamination by recycled wastewater via deteriorated or inadequately protected waterwell casings by correcting these physical deficiencies. Recycled wastewater shall not be sprayed on well pump installations and appurtenances.
  - An **on-site water supervisor** having the responsibility for the protection of the potable water system from cross-connections, shall be appointed as provided for under Title 17, Section 7586, California Code of Regulations. The water supervisor shall be responsible for installation, operation, and maintenance of the recycled wastewater and potable water systems, prevention of potential hazards, implementing these guidelines and coordination with the cross-connection control program of the water purveyor and this Department. Authorizations for piping changes or additions to either the potable or recycled wastewater systems shall be subject to review and approval by the water purveyor. The name and position of this individual shall be reported to the water purveyor and the County of Los Angeles Department of Health Services.
  - As-built plans** shall be prepared and updated as necessary by the user showing the location of recycled wastewater and potable water system piping.
  - In areas of public access to recycled wastewater systems, **hose bibbs** shall not be permitted in order to prevent the unauthorized use of recycled wastewater. **Quick-couplers** are permissible in lieu of hose bibb outlets and shall only be connected to recycled wastewater lines.  
In areas not accessible to the public, hose bibbs may be permitted provided they are properly identified with permanently affixed tags, labels, or plates with the wording "Recycled Water - Do Not Drink" in English and symbol.
  - Exposure of drinking fountains and picnic tables to direct recycled wastewater spray shall be minimized by a combination of selective location of such equipment and by appropriate irrigation system design.
    - Recycled wastewater spraying shall be done in hours of least public exposure.
    - Areas where recycled wastewater is released, used or impounded shall be posted (e.g., RECYCLED WATER - DO NOT DRINK), to inform the public that recycled water is being used.
    - Irrigation practice shall be controlled to prevent surface runoff of recycled wastewater from lands owned or controlled by the user.
  - BACKFLOW PROTECTION**
    - There shall be no interconnection between the Potable Water System and the Recycled Water System within the user's premises.
    - A dye or pressure test must be utilized to confirm the physical separation of the recycled and potable water systems. Said testing shall be performed in conjunction with the Water Purveyor and this Department and conducted before the introduction of recycled wastewater.
    - Contact the local water purveyor regarding required backflow protection at the potable water service connection(s) to recycled water use sites.
    - In order to maintain the water quality in a recycled wastewater distribution system a backflow prevention device(s) may be required at the recycled wastewater meter or at specific on-site locations where said use could degrade the quality of the recycled wastewater supply.

policies\reclwast.wpd (05/27/05)

#### PROJECT LOCATION



#### VICINITY MAP

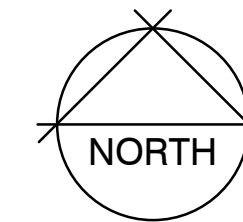

#### SHEET INDEX

COVER SHEET	SHEET 1
IRRIGATION PLAN	SHEET 2 - 3
IRRIGATION LEGEND & RECYCLED WATER NOTES	SHEET 4
PLANTING PLANS	SHEET 5-6
PLANTING LEGEND & NOTES	SHEET 7
EXISTING TREE PLANS	SHEET 8-9
HYDROZONE MAP/ WATER USE CALCULATIONS	SHEET 10
LANDSCAPE DETAILS	SHEET 11
SPECIFICATIONS	SHEET 12-14

### CITY OF INDUSTRY

APPROVED BY:

CLEMENT N. CALVILLO, PE, RCE 27743 DEPUTY CITY ENGINEER DATE JOSHUA L. NELSON, PE, RCE 66959 CITY MANAGER DATE

**SAN JOSE AVENUE RECONSTRUCTION  
FROM CHARLIE RD. TO NOGALES STREET**

### COVER SHEET

DESIGNED BY:	CHECKED BY: —	JOB NO. CITY - MP 08-09	SHT. 1 OF 14
DRAFTED BY:	DATE: APRIL 12, 2022		

CONTRACT DRAWING OF



Know what's below.  
Call before you dig.

NO.	DATE	REVISIONS	CK.	BY



### CITY OF INDUSTRY

INCORPORATED JUNE 18, 1957  
P.O. Box 3366, City of Industry, California 91744  
Administrative Offices: 15625 Mayor Dave Way  
(626) 333-2211



Prepared by: **Environs Inc.**  
LANDSCAPE ARCHITECTURE  
Creating Sustainable & Water Conserving Solutions  
801 El Berrero • San Clemente, CA 92672  
PH: (949) 626-4663

BRETT FRENCH, RLA #3416 DATE 4-12-22  
DESIGN BY: BKF DRAWN BY: BKF

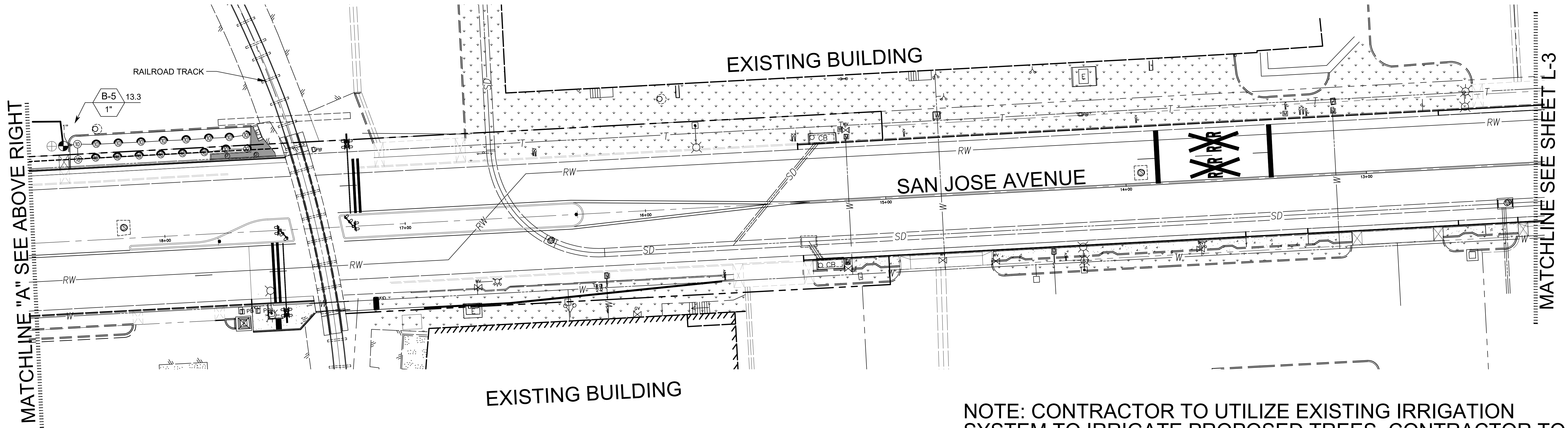
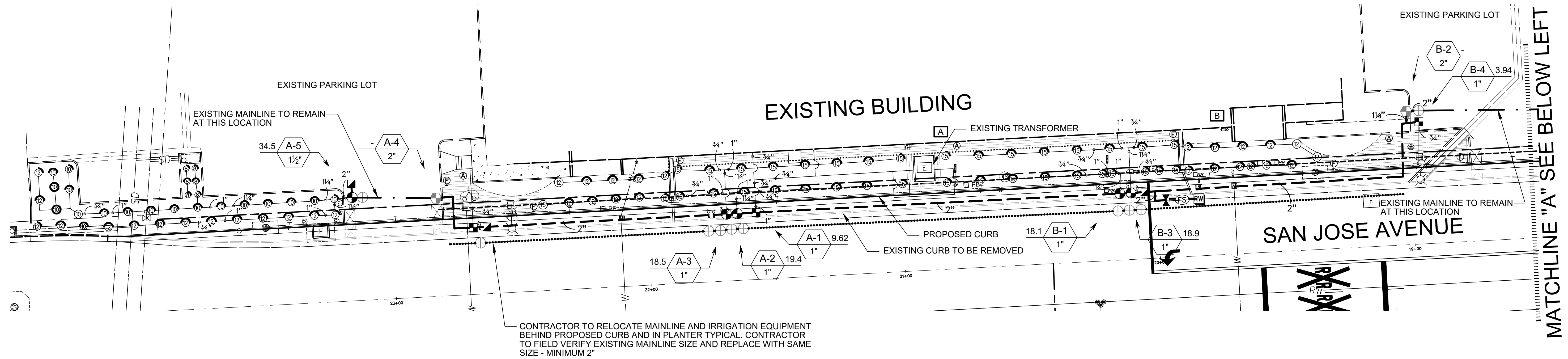

NOTE: FOR IRRIGATION LEGEND SEE SHEET 4

NOTE: CONTRACTOR TO UTILIZE EXISTING IRRIGATION SYSTEM TO IRRIGATE PROPOSED TREES. CONTRACTOR TO REPAIR EXISTING SYSTEM WHERE NECESSARY IN ORDER TO IRRIGATE TREES.

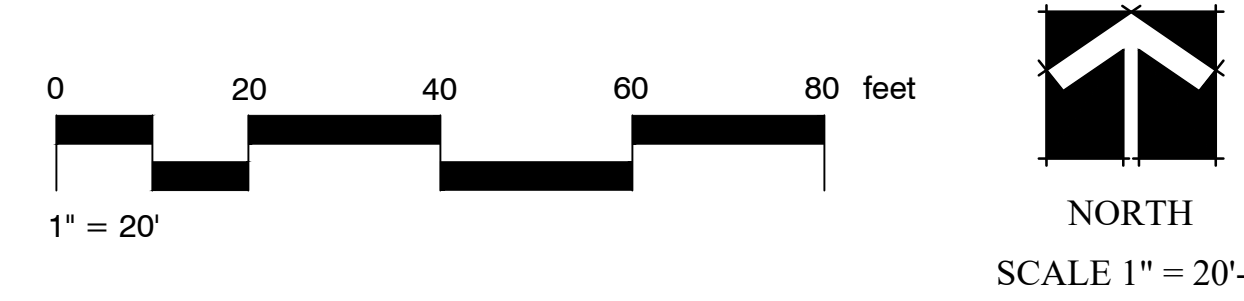

CITY OF INDUSTRY			
APPROVED BY: _____ DATE: _____			
CLEMENT N. CALVILLO, PE, RCE 27743		DEPUTY CITY ENGINEER	
SAN JOSE AVENUE RECONSTRUCTION FROM CHARLIE RD. TO NOGALES STREET			
IRRIGATION PLAN			
DESIGNED BY: _____	CHECKED BY: _____	JOB NO. CITY - MP 08-09	SHT. 2 OF 14
DRAFTED BY: _____	DATE: APRIL 12, 2022	CONTRACT DRAWING OF	



NO.	DATE	REVISIONS	CK. BY

**CITY OF INDUSTRY**

INCORPORATED JUNE 18, 1957  
 P.O. Box 3366, City of Industry, California 91744  
 Administrative Offices: 15625 Mayor Dave Way  
 (626) 333-2211

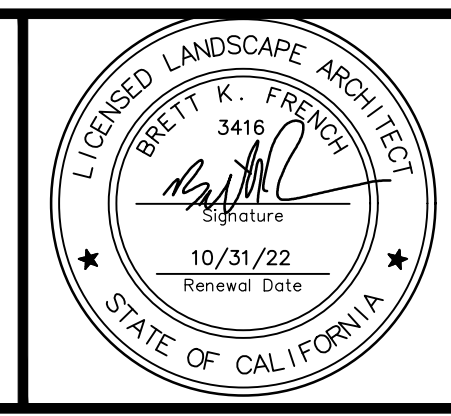

Prepared by: **Environs** INC  
 LANDSCAPE ARCHITECTURE  
 Creating Sustainable & Water Conserving Solutions  
 801 El Berrero • San Clemente, CA 92672  
 PH: (949) 626-4663

DESIGN BY: BRETT FRENCH, RLA #3416 DATE: 4-12-22  
 DRAWN BY: BKF

MATCHLINE SEE SHEET L-2

MATCHLINE SEE "A" THIS SHEET

MATCHLINE SEE "A" THIS SHEET

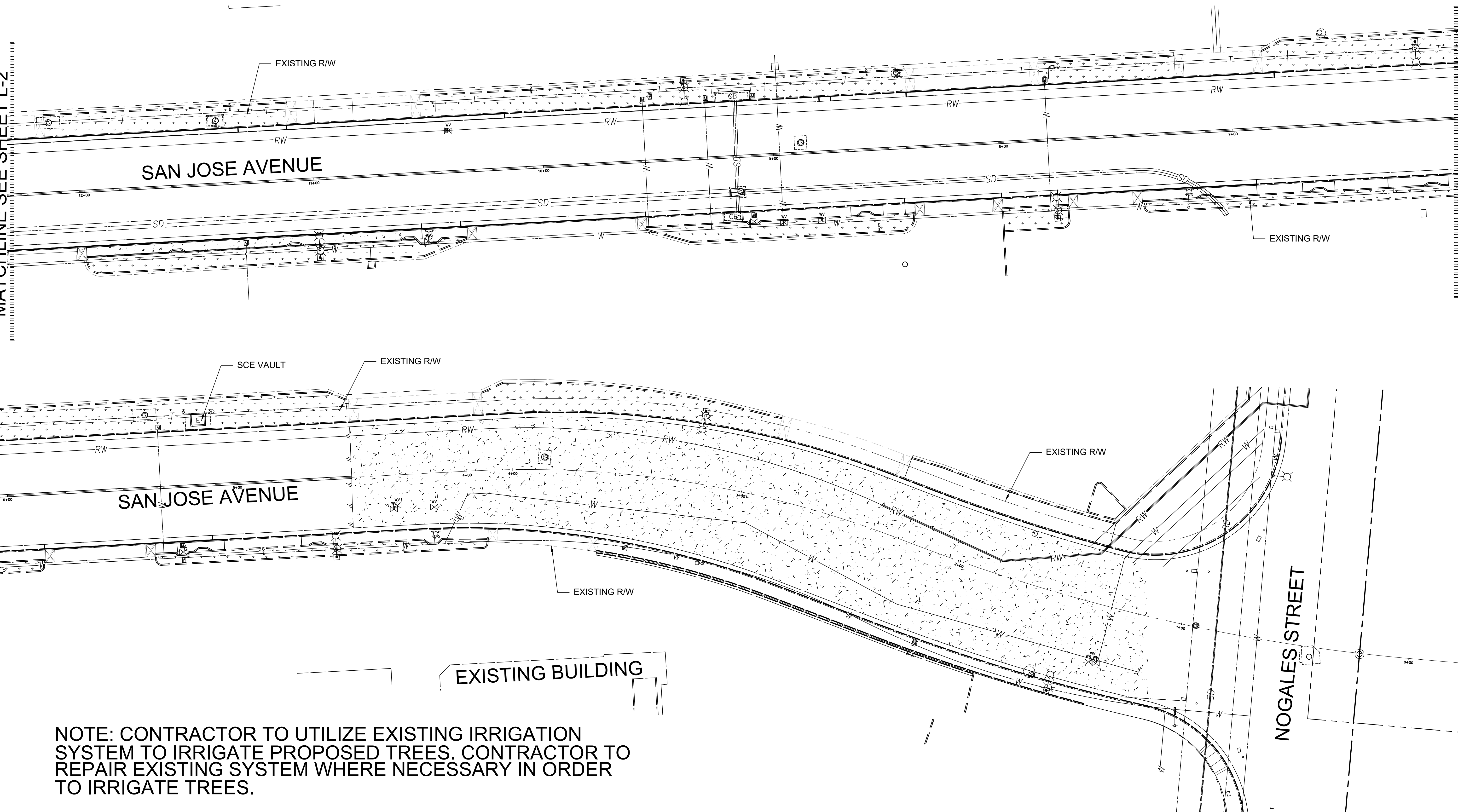

NOTE: CONTRACTOR TO UTILIZE EXISTING IRRIGATION SYSTEM TO IRRIGATE PROPOSED TREES. CONTRACTOR TO REPAIR EXISTING SYSTEM WHERE NECESSARY IN ORDER TO IRRIGATE TREES.

NOTE: FOR IRRIGATION LEGEND SEE SHEET 4

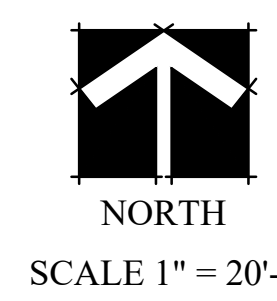
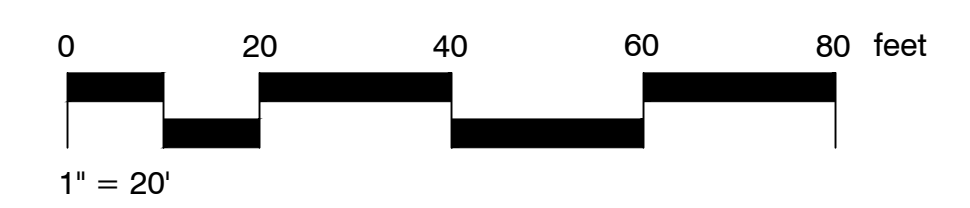

SCALE 1" = 20'-0"

CITY OF INDUSTRY

APPROVED BY: \_\_\_\_\_  
CLEMENT N. CALVILLO, PE, RCE 27743 DEPUTY CITY ENGINEER

SAN JOSE AVENUE RECONSTRUCTION  
 FROM CHARLIE RD. TO NOGALES STREET

IRRIGATION PLAN

DESIGNED BY: \_\_\_\_\_ CHECKED BY: \_\_\_\_\_  
DATE: APRIL 12, 2022

JOB NO. CITY - MP 08-09 SHT. 3 OF 14

CONTRACT DRAWING OF



NO.	DATE	REVISIONS	CK. BY



CITY OF INDUSTRY

INCORPORATED JUNE 18, 1957  
 P.O. Box 3366, City of Industry, California 91744  
 Administrative Offices: 15625 Mayor Dave Way  
 (626) 333-2211

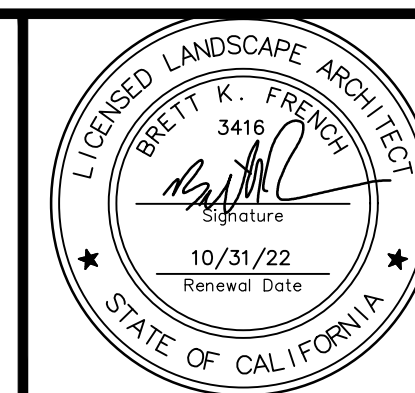

Prepared by: **Environs** Inc  
 LANDSCAPE ARCHITECTURE  
 Creating Sustainable & Water Conserving Solutions  
 801 El Berrero • San Clemente, CA 92672  
 PH. (949) 626-4663

BRETT FRENCH, RLA #3416 DATE: 4-12-22  
 DESIGN BY: BKF DRAWN BY: BKF

A GUIDE TO SAFE RECYCLED WASTEWATER USE, PIPELINE CONSTRUCTION AND INSTALLATION

INTRODUCTION: As a result of increasing availability of recycled wastewater and the consequent need or desire for the transmission and use thereof, this Department has found it necessary to develop the following guidelines for recycled wastewater pipeline construction, installation and safe recycled wastewater use for the protection of domestic water supplies and public health.

- Recycled wastewater shall meet requirements specified in "Wastewater Reclamation Criteria", Title 22, Division 4, Chapter 3, Section 60301 through 60355 of the California Code of Regulations and regulations and guidelines of the regulatory agencies.
- Recycled wastewater use shall be compatible with State Department of Health Services and Regional Water Quality Control Board requirements.
- Plans and specifications for recycled wastewater distribution, use and operational practices shall be submitted for review and approval to the County of Los Angeles Department of Health Services prior to implementation.
- Prior to commencing construction the Contractor shall contact the Los Angeles County Department of Health Services to arrange for inspection of all on-site recycled and potable water work. No excavation or open trench may be backfilled without first securing Health Department approval. If any piping, recycled or potable, is installed prior to plan check approval and/or inspection, all or any portion of the system may be required to be exposed and corrected as necessary.
- SEPARATION** - In order to minimize construction accidents resulting in pipeline breaks, infiltration of wastewater from leaking wastewater lines into domestic water lines, or accidental cross-connections between recycled wastewater and potable water systems, maximum attainable separation of recycled wastewater lines and potable water lines shall be practiced.
  - Parallel construction:** there shall be at least a ten foot (10') separation, all distances measured from pipeline outside diameter.
  - Cross-Over construction:** As perpendicular as possible; one foot (1') separation, with potable above recycled; full pipe length centered over crossing.
  - Alternate Cross-Over construction** (distance not maintained): Either the potable or recycled water lines may be sleeved with the same class piping for one full pipe length (minimum ten feet) centered over the cross-over.

**Existing On-site piping** - To the extent feasible, maximum separation of recycled wastewater and potable water lines shall be practiced upon system addition or modification.

- IDENTIFICATION** - All recycled wastewater lines (pressure/non-pressure), valve boxes, hydrants and appurtenances shall be identified to clearly distinguish between recycled wastewater, non-potable and potable water systems.
  - RECYCLED WASTEWATER** - All buried recycled wastewater lines (pressure/non-pressure) shall be identified by the use of purple colored pipe with continuous wording "Caution Recycled Water" printed on opposite sides of the pipe. In areas where sleeving is required the use of continuous lettering on three inch (3") minimum width purple tape with one inch black or white contrasting lettering bearing the continuous wording "Caution Recycled Water" permanently affixed at five foot intervals is acceptable. Identification tape shall extend to all valve boxes and/or vaults, exposed piping, hydrants and quick couplers.
  - POTABLE WATER** - All potable water lines shall be installed in accordance with the Uniform Plumbing Code and all other governing codes, rules and regulations. Buried potable water lines shall be identified by continuous lettering on three inch (3") minimum width blue tape with one inch white lettering bearing the continuous wording "Potable Water" permanently affixed at ten foot intervals atop all horizontal piping, laterals and mains. Identification tape shall extend to all valve boxes and/or vaults, exposed piping and hydrants.

Identification tape is not necessary for extruded colored PVC with continuous wording "Potable Water" printed in contrasting lettering on opposite sides of the pipe.

- NON-POTABLE WATER** - All non-potable irrigation/industrial water lines (pressure/non-pressure) shall be identified by continuous lettering on three inch (3") minimum width tape with one inch contrasting lettering

IRRIGATION NOTES

- IT IS THE INTENT OF THESE DRAWINGS TO INDICATE A COMPLETE AND OPERATIONAL IRRIGATION SYSTEM GIVING FULL COVERAGE AND READY FOR USE BY THE OWNER. THE DRAWINGS ARE BASED ON LANDSCAPE AND GRADING DRAWINGS IN EFFECT AT THE TIME THESE DRAWINGS WERE MADE. ANY DISCREPANCIES, OMISSIONS, ERRORS, ETC. ON THESE DRAWINGS OR ON SITE CHANGES, DO NOT AND SHALL NOT RELIEVE THE CONTRACTOR OF HIS RESPONSIBILITY TO PROVIDE A COMPLETE SYSTEM AS SHOWN. IF NECESSARY, THE CONTRACTOR MAY, WHERE CHANGES OCCUR, ADD OR DELETE SPRINKLERS, REROUTE PIPE, ETC. TO ASSURE ADEQUATE AND FULL COVERAGE.
- IRRIGATION CONTRACTOR SHALL VERIFY ALL PRESSURES ON SITE PRIOR TO CONSTRUCTION.
- CONTRACTOR SHALL INSTALL CHECK VALVES IN ALL HEADS IN WHICH LOW HEAD DRAINAGE OCCURS.
- LOCATE ALL VALVES IN PLANTING AREAS.
- IRRIGATION SYSTEM IS STRICTLY DIAGRAMMATIC, THEREFORE, CONTRACTOR MUST MAKE ADJUSTMENTS IN THE FIELD TO INSURE ADEQUATE COVERAGE.
- IRRIGATION SYSTEM SHALL CONFORM TO STATE AND LOCAL CODES.
- ALL SHRUBBERY-TYPE HEADS ADJACENT TO WALKS SHALL BE INSTALLED AS LOW AS NECESSARY TO PREVENT ANY DAMAGE TO IRRIGATION SYSTEM.
- THE SYSTEM SHALL BE FULLY GUARANTEED FOR A PERIOD OF ONE YEAR. ANY DEFECTIVE MATERIAL OR POOR WORKMANSHIP SHALL BE REPLACED OR CORRECTED BY THE IRRIGATION CONTRACTOR AT NO COST TO THE OWNER.
- 120 VOLT ELECTRICAL POWER OUTLET FOR CONTROLLERS SHALL BE PROVIDED AS NOTED. IRRIGATION CONTRACTOR SHALL BE RESPONSIBLE FOR MAKING HOOK-UP FROM OUTLET TO CONTROLLER.
- ALL WIRE FROM CONTROLLER TO ELECTRIC CONTROL VALVES SHALL BE COPPER UF #14 DIRECT BURIAL. USE BLACK FOR PILOT, WHITE FOR COMMON. INSTALL IN COMMON TRENCH WITH MAIN LINE PIPING WHERE POSSIBLE.
- PROVIDE MINIMUM 18" COVER OVER ALL PRESSURE MAIN LINE PIPING, AND 12" OVER ALL NON-PRESSURE LATERAL LINE PIPING. ALL PIPE UNDER PAVED AREAS IS TO BE INSTALLED IN A PVC SCH. 40 SLEEVE WITH 36" MIN. COVER. SLEEVE LOCATIONS TO BE AS SHOWN ON PLANS. CITY DEPTH REQUIREMENTS FOR PIPE SUPERCEDE ALL THE ABOVE DIMENSIONS.
- IRRIGATION CONTRACTOR SHALL FLUSH ALL LINES AND ADJUST ALL HEADS FOR MAXIMUM PERFORMANCE AND TO PREVENT OVERSPRAY AS MUCH AS POSSIBLE.
- DO NOT FULLY INSTALL THE SYSTEM AS DESIGNED WHEN IT IS OBVIOUS IN THE FIELD THAT UNKNOWN OBSTRUCTIONS OR GRADE DIFFERENCES EXIST THAT WERE NOT KNOWN DURING THE DESIGN PROCESS. SUCH CONDITIONS SHALL BE BROUGHT TO THE ATTENTION OF THE OWNER'S AUTHORIZED REPRESENTATIVE, OTHERWISE, THE IRRIGATION CONTRACTOR MUST ASSUME FULL RESPONSIBILITY FOR ANY AND ALL NECESSARY REVISIONS.
- FINAL LOCATION OF AUTOMATIC CONTROLLER AND THE BACKFLOW PREVENTER SHALL BE DETERMINED BY OWNER'S AUTHORIZED REPRESENTATIVE AND/OR LANDSCAPE ARCHITECT.
- FLUSH AND ADJUST ALL SPRINKLER HEADS FOR OPTIMUM PERFORMANCE AND TO PREVENT OVERSPRAY ONTO WALKS AND WALLS/FENCES AS MUCH AS POSSIBLE.
- RAINBIRD DRIP LINE SHALL BE INSTALLED 4" BELOW GRADE (NOT INCLUDING MULCH COVER)
- LOCATION OF P.O.C. IS ONLY DIAGRAMMATIC. LOCATION MUST BE VERIFIED IN FIELD.
- IN ADDITION TO THE SLEEVES SHOWN ON THE PLAN, THE IRRIGATION CONTRACTOR SHALL BE RESPONSIBLE FOR THE INSTALLATION OF ADDITIONAL SLEEVES OF SUFFICIENT SIZE UNDER ALL PAVED AREAS PRIOR TO PAVING UPON APPROVAL OF THE OWNER'S REPRESENTATIVE, IF REQUIRED TO OPERATE SYSTEMS.
- MAINLINE FEEDER BETWEEN POINT OF CONNECTION, METER AND BACKFLOW PREVENTER TO BE OF MATERIAL AS REQUIRED BY CURRENT WATER DISTRICT.

bearing the continuous wording "Non-Potable Water" permanently affixed at ten foot intervals atop all horizontal piping, laterals and mains. Identification tape shall extend to all valve boxes and/or vaults, exposed piping, hydrants and quick couplers. Non-potable water is water supplied from the potable water system through an appropriate backflow preventer.

- Exposed piping, valve boxes, vaults, control valves, quick coupling valves, outlets and related appurtenances shall be color coded and labeled or tagged to differentiate between recycled wastewater, potable water and non-potable water systems, i.e.,
  - "Caution Recycled Water Do Not Drink" in black or white contrasting lettering on a purple background.
  - "Potable Water" in white lettering on a blue background.
  - "Non-Potable Water - Do Not Drink" in contrasting lettering from the background.

Tags shall be identified with the appropriate wording on both sides. Tags identifying recycled water shall have the appropriate wording on one side and symbol on the opposite side.

- Aquifers shall be protected against contamination by recycled wastewater via deteriorated or inadequately protected waterwell casings by correcting these physical deficiencies. Recycled wastewater shall not be sprayed on well pump installations and appurtenances.
- An on-site water supervisor having the responsibility for the protection of the potable water system from cross-connections, shall be appointed as provided for under Title 17, Section 7586, California Code of Regulations. The water supervisor shall be responsible for installation, operation, and maintenance of the recycled wastewater and potable water systems, prevention of potential hazards, implementing these guidelines and coordination with the cross-connection control program of the water purveyor and this Department. Authorizations for piping changes or additions to either the potable or recycled wastewater systems shall be subject to review and approval by the water purveyor. The name and position of this individual shall be reported to the water purveyor and the County of Los Angeles Department of Health Services.
- As-built plans shall be prepared and updated as necessary by the user showing the location of recycled wastewater and potable water system piping.
- In areas of public access to recycled wastewater systems, hose bibbs shall not be permitted in order to prevent the unauthorized use of recycled wastewater. Quick-couplers are permissible in lieu of hose bibb outlets and shall only be connected to recycled wastewater lines.

In areas not accessible to the public, hose bibbs may be permitted provided they are properly identified with permanently affixed tags, labels, or plates with the wording "Recycled Water - Do Not Drink" in English and symbol.

- Recycled wastewater spraying shall be done in hours of least public exposure.
- Areas where recycled wastewater is released, used or impounded shall be posted (e.g., RECYCLED WATER - DO NOT DRINK), to inform the public that recycled water is being used.
- Irrigation practice shall be controlled to prevent surface runoff of recycled wastewater from lands owned or controlled by the user.

- BACKFLOW PROTECTION**
  - There shall be no interconnection between the Potable Water System and the Recycled Water System within the user's premises.
  - A dye or pressure test must be utilized to confirm the physical separation of the recycled and potable water systems. Said testing shall be performed in conjunction with the Water Purveyor and this Department and conducted before the introduction of recycled wastewater.
  - Contact the local water purveyor regarding required backflow protection at the potable water service connection(s) to recycled water use sites.
  - In order to maintain the water quality in a recycled wastewater distribution system a backflow prevention device(s) may be required at the recycled wastewater meter or at specific on-site locations where said use could degrade the quality of the recycled wastewater supply.

:\policies\veclwast.wpd (05/27/05)

IRRIGATION SCHEDULE

SYMBOL	DESCRIPTION	PRECIP	PSI	GPM
	EXISTING IRRIGATION TO REMAIN - PROTECT IN PLACE	1.85 in/h	30	493

SYMBOL	MANUFACTURER/MODEL/DESCRIPTION	PSI
	Rain Bird RD-12-S-P30-F-N-U8 Series 12.0" Pop-Up, with 30 psi in-stem pressure regulation, Seal-A-Matic check valve, Flow-Shield Technology, and Non-Potable Cover (purple cap). 1/2" NPT female threaded inlet.	30

SYMBOL	MANUFACTURER/MODEL/DESCRIPTION	PSI
	Rain Bird RD-12-S-P30-F-N-U10 Series 12.0" Pop-Up, with 30 psi in-stem pressure regulation, Seal-A-Matic check valve, Flow-Shield Technology, and Non-Potable Cover (purple cap). 1/2" NPT female threaded inlet.	30

SYMBOL	MANUFACTURER/MODEL/DESCRIPTION	PSI
	Rain Bird RD-12-S-P30-F-N-U12 Series 12.0" Pop-Up, with 30 psi in-stem pressure regulation, Seal-A-Matic check valve, Flow-Shield Technology, and Non-Potable Cover (purple cap). 1/2" NPT female threaded inlet.	30

SYMBOL	MANUFACTURER/MODEL/DESCRIPTION	PSI
	Rain Bird RD-12-S-P30-F-N-U15 Series 12.0" Pop-Up, with 30 psi in-stem pressure regulation, Seal-A-Matic check valve, Flow-Shield Technology, and Non-Potable Cover (purple cap). 1/2" NPT female threaded inlet.	30

SYMBOL	MANUFACTURER/MODEL/DESCRIPTION	PSI
	Rain Bird RD-12-S-P30-F-N-U ADJ 12.0" Pop-Up, with 30 psi in-stem pressure regulation, Seal-A-Matic check valve, Flow-Shield Technology, and Non-Potable Cover (purple cap). 1/2" NPT female threaded inlet.	30

SYMBOL	MANUFACTURER/MODEL/DESCRIPTION
	Rain Bird XCZ-100-PRB-COM Drip Control Kit, 1" PESB valve, 1" Basket Filter, and 40psi Pressure Regulator, 1" Ball Valve located in a Recycled Water Purple Valve Box.

SYMBOL	MANUFACTURER/MODEL/DESCRIPTION
	Toro T-FCH-H-FIPT Flush Valve, plumbed to flush manifold at low point. Install in round purple (Recycled Water) valve box.

SYMBOL	MANUFACTURER/MODEL/DESCRIPTION
	Rain Bird ARV075 3/4" Air Relief Valve, made of quality rust-proof materials, with a 6.0" drip valve box (SEB 7XB emitter box). Use with installation below soil. The valve will allow air to escape the pipeline, thus preventing water hammer or blockage. Install in round purple (Recycled Water) valve box.

SYMBOL	MANUFACTURER/MODEL/DESCRIPTION
	Circular Dripline for Medium Water Trees Rainbird XFSP-09-12 (12) in a double circular pattern around trees. See typical dripline details.

SYMBOL	MANUFACTURER/MODEL/DESCRIPTION
	Area to Receive Dripline Rain Bird XFSP-09-18 (18) Recycled Water Purple Landscape Dripline with Copper Shield, 0.92gph emitters at 18" o.c. Dripline laterals spaced at 18" apart, with emitters offset for triangular pattern. See Details on Sheet L-13

SYMBOL	MANUFACTURER/MODEL/DESCRIPTION
	Existing Control Valve Existing Remote Control Valve to be replaced and relocated to new location shown on plan

SYMBOL	MANUFACTURER/MODEL/DESCRIPTION
	Existing Remote control valve to remain Contractor to protect in place.

SYMBOL	MANUFACTURER/MODEL/DESCRIPTION
	Rain Bird PEB Electric Remote Control Valve in Recycled Water Purple Valve Box. - Contractor to replace existing valves and connect into existing control wires and controller. Contractor to field verify existing valves since As-Built Irrigation Plans are unavailable.

SYMBOL	MANUFACTURER/MODEL/DESCRIPTION
	Rain Bird 33-DNP 3/4" Non-potable Quick Coupler Valve, two piece body located in a purple recycled water round valve box.

SYMBOL	MANUFACTURER/MODEL/DESCRIPTION
	Nibco T-113 Class 125 bronze gate shut off valve with wheel handle, same size as mainline pipe diameter at valve location. Located in purple recycled water round valve box

SYMBOL	MANUFACTURER/MODEL/DESCRIPTION
	Existing Irrigation Controller to Remain

SYMBOL	MANUFACTURER/MODEL/DESCRIPTION
	Existing Irrigation Controller to Remain

SYMBOL	MANUFACTURER/MODEL/DESCRIPTION
	Hayward Basket Strainer - Line Size Hayward Basket Strainer #72 Cast Iron with 200 Mesh Located in a Rectangular Recycled Water (Purple) Valve Box

SYMBOL	MANUFACTURER/MODEL/DESCRIPTION
	Water Meter 1-1/2" - EXISTING RECYCLED WATER METER FOR LANDSCAPE IRRIGATION

SYMBOL	MANUFACTURER/MODEL/DESCRIPTION
	Irrigation Lateral Line: PVC Class 200 SDR 21 PVC Class 200 Recycled Water Purple Lateral Pipe. Only lateral transition pipe sizes 1" and above are indicated on the plan, with all others being 3/4" in size.

SYMBOL	MANUFACTURER/MODEL/DESCRIPTION
	Irrigation Mainline: PVC Schedule 40 and Class 315 PVC - Recycled Water Purple Mainline Schedule 40 to 1-1/2", PVC Class 315 SDR 13.5 for pipes 2" and larger.

SYMBOL	MANUFACTURER/MODEL/DESCRIPTION
	Irrigation Mainline: Existing Mainline to be relocated. Contractor to relocate existing mainline behind new street curb or sidewalk. Contractor to verify size of existing mainline and replace with same size (Minimum 2").

SYMBOL	MANUFACTURER/MODEL/DESCRIPTION
	Irrigation Mainline: Existing Mainline to Remain Contractor to protect in place. If damaged during construction contractor to repair and or replace.

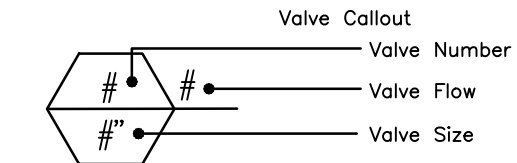

NOTE:

- CONTRACTOR TO INSTALL OVERHEAD SPRAY SPRINKLERS 24" & ROTARY HEADS 12" AWAY FROM NON-PERMEABLE PAVING EXCEPT WHERE EXISTING TURF IS LOCATED. WHERE EXISTING TURF IS LOCATED LOCATE HEADS 6" AWAY FROM NON-PERMEABLE PAVING.

SUBSURFACE DRIPLINE NOTES:

- SUBSURFACE DRIP SYMBOL (HATCH) IS DIAGRAMMATIC AND DOES NOT REFLECT ACTUAL QUANTITY OF TUBING. REFER TO SUBSURFACE DRIPLINE DETAILS ON SHEET 5
- ALL TREES IN DRIP AREAS TO RECEIVE DRIP RINGS SEE SHEET 5 DETAIL 7
- ALL 15 GAL. AND SMALLER SHRUBS / GROUND COVER TO RECEIVE DRIPLINE ON EACH SIDE OF ROOTBALL WITH A MAXIMUM SPACING BETWEEN LINES OF 18". ALL DRIP LINE TO BE BURIED 2" BELOW GRADE.
- CONTRACTOR TO INSTALL THE FOLLOWING EQUIPMENT WITH SUBSURFACE DRIPLINE:  
TORO DRIP FLUSH CAP IN A ROUND VALVE BOX - LOCATE AT BOTH ENDS OF THE SYSTEM

CONTRACTOR TO INSTALL (1) RAINBIRD AIR/VACUUM RELIEF VALVE IN A ROUND VALVE BOX AT THE HIGHEST ELEVATION OF EACH PLANTER IN EACH VALVE SYSTEM WHERE SUBSURFACE DRIP LINE IS USED. WHEN A SUBSURFACE DRIP VALVE SERVICES SEPARATE PLANTERS, EACH MUST HAVE ITS OWN RELIEF VALVE.

NOTE: CONTRACTOR TO UTILIZE EXISTING IRRIGATION SYSTEM TO IRRIGATE PROPOSED TREES. CONTRACTOR TO REPAIR EXISTING SYSTEM WHERE NECESSARY IN ORDER TO IRRIGATE TREES.

CITY OF INDUSTRY

APPROVED BY:	DATE
CLEMENT N. CALVILLO, PE, RCE 27743	DEPUTY CITY ENGINEER

SAN JOSE AVENUE RECONSTRUCTION  
FROM CHARLIE RD. TO NOGALES STREET

IRRIGATION LEGEND / NOTES

DESIGNED BY:	CHECKED BY:	JOB NO. CITY - MP 08-09	SHT. 4 OF 14
DRAFTED BY:	DATE: APRIL 12, 2022		



NO.	DATE	REVISIONS	CK.	BY

CITY OF INDUSTRY  
INCORPORATED JUNE 18, 1957  
P.O. Box 3366, City of Industry, California 91744  
Administrative Offices: 15625 Mayor Dave Way (626) 333-2211

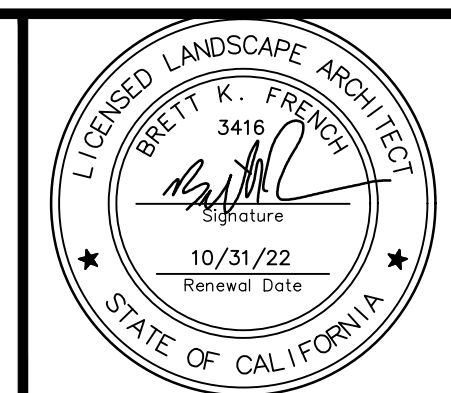

Prepared by: **Environs INC**  
LANDSCAPE ARCHITECTURE  
Creating Sustainable & Water Conserving Solutions  
801 El Berrero • San Clemente, CA 92672  
PH: (949) 636-4663

BRETT FRENCH, RLA #3416 DATE: 4-12-22  
DESIGN BY: BKF DRAWN BY: BKF

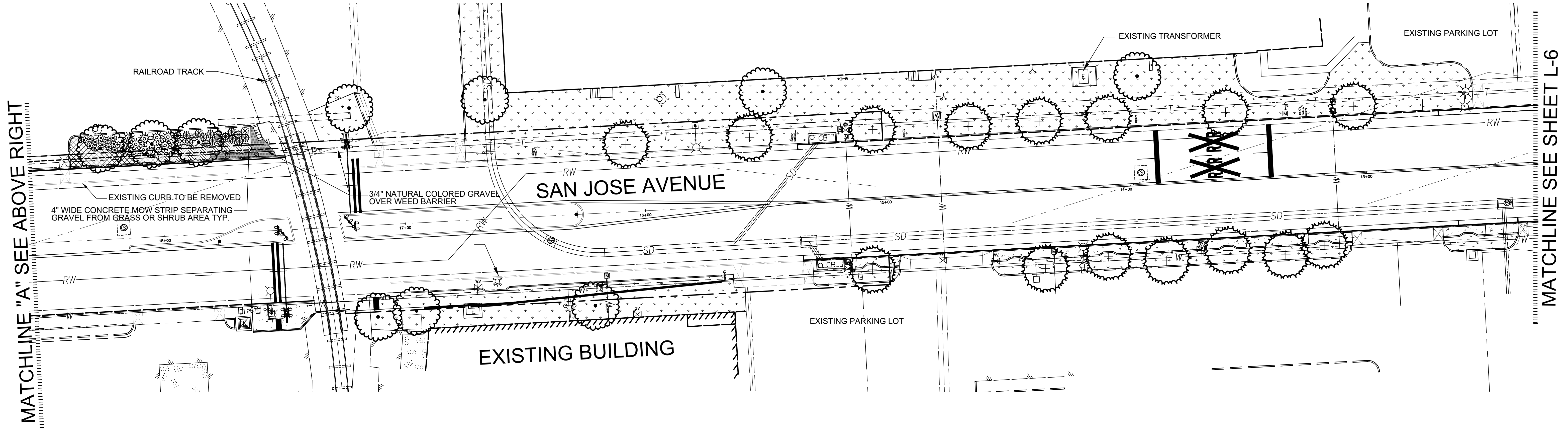
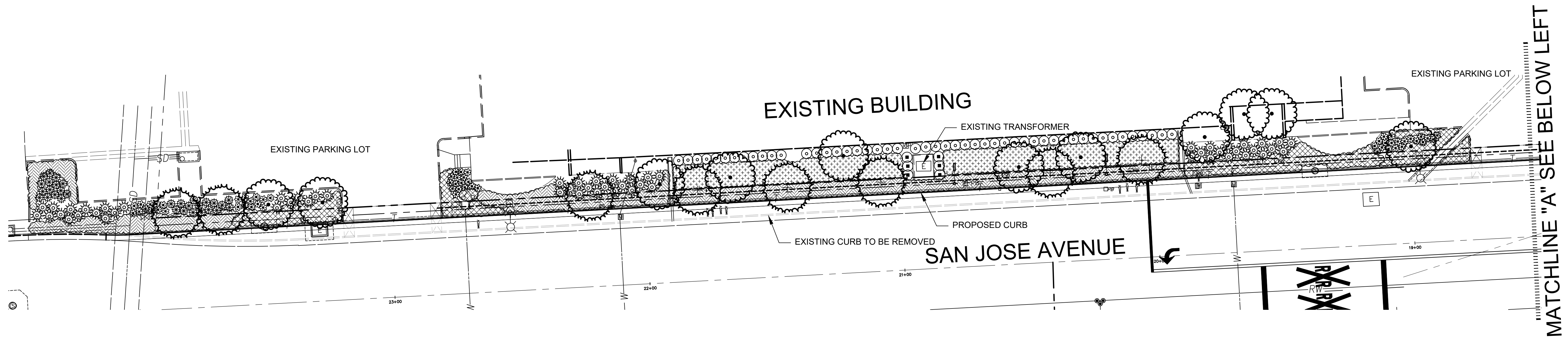

NOTE: FOR PLANTING LEGEND SEE SHEET 7

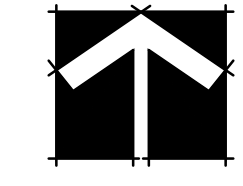
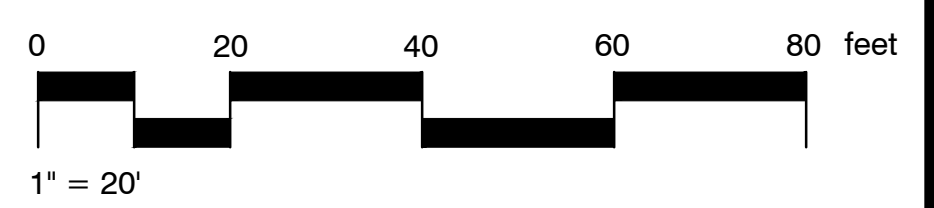

NORTH  
SCALE 1" = 20'-0"

CITY OF INDUSTRY

APPROVED BY: \_\_\_\_\_  
CLEMENT N. CALVILLO, PE, RCE 27743 DEPUTY CITY ENGINEER DATE \_\_\_\_\_

SAN JOSE AVENUE RECONSTRUCTION  
FROM CHARLIE RD. TO NOGALES STREET

PLANTING PLAN

DESIGNED BY: \_\_\_\_\_ CHECKED BY: \_\_\_\_\_  
DRAFTED BY: \_\_\_\_\_ DATE: APRIL 12, 2022

JOB NO. CITY - MP 08-09 SHT. 5 OF 14  
CONTRACT DRAWING OF \_\_\_\_\_



NO.	DATE	REVISIONS	CK. BY



CITY OF INDUSTRY

INCORPORATED JUNE 18, 1957  
P.O. Box 3366, City of Industry, California 91744  
Administrative Offices: 15625 Mayor Dave Way  
(626) 333-2211



Prepared by: **Environs** Inc.  
LANDSCAPE ARCHITECTURE  
Creating Sustainable & Water Conserving Solutions  
801 El Berro • San Clemente, CA 92672  
PH. (949) 626-4663  
Signature: \_\_\_\_\_  
DATE: 4-12-22  
DESIGN BY: BKF #3416 RLA DATE: \_\_\_\_\_  
DRAWN BY: BKF

MATCHLINE SEE SHEET L-5

MATCHLINE SEE "A" THIS SHEET

MATCHLINE SEE "A" THIS SHEET

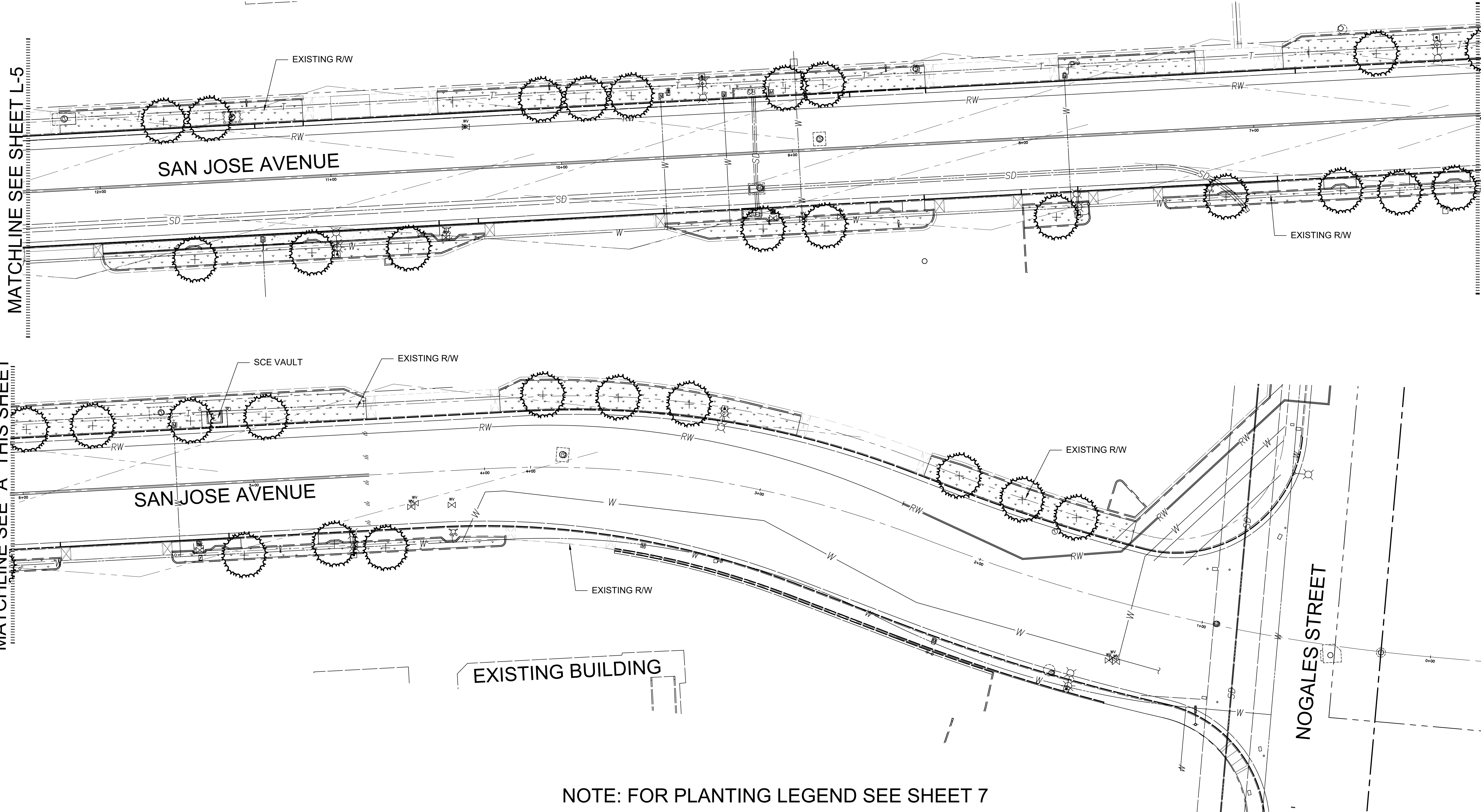

NOTE: FOR PLANTING LEGEND SEE SHEET 7

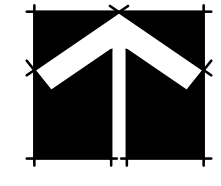
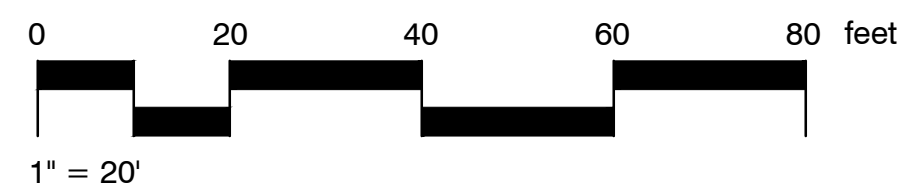

NORTH

SCALE 1" = 20'-0"

CITY OF INDUSTRY

APPROVED BY: \_\_\_\_\_ DATE: \_\_\_\_\_  
 CLEMENT N. CALVILLO, PE, RCE 27743 DEPUTY CITY ENGINEER

SAN JOSE AVENUE RECONSTRUCTION FROM CHARLIE RD. TO NOGALES STREET

PLANTING PLAN

DESIGNED BY: \_\_\_\_\_ CHECKED BY: \_\_\_\_\_ DATE: 4-12-22  
 DRAFTED BY: \_\_\_\_\_ DATE: APRIL 12, 2022

JOB NO. CITY - MP 08-09

SHT. 6 OF 14

CONTRACT DRAWING OF



NO.	DATE	REVISIONS	CK. BY



CITY OF INDUSTRY

INCORPORATED JUNE 18, 1957  
 P.O. Box 3366, City of Industry, California 91744  
 Administrative Offices: 15625 Mayor Dave Way  
 (626) 333-2211



Prepared by: **Environs Inc**  
 LANDSCAPE ARCHITECTURE  
 Creating Sustainable & Water Conserving Solutions  
 801 El Berro • San Clemente, CA 92672  
 PH. (949) 626-4663

BRETT FRENCH, RLA #3416 DATE: 4-12-22  
 DESIGN BY: BKF DRAWN BY: BKF

## PLANT SCHEDULE

TREES	BOTANICAL / COMMON NAME	CONT	WUCOLS	QTY	
	Existing Tree to Remain- Protect in Place	Existing		21	
	Lagerstroemia x 'Muskogee' / Lavender Crape Myrtle Std.	24"box	Med	54	
SHRUBS	BOTANICAL / COMMON NAME	CONT	WUCOLS	QTY	
	Aloe striata / Coral Aloe	5 gal	Low	70	
	Bougainvillea x 'Rosenka' / Bougainvillea	5 gal	Low	69	
	Dodonaea viscosa 'Purpurea' / Purple Leafed Hopseed Bush	5 gal	LOW	6	
	Leucophyllum frutescens 'Green Cloud' TM / Green Cloud Texas Ranger	5 gal	Low	49	
	Muhlenbergia capillaris 'Autumn Blush' / Pink Muhly	5 gal	Low	50	
SHRUB AREAS	BOTANICAL / COMMON NAME	CONT	WUCOLS	SPACING	QTY
	EXISTING SHRUBS & GROUND COVER / TO REMAIN - PROTECT IN PLACE	Existing			26,895 sf
GROUND COVERS	BOTANICAL / COMMON NAME	CONT	WUCOLS	SPACING	QTY
	Acacia redolens 'Desert Carpet' TM / Bank Catclaw	1 gal	LOW	48" o.c.	112
	Lantana montevidensis 'New Gold' / Trailing Lantana	1 gal	LOW	36" o.c.	179
	Lonicera japonica 'Halliana' / Halls Honeysuckle Flowering Vine	1 gal	Low	36" o.c.	294

### NOTE:

- ALL TREES WITHIN 8' OF HARDSCAPE SHALL BE IN A SHAWTOWN LINEAR (WRAP AROUND NOT ALLOWED) ROOT BARRIER 24" HIGH LINEAR ROOT BARRIER SHALL BE CENTERED ON TREE AND EXTEND 5' IN BOTH DIRECTIONS FOR A TOTAL OF 10'
- NOTE: QUANTITIES AND AREA CALCULATIONS SHOWN IN LEGEND ARE FOR REFERENCE ONLY. CONTRACTOR RESPONSIBLE FOR ALL QUANTITY TAKE-OFFS AND AREA CALCULATIONS FOR DETERMINING COST AND DELIVERY OF MATERIALS TO SITE. NOTE AREA CALCULATIONS DO NOT REFLECT SLOPE FACTORS.

**SHREDDED MULCH NOTE**  
ALL PLANTER AREAS TO RECEIVE A 3" LAYER OF SHREDDED COVER MULCH AVAILABLE FROM EARTHWORKS (951)782-0260

<b>CITY OF INDUSTRY</b>			
APPROVED BY: _____			
CLEMENT N. CALVILLO, PE, RCE 27743		DEPUTY CITY ENGINEER	
DATE: _____			
<b>SAN JOSE AVENUE RECONSTRUCTION FROM CHARLIE RD. TO NOGALES STREET</b>			
<b>PLANTING LEGEND / NOTES</b>			
DESIGNED BY: _____	CHECKED BY: _____	JOB NO. CITY - MP 08-09	SHT. 7 OF 14
DRAFTED BY: _____	DATE: APRIL 12, 2022		
CONTRACT DRAWING OF _____			

NO.	DATE	REVISIONS	CK. BY



**CITY OF INDUSTRY**

INCORPORATED JUNE 18, 1957  
P.O. Box 3366, City of Industry, California 91744  
Administrative Offices: 15625 Mayor Dave Way  
(626) 333-2211

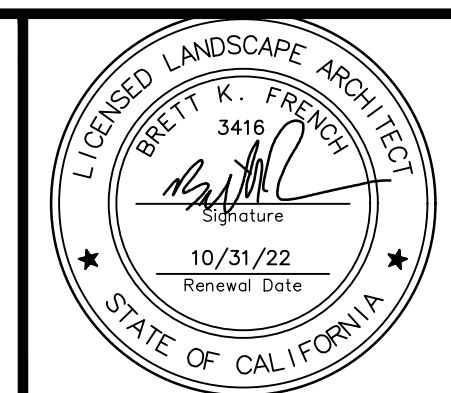

LICENSED LANDSCAPE ARCHITECT  
BRETT K. FRENCH  
3416  
10/31/22  
RENEWAL DATE  
STATE OF CALIFORNIA

Prepared by: **Environs Inc**  
LANDSCAPE ARCHITECTURE  
Creating Sustainable & Water Conserving Solutions  
801 El Berrero • San Clemente, CA 92672  
PH. (949) 626-4663

Signature: \_\_\_\_\_ DATE: 4-12-22  
BRETT FRENCH, RLA #3416  
DESIGN BY: BKF DRAWN BY: BKF



**811**  
Know what's below.  
Call before you dig.

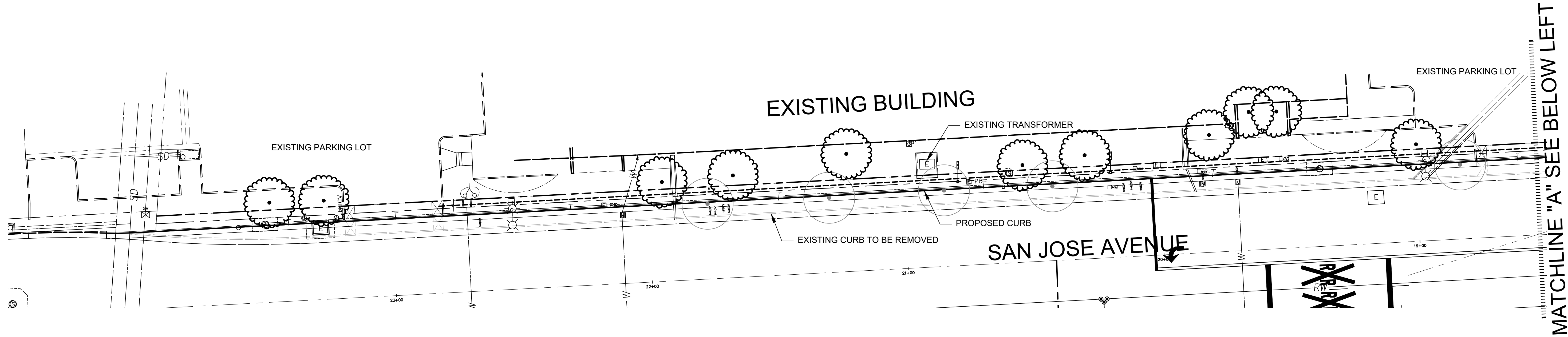

MATCHLINE "A" SEE BELOW LEFT

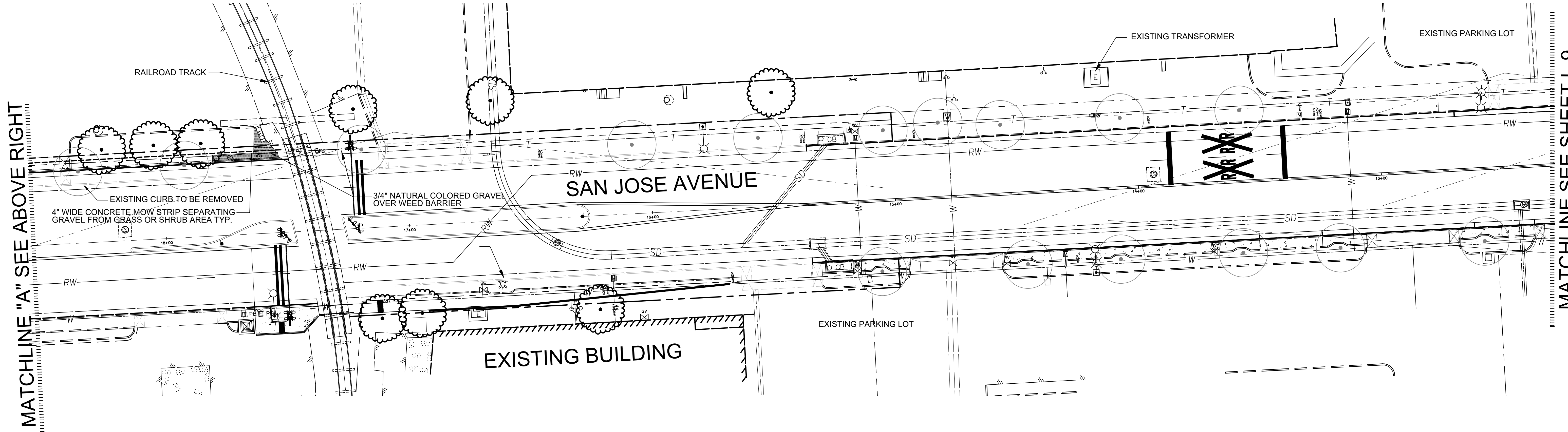

MATCHLINE "A" SEE ABOVE RIGHT

MATCHLINE SEE SHEET L-9

**PLANT SCHEDULE**

TREES	BOTANICAL / COMMON NAME	CONT	QTY
	Existing Tree To Be Removed	Existing	49
	Existing Tree to Remain- Protect in Place	Existing	21

NOTE: FOR PLANTING LEGEND SEE SHEET 7

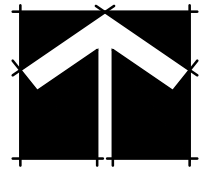
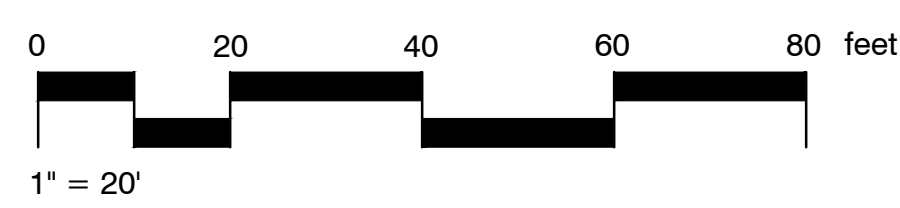

NORTH  
SCALE 1" = 20'-0"

**CITY OF INDUSTRY**

APPROVED BY: \_\_\_\_\_  
CLEMENT N. CALVILLO, PE, RCE 27743 DEPUTY CITY ENGINEER DATE: \_\_\_\_\_

**SAN JOSE AVENUE RECONSTRUCTION  
FROM CHARLIE RD. TO NOGALES STREET**

**EXISTING TREE PLAN**

DESIGNED BY: _____	CHECKED BY: _____	JOB NO. CITY - MP 08-09	SHT. 8 OF 14
DRAFTED BY: _____	DATE: APRIL 12, 2022		



NO.	DATE	REVISIONS	CK. BY



**CITY OF INDUSTRY**  
 INCORPORATED JUNE 18, 1957  
 P.O. Box 3366, City of Industry, California 91744  
 Administrative Offices: 15625 Mayor Dave Way  
 (626) 333-2211



Prepared by: **Environs INC**  
**LANDSCAPE ARCHITECTURE**  
 Creating Sustainable & Water Conserving Solutions  
 801 El Berro • San Clemente, CA 92672  
 PH: (949) 626-4663

Signature: \_\_\_\_\_  
 4-12-22  
 BRETT FRENCH, RLA #3416 DATE  
 DESIGN BY: BKF DRAWN BY: BKF

CONTRACT DRAWING OF

MATCHLINE SEE SHEET L-8

MATCHLINE SEE "A" THIS SHEET

MATCHLINE SEE "A" THIS SHEET

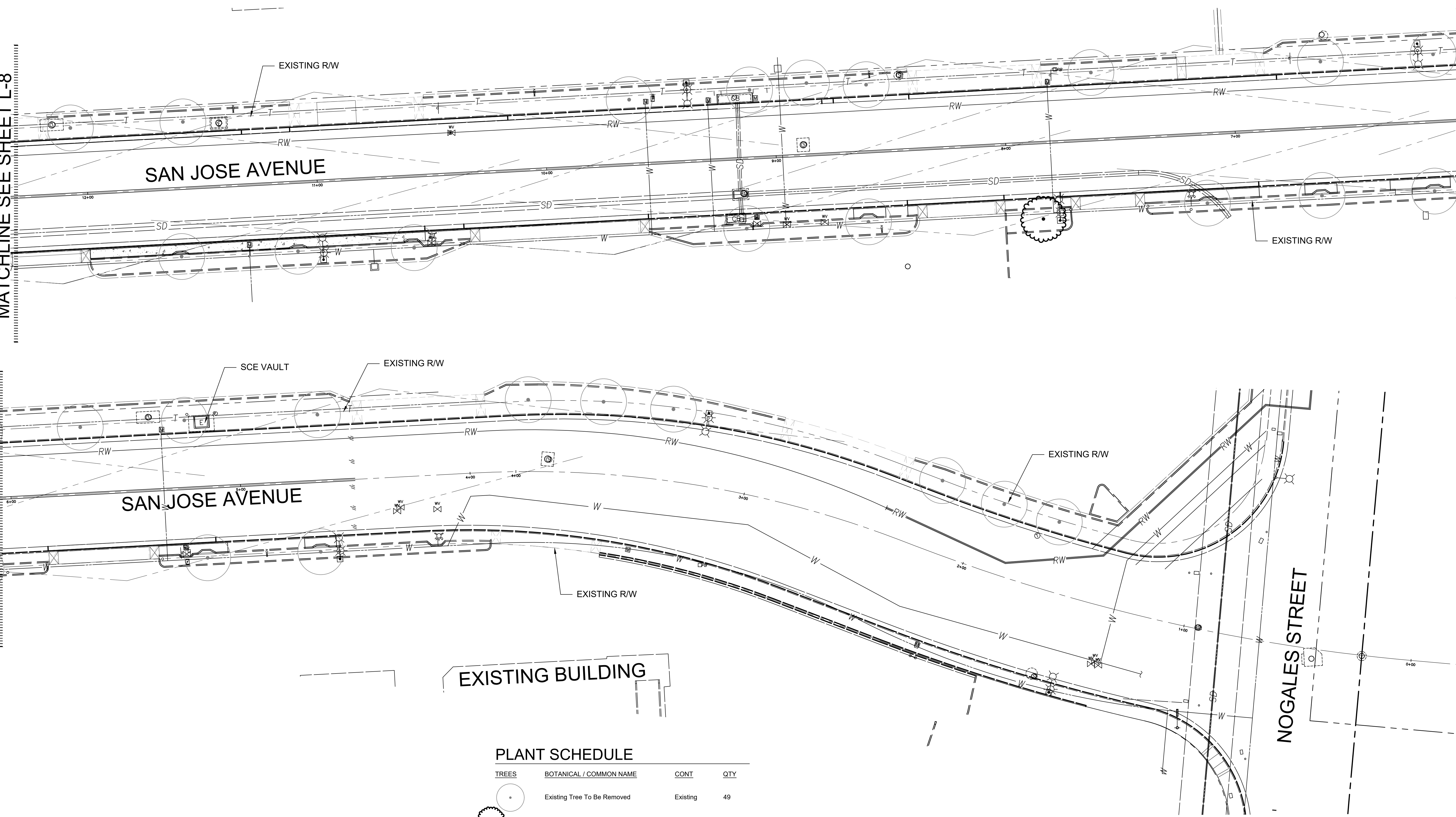

PLANT SCHEDULE

TREES	BOTANICAL / COMMON NAME	CONT	QTY
	Existing Tree To Be Removed	Existing	49
	Existing Tree to Remain- Protect in Place	Existing	21

NOTE: FOR PLANTING LEGEND SEE SHEET 7

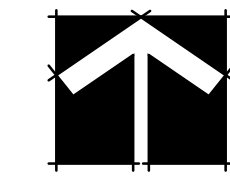
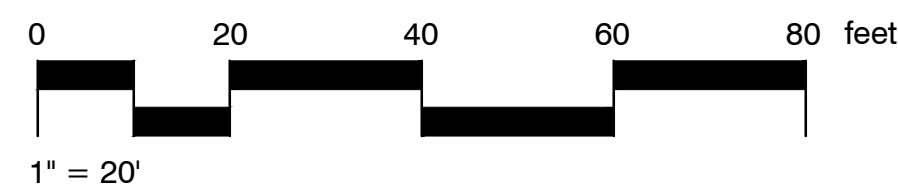

SCALE 1" = 20'-0"

CITY OF INDUSTRY

APPROVED BY: \_\_\_\_\_ DATE: \_\_\_\_\_  
 CLEMENT N. CALVILLO, PE, RCE 27743 DEPUTY CITY ENGINEER

SAN JOSE AVENUE RECONSTRUCTION  
 FROM CHARLIE RD. TO NOGALES STREET

EXISTING TREE PLAN

DESIGNED BY: \_\_\_\_\_ CHECKED BY: \_\_\_\_\_ DATE: 4-12-22  
 DRAFTED BY: \_\_\_\_\_ DATE: APRIL 12, 2022

JOB NO. CITY - MP 08-09

SHT. 9 OF 14

CONTRACT DRAWING OF



NO.	DATE	REVISIONS	CK. BY



CITY OF INDUSTRY

INCORPORATED JUNE 18, 1957  
 P.O. Box 3366, City of Industry, California 91744  
 Administrative Offices: 15625 Mayor Dave Way  
 (626) 333-2211

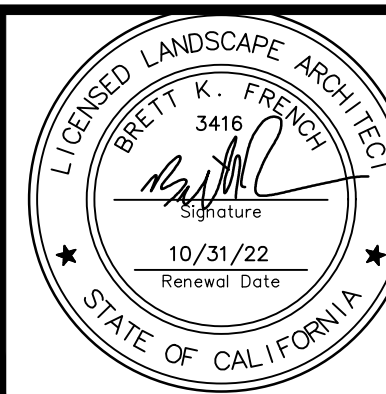

Prepared by: **Environs Inc**  
 LANDSCAPE ARCHITECTURE  
 Creating Sustainable & Water Conserving Solutions  
 801 El Berro • San Clemente, CA 92672  
 PH: (949) 626-4663

BRETT FRENCH, RLA #3416 DATE: 4-12-22  
 DESIGN BY: BKF DRAWN BY: BKF

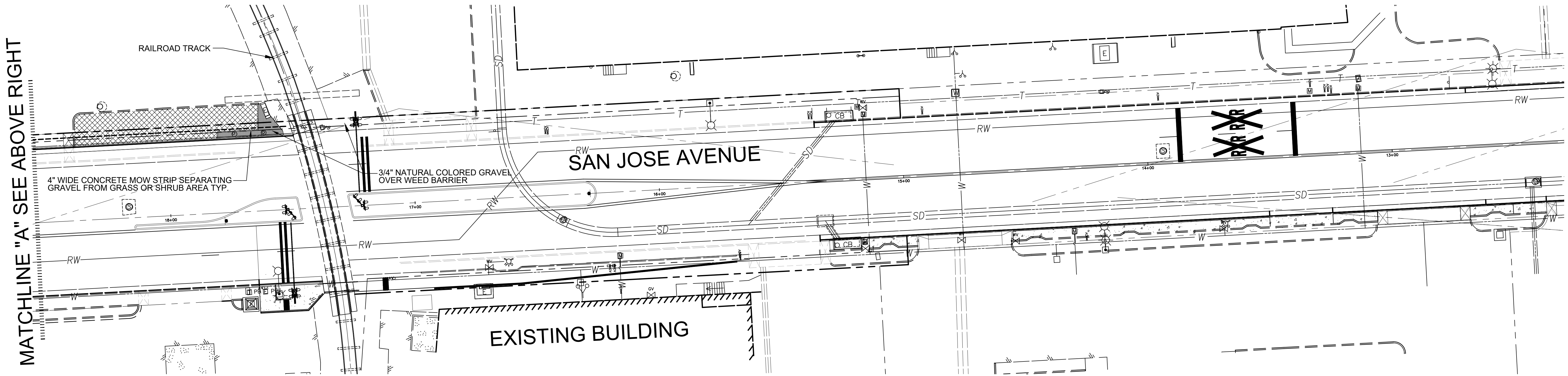
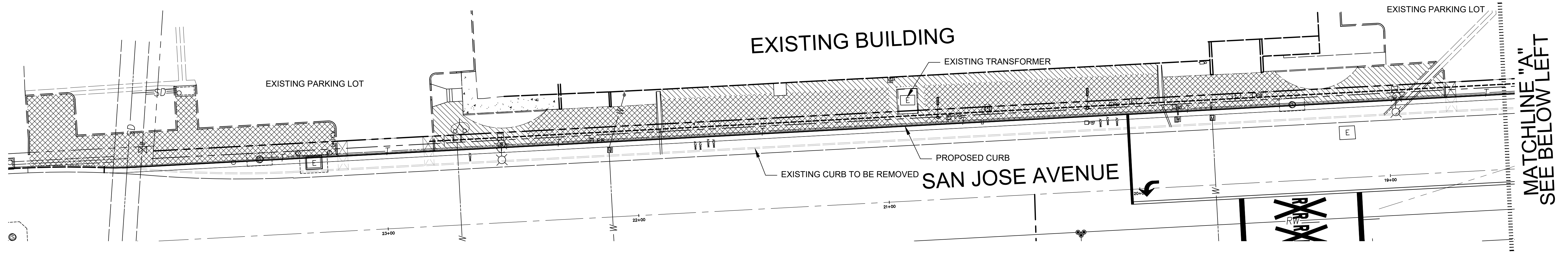

California Water Efficient Landscape Worksheet								
Reference Evapotranspiration (ET <sub>c</sub> )	47.5		Project Type	Non-Residential		0.45		
Hydrozone # / Planting Description <sup>a</sup>	Plant Factor (PF)	Irrigation Method <sup>b</sup>	Irrigation Efficiency (IE) <sup>c</sup>	ETAF (PF/IE)	Landscape Area (Sq. Ft.)	ETAF x Area	Estimated Total Water Use (ETWU) <sup>d</sup>	
<b>Regular Landscape Areas</b>								
Hyd 1-DRIP-LOW	0.3	Drip	0.81	0.37	1890	700	20615	
Hyd 2-OVERHEAD-LOW	0.3	Overhead	0.75	0.40	7073	2829	83320	
			0.75	0.00		0	0	
					Totals	8963	3529	103935
<b>Special Landscape Areas</b>								
				1		0	0	
				1		0	0	
				1		0	0	
				1		0	0	
					Totals	0	0	0
							ETWU Total	103935
							Maximum Allowed Water Allowance (MAWA) <sup>e</sup>	118782

ETAF Calculations	
Regular Landscape Areas	
Total ETAF x Area	3529
Total Area	8963
Average ETAF	0.39

Average ETAF for Regular Landscape Areas must be 0.55 or below for residential areas, and 0.45 or below for non-residential areas.

REFERENCE NOTES SCHEDULE		
SYMBOL	DESCRIPTION	QTY
	HYDROZONE 1 - DRIP IRRIGATION - LOW WATER USE	1,890 sf
	HYDROZONE 2 - OVERHEAD IRRIGATION - LOW WATER USE	7,073 sf

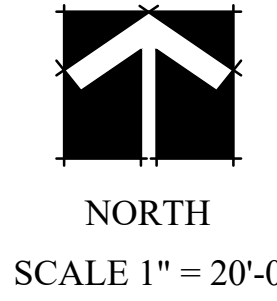
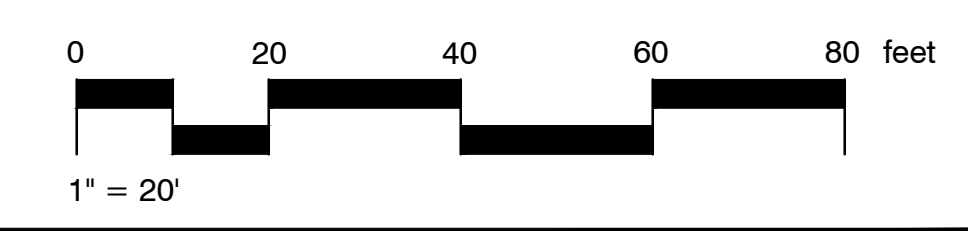

SCALE 1" = 20'-0"

**CITY OF INDUSTRY**

APPROVED BY: \_\_\_\_\_ DATE: \_\_\_\_\_

CLEMENT N. CALVILLO, PE, RCE 27743 DEPUTY CITY ENGINEER

**SAN JOSE AVENUE RECONSTRUCTION FROM CHARLIE RD. TO NOGALES STREET**

**HYDROZONE MAP**

DESIGNED BY: _____	CHECKED BY: _____	JOB NO. CITY - MP 08-09	SHT. 10 OF 14
DRAFTED BY: _____	DATE: APRIL 12, 2022		

CONTRACT DRAWING OF



NO.	DATE	REVISIONS	CK. BY

**CITY OF INDUSTRY**

INCORPORATED JUNE 18, 1957  
P.O. Box 3366, City of Industry, California 91744  
Administrative Offices: 15625 Mayor Dave Way  
(626) 333-2211

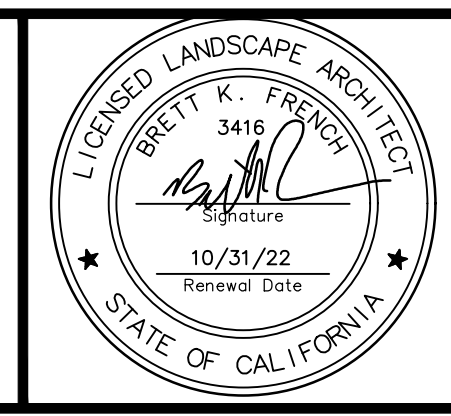

Prepared by: **Environs Inc**  
LANDSCAPE ARCHITECTURE  
Creating Sustainable & Water Conserving Solutions  
801 El Berrero • San Clemente, CA 92672  
PH: (909) 626-4663

BRETT FRENCH, RLA #3416 DATE: 4-12-22  
DESIGN BY: BKF DRAWN BY: BKF

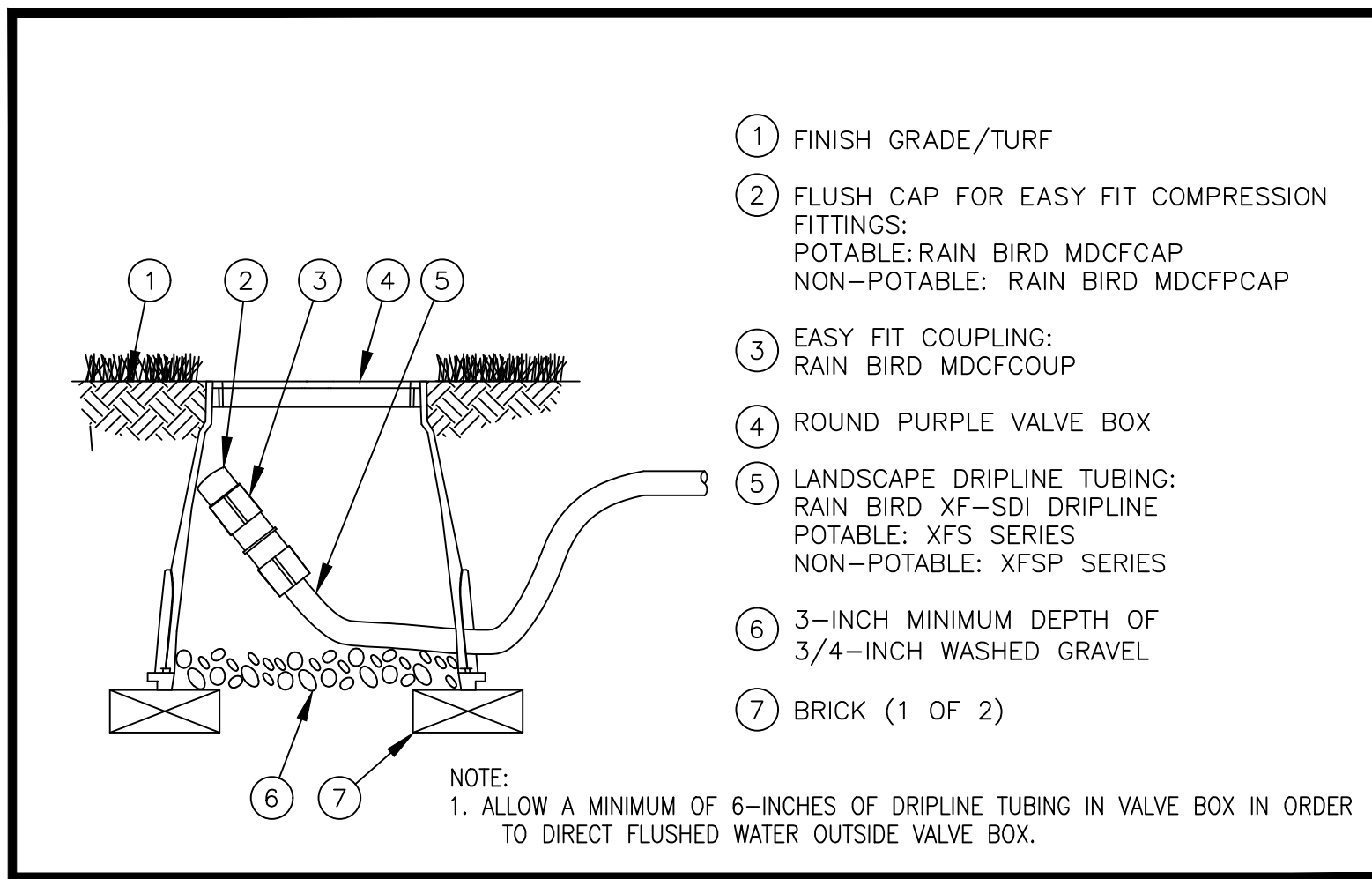

**DRIP FLUSH VALVE** | 10

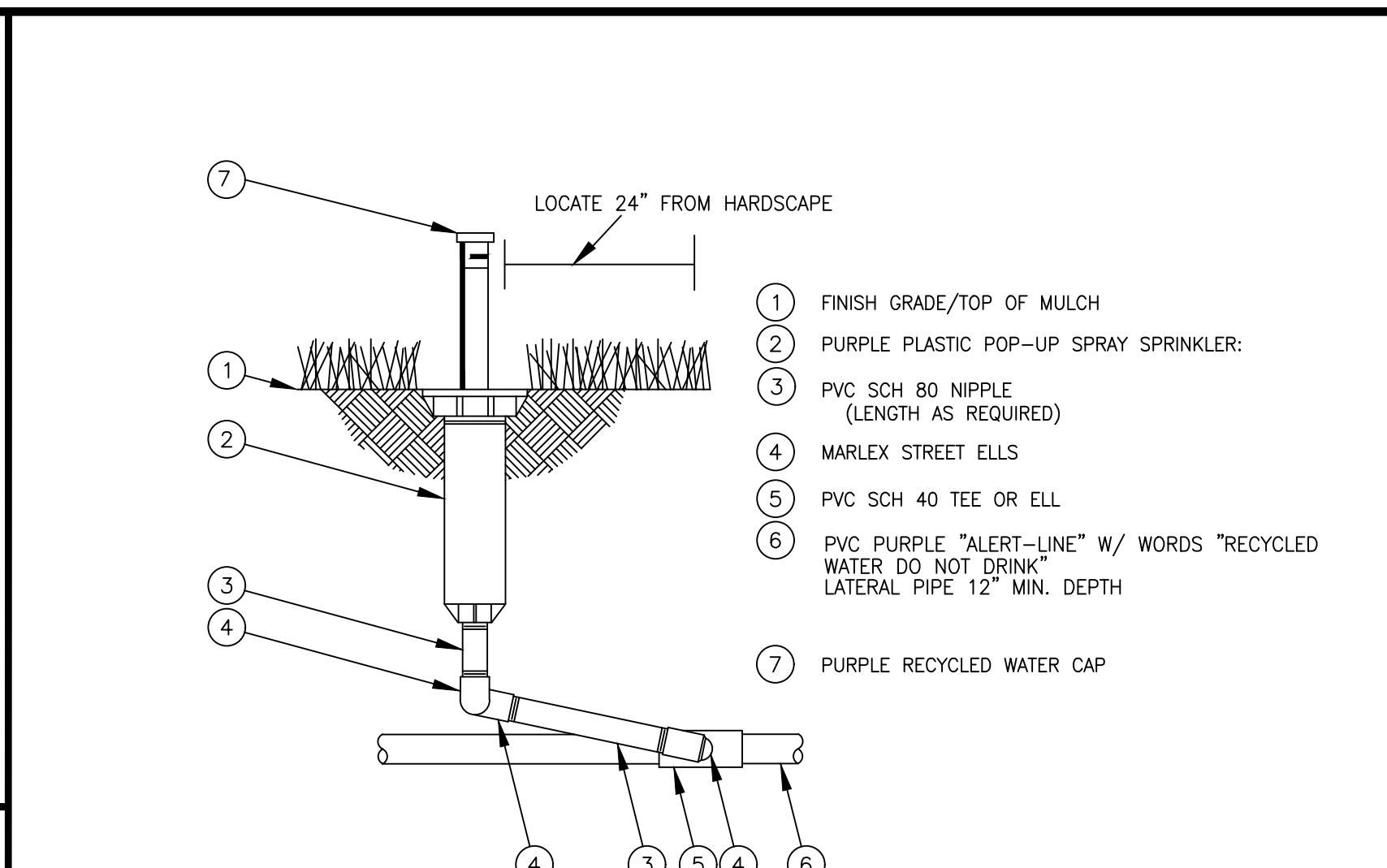

**POP UP SPRAY** | 7

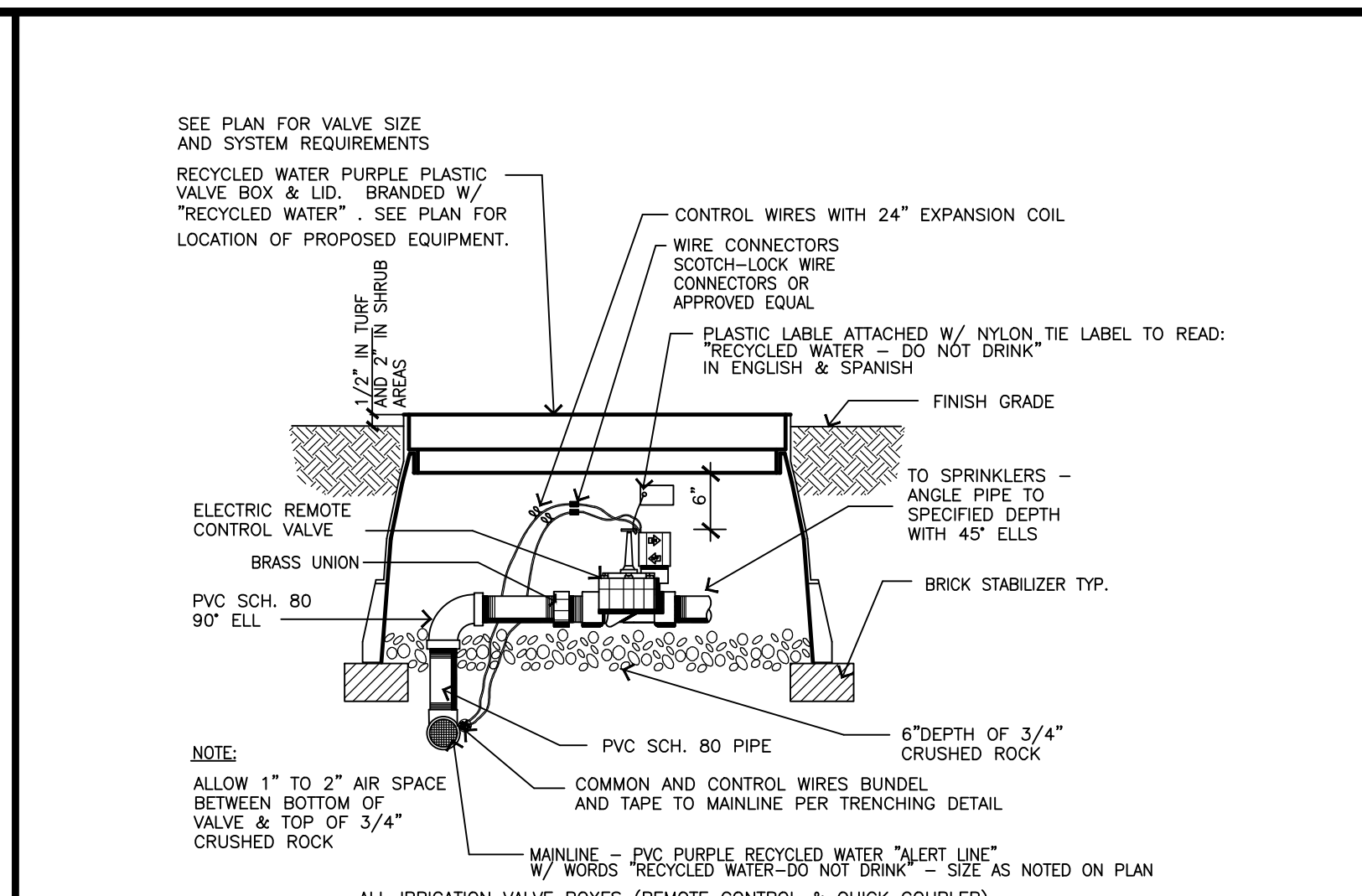

**REMOTE CONTROL VALVE** | 4

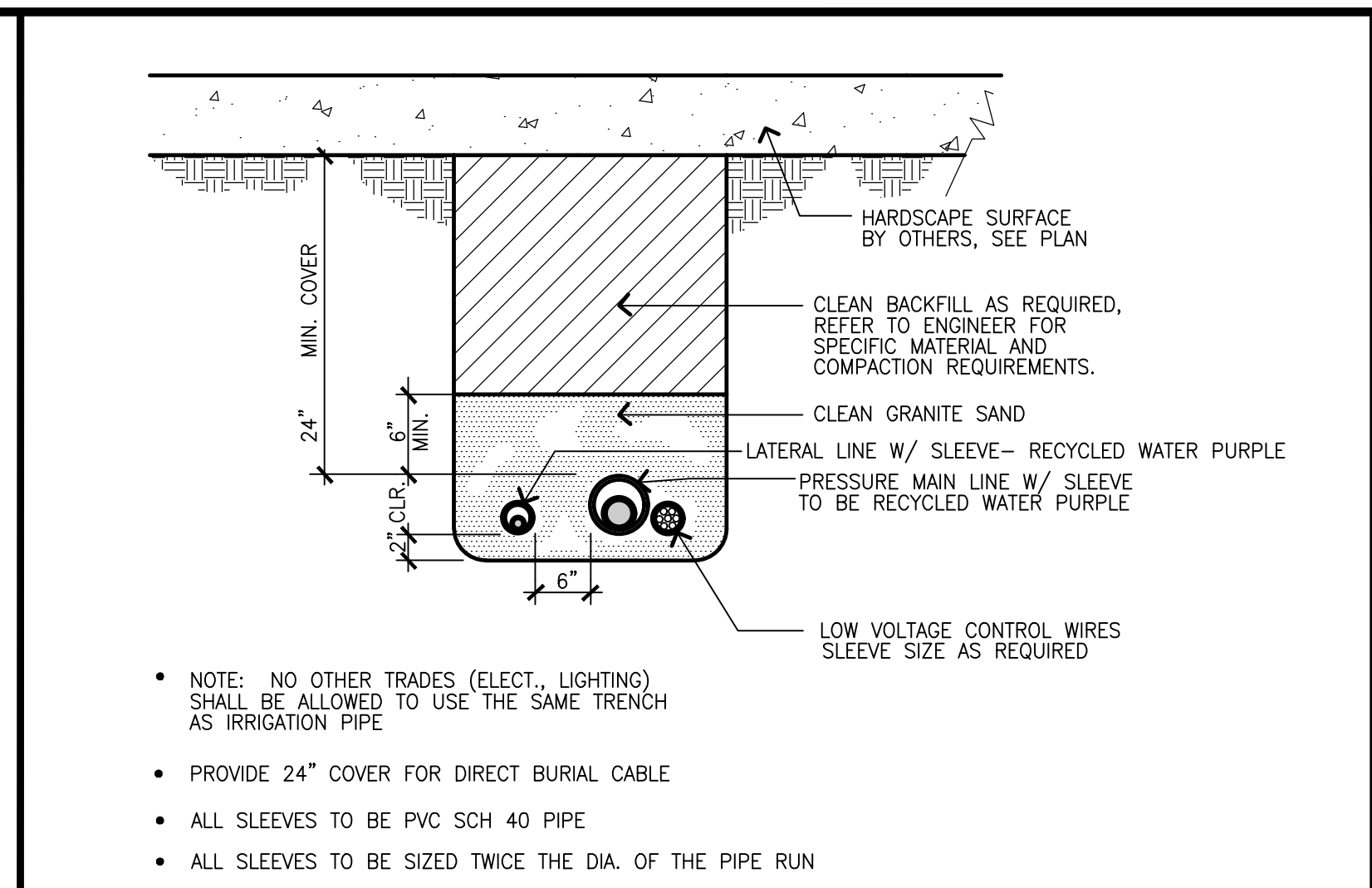

**IRRIGATION SLEEVE DETAIL** | 1

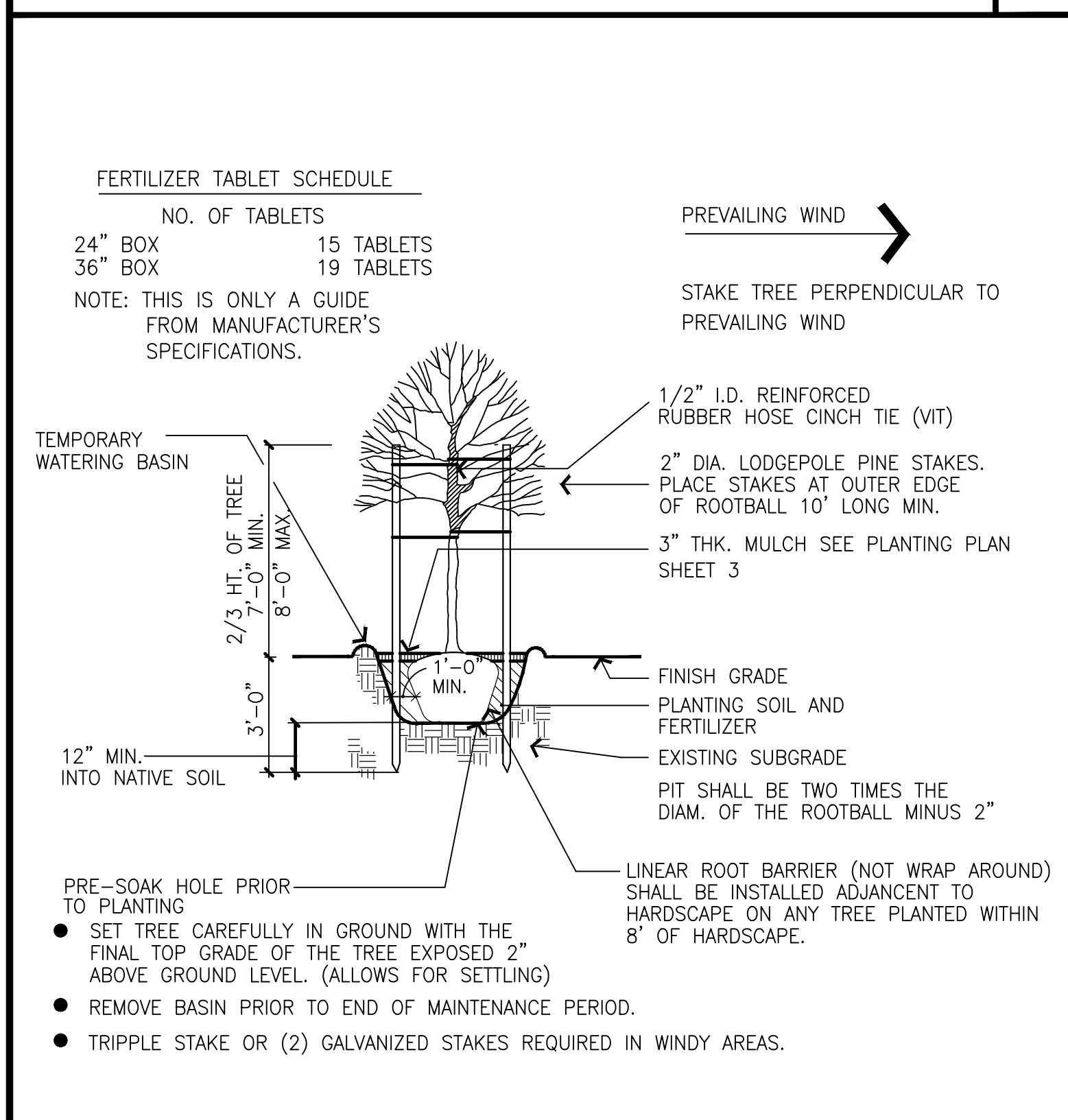

**TREE PLANTING DETAIL** | 11

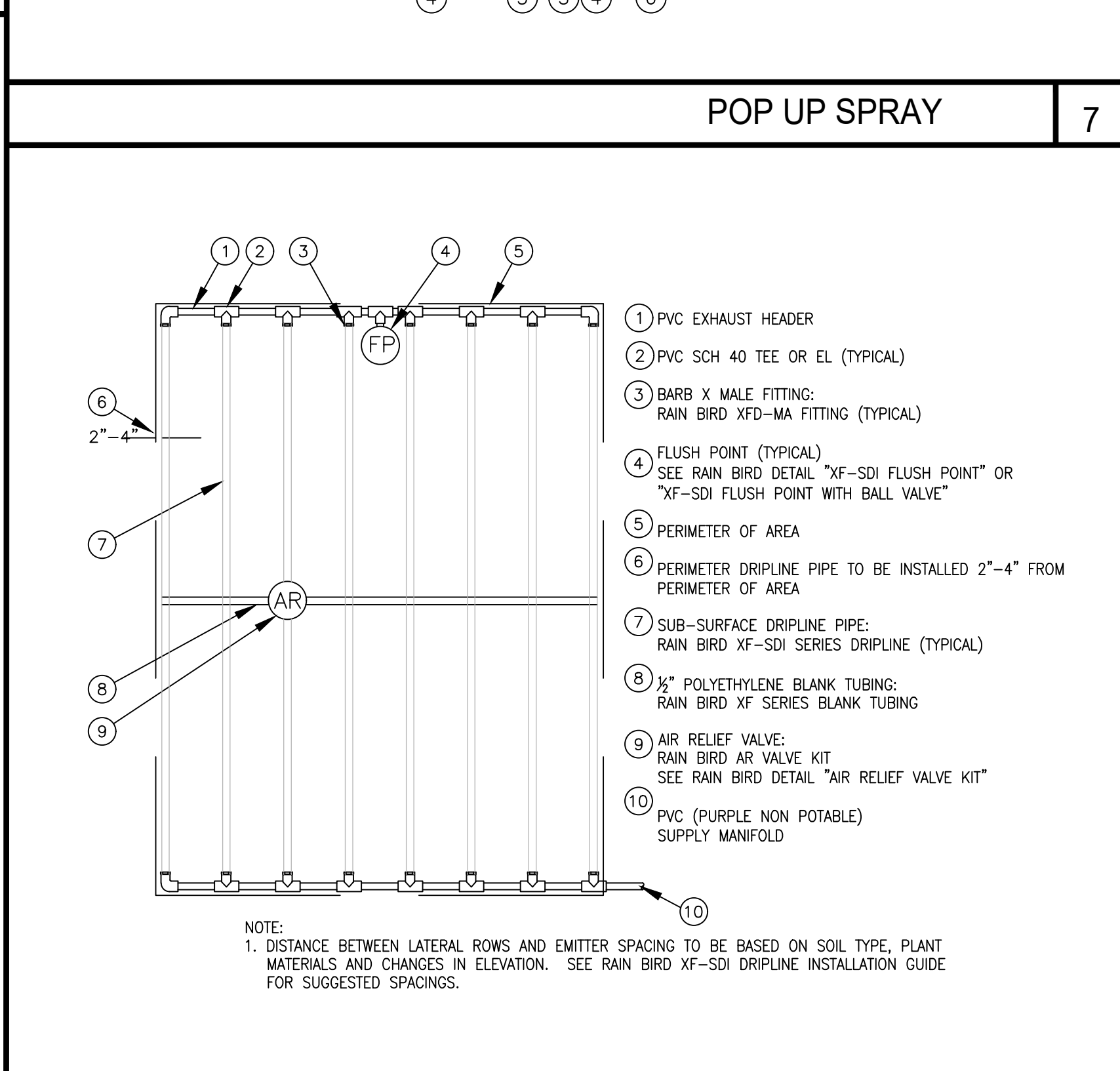

**INLINE DRIP LINE TYPICAL LAYOUT** | 8

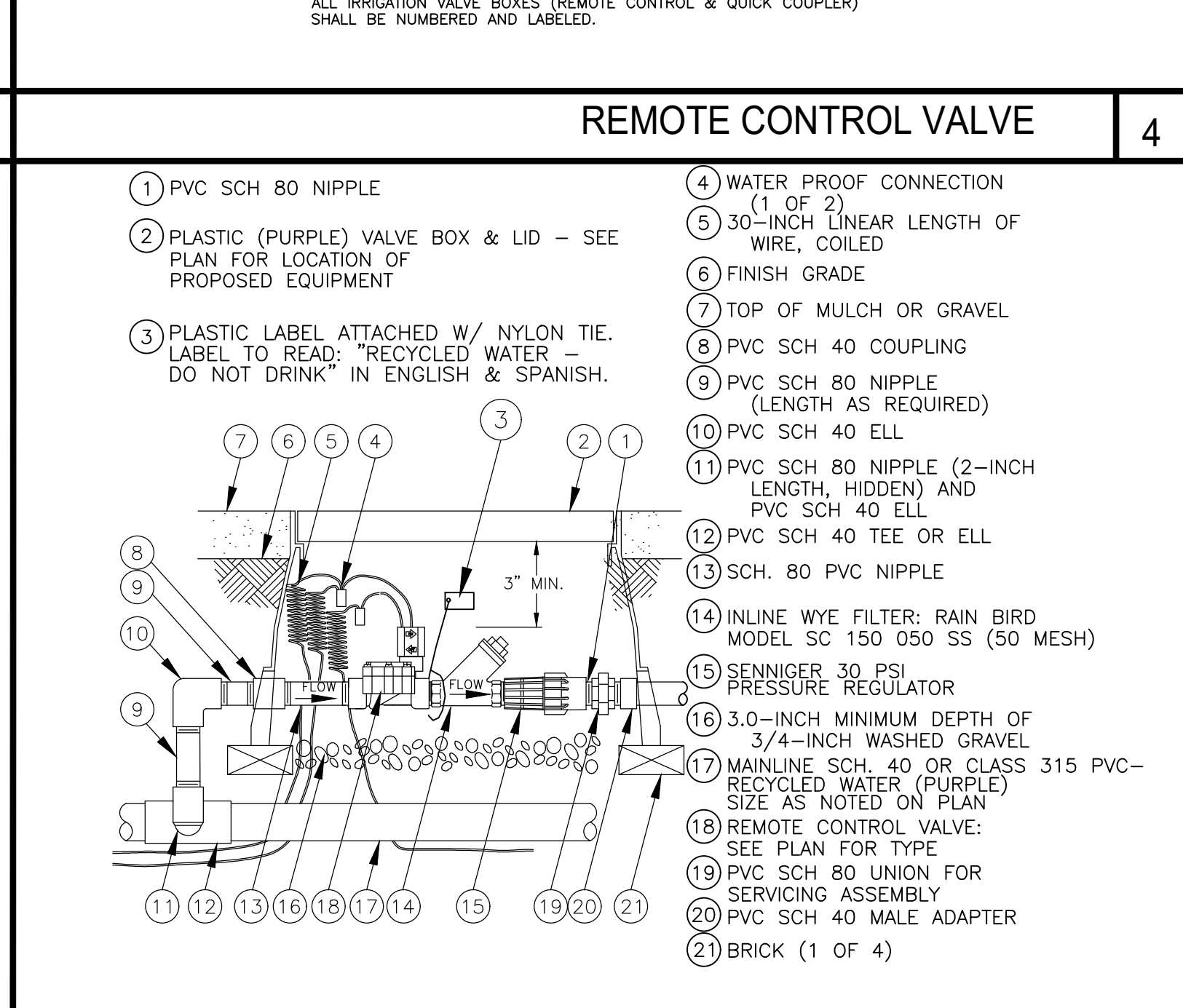

**DRIP IRRIGATION REMOTE CONTROL VALVE** | 5

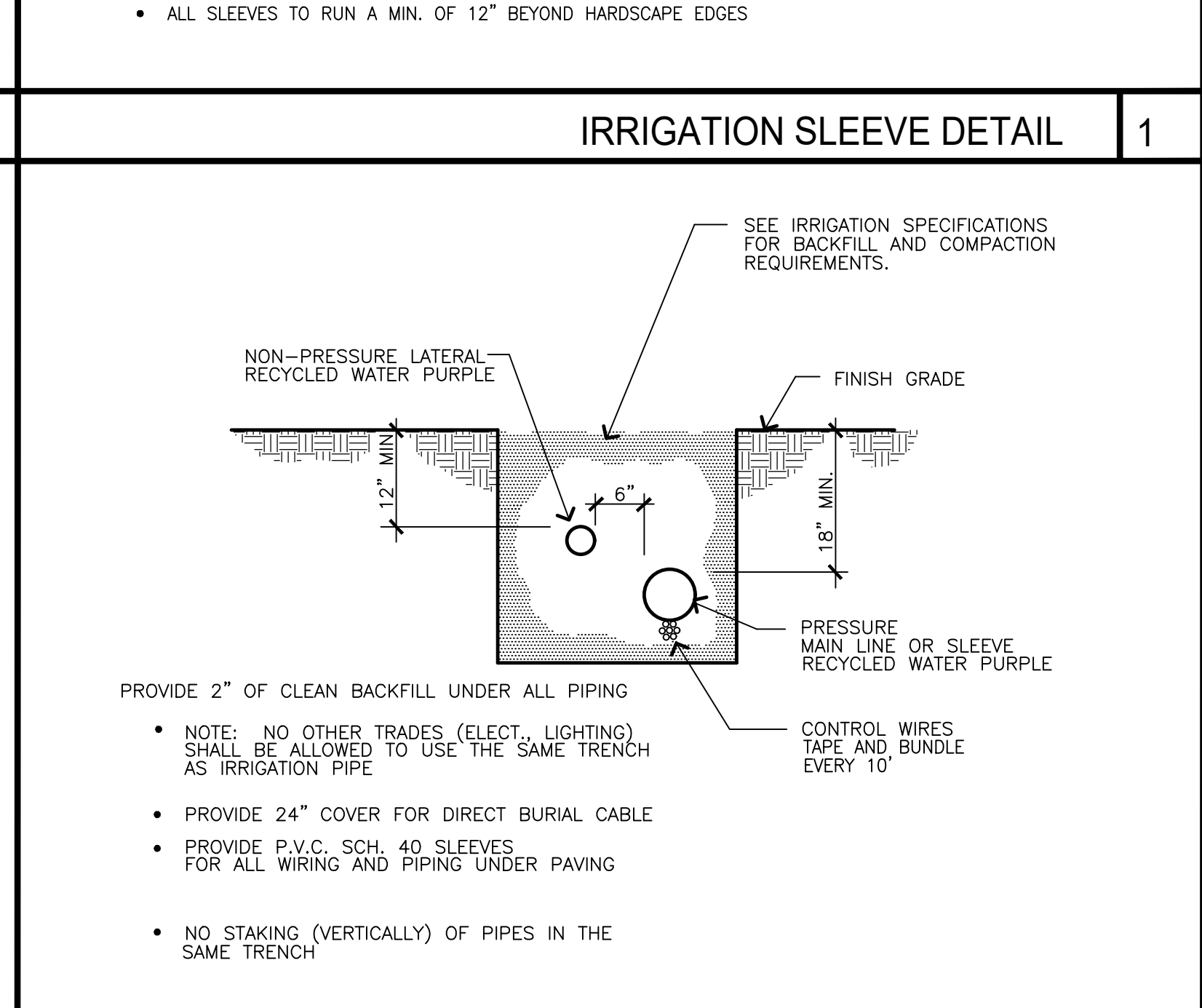

**IRRIGATION TRENCHING DETAIL** | 2

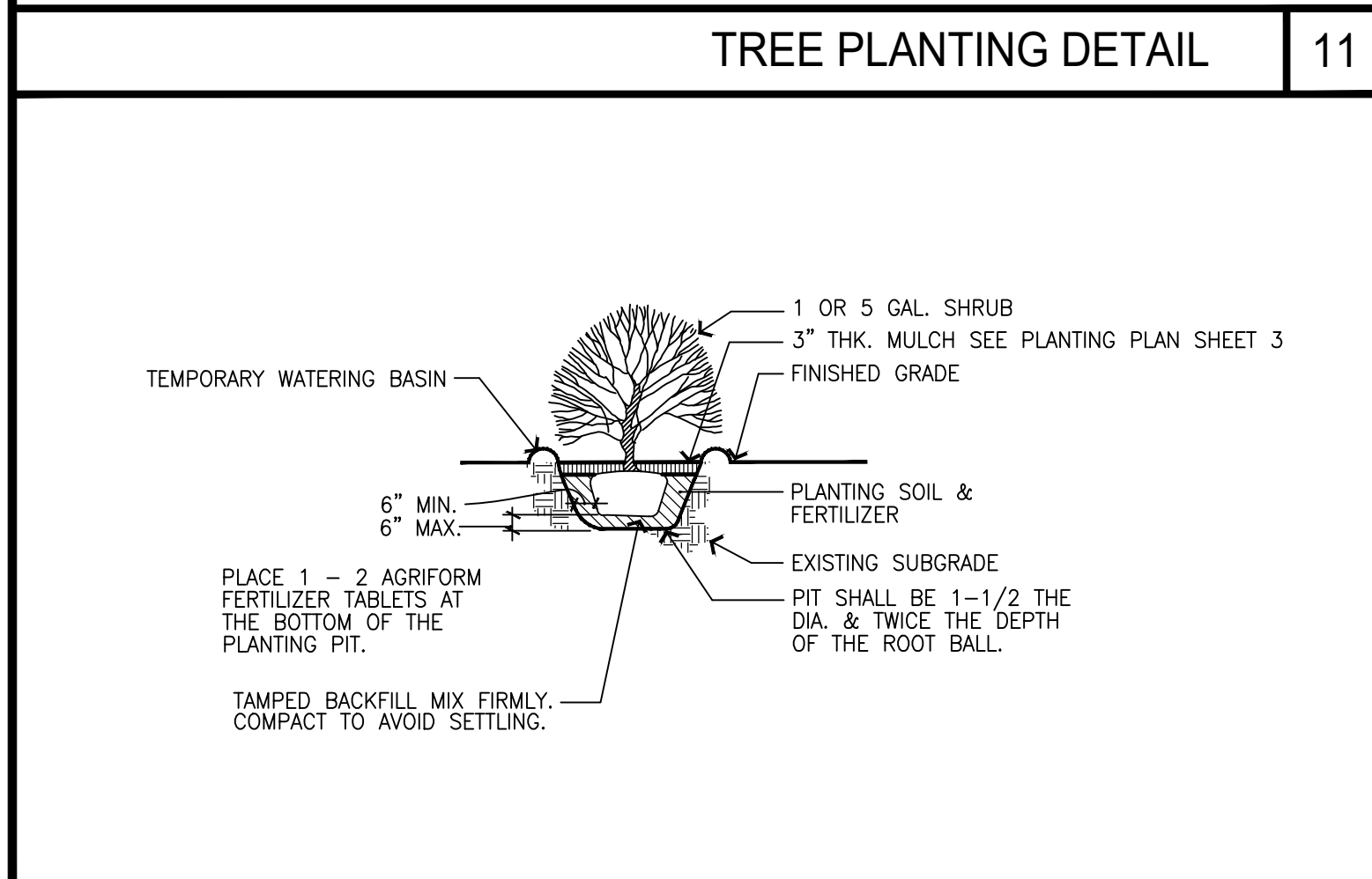

**SHRUB PLANTING DETAIL** | 12

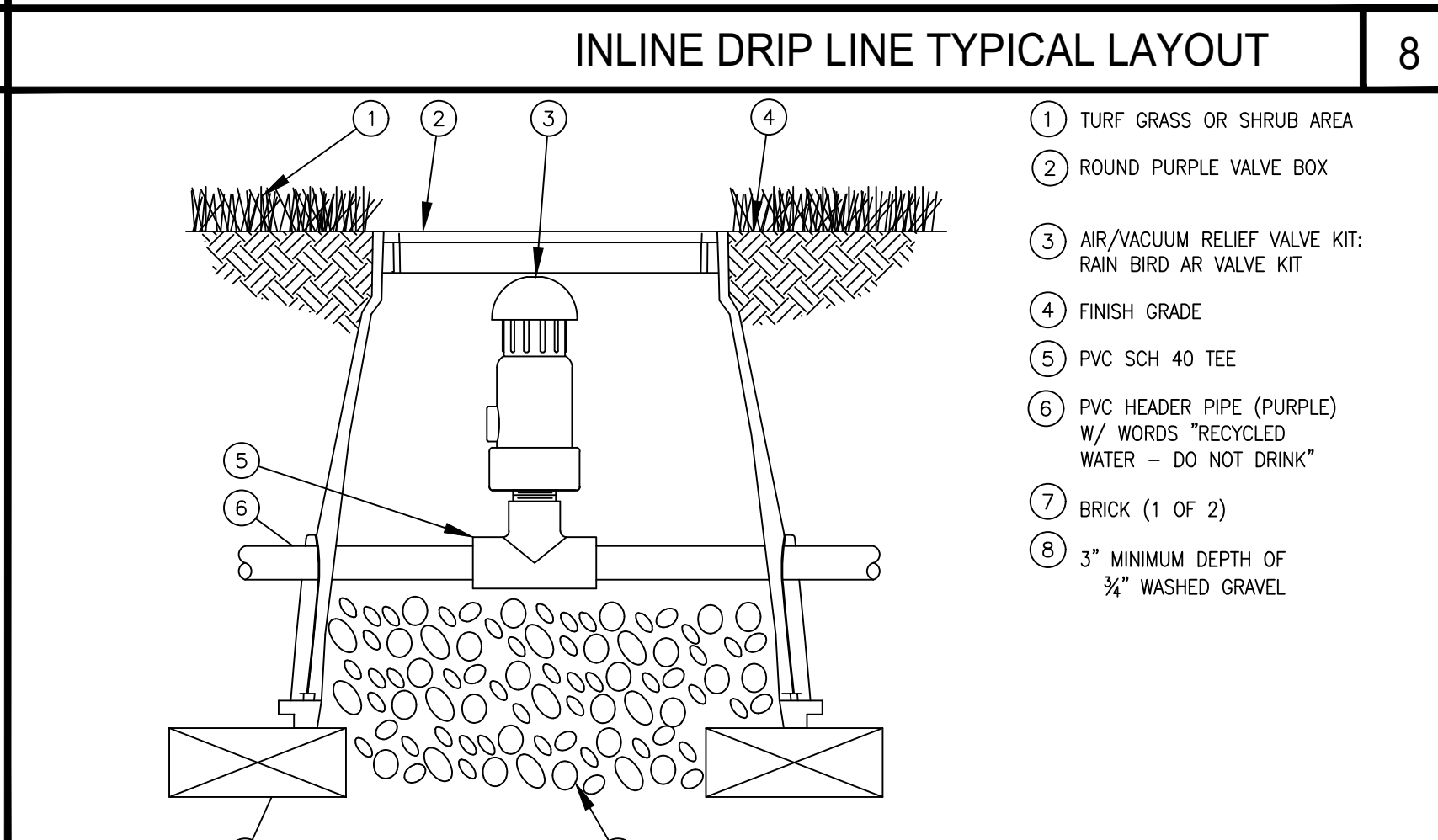

**DRIP AIR/VACUUM RELIEF** | 9

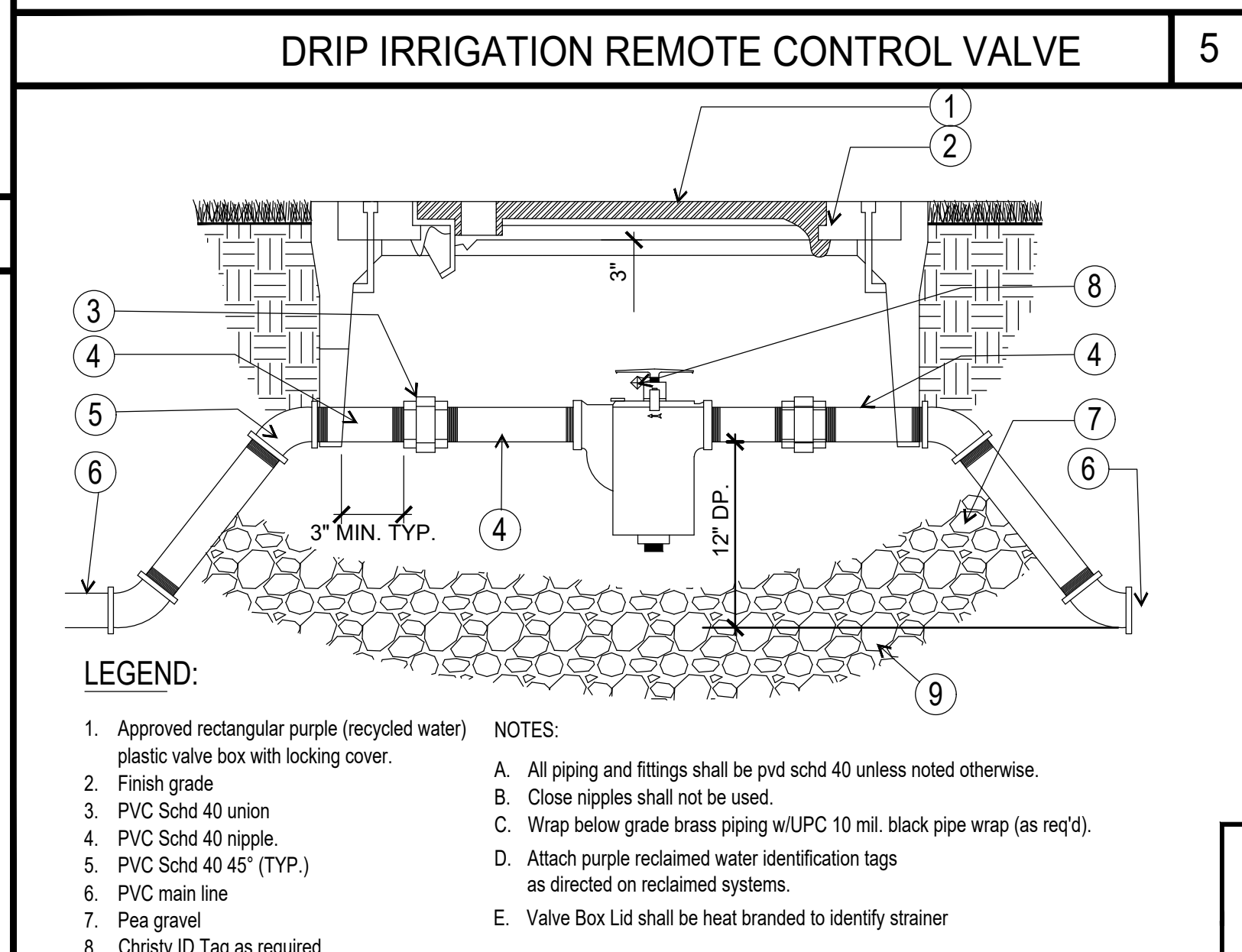

**BASKET STRAINER** | 6

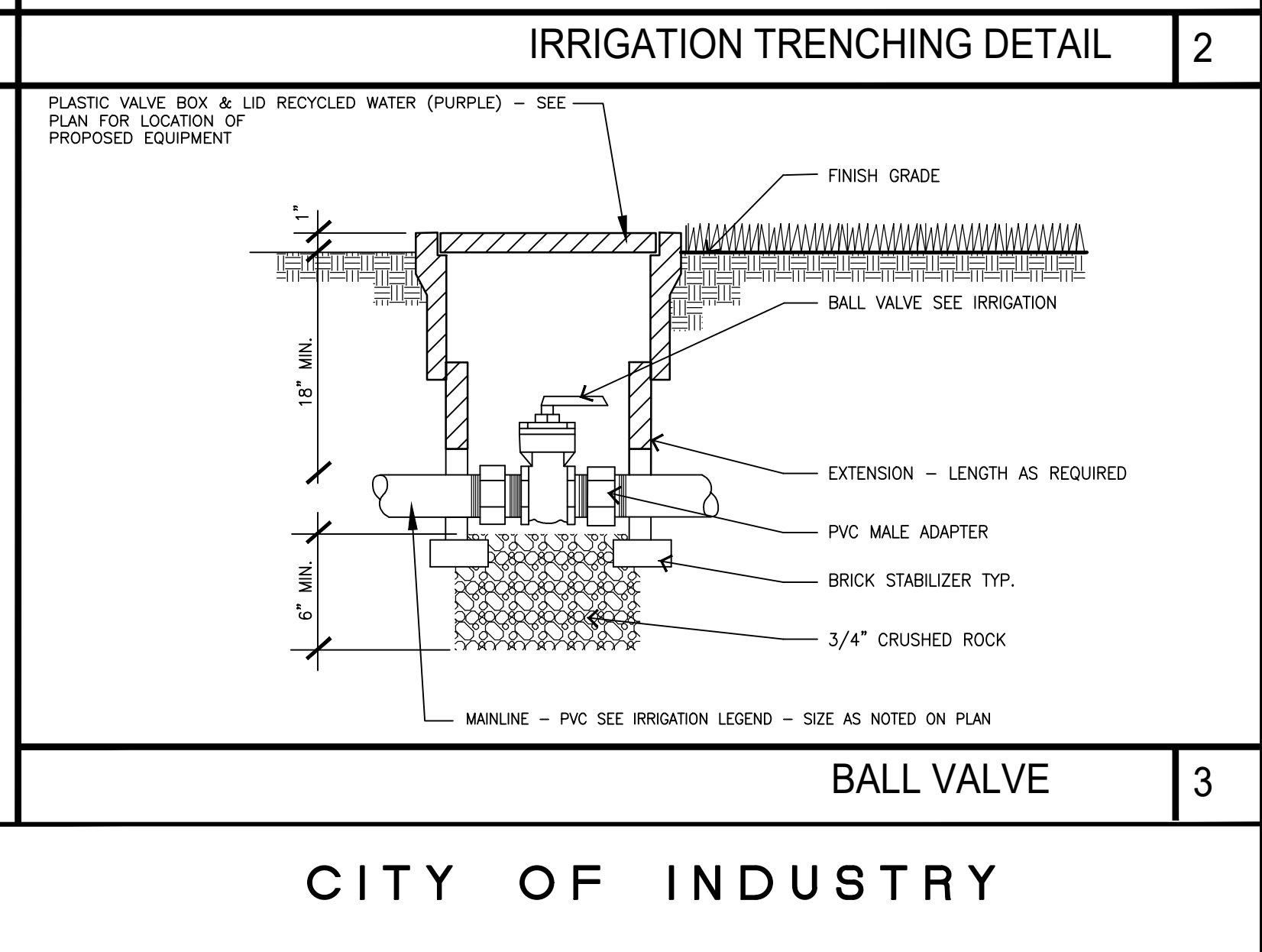

**BALL VALVE** | 3

NO.	DATE	REVISIONS	CK. BY

**CITY OF INDUSTRY**  
 INCORPORATED JUNE 18, 1957  
 P.O. Box 3366, City of Industry, California 91744  
 Administrative Offices: 15625 Mayor Dave Way (626) 333-2211

Prepared by: **Environs** inc  
 LANDSCAPE ARCHITECTURE  
 Creating Sustainable & Water Conserving Solutions  
 801 El Berrero • San Clemente, CA 92672  
 PH. (949) 636-4663

DESIGN BY: BKF DRAWN BY: BKF

APPROVED BY: \_\_\_\_\_ DATE: \_\_\_\_\_  
 CLEMENT N. CALVILLO, PE, REG 27743 DEPUTY CITY ENGINEER

**CITY OF INDUSTRY**

**SAN JOSE AVENUE RECONSTRUCTION FROM CHARLIE RD. TO NOGALES STREET**

**LANDSCAPE DETAILS**

DESIGNED BY: \_\_\_\_\_ CHECKED BY: \_\_\_\_\_  
 DRAFTED BY: \_\_\_\_\_ DATE: APRIL 12, 2022

JOB NO. CITY - MP 08-09 SHT. 11 OF 14

CONTRACT DRAWING OF

# LANDSCAPE CONSTRUCTION

1. SCOPE  
THE WORK OF THIS SECTION INCLUDES ALL LABOR, MATERIALS AND EQUIPMENT REQUIRED TO COMPLETE WORK INDICATED ON THE DRAWINGS. THE WORK SHALL BE PERFORMED IN ACCORDANCE WITH THE BEST STANDARDS OF PRACTICE RELATING TO THE VARIOUS TRADES AND UNDER THE CONTINUOUS SUPERVISION OF A COMPETENT FOREMAN, CAPABLE OF INTERPRETING THE DRAWINGS AND THESE SPECIFICATIONS. THE WORK INCLUDED IN THIS SECTION IS AS FOLLOWS: FINISH GRADING FOR PLANTING; SOIL PREPARATION; FERTILIZATION; PLANTING, INCLUDING LAWN MAINTENANCE; INSPECTION AND CERTIFICATIONS; GUARANTEES; CLEAN-UP; STAKING, GUYING AND ESPALIERING; MISCELLANEOUS ALLOWANCES.
2. APPROVALS  
A. ALL SPRINKLER WORK SHALL BE INSPECTED AND APPROVED PRIOR TO THE START OF ANY WORK.  
B. PRIOR TO EXCAVATION FOR PLANTING OR PLACING OF STAKES, LOCATE ALL UTILITIES, ELECTRIC CABLES, CONDUITS, SPRINKLER LINES, HEADS, VALVES AND VALVE CONTROL WIRES, AND ALL UTILITY LINES SO THAT PROPER PRECAUTIONS MAY BE TAKEN NOT TO DAMAGE SUCH IMPROVEMENTS. IN THE EVENT OF A CONFLICT BETWEEN SUCH LINES AND PLANT LOCATIONS, PROMPTLY NOTIFY LANDSCAPE ARCHITECT (L.A.) WHO SHALL ARRANGE FOR RELOCATION FOR ONE OR THE OTHER. FAILURE TO FOLLOW THIS PROCEDURE PLACES UPON CONTRACTOR THE RESPONSIBILITY FOR, AT HIS OWN EXPENSE, MAKING ANY AND ALL REPAIRS FOR DAMAGES RESULTING FROM WORK HEREUNDER.
3. QUANTITIES AND TYPES  
PLANT MATERIALS SHALL BE FURNISHED IN THE QUANTITIES AND/OR SPACING AS SHOWN OR NOTED FOR EACH LOCATION, AND SHALL BE OF THE SPECIES, KINDS, SIZES, ETC., AS SYMBOLIZED AND/OR DESCRIBED IN THE "PLANT MATERIAL LEGEND", AS INDICATED ON THE DRAWINGS. THE L.A. HAS PREPARED THIS LIST ONLY AS A CONVENIENCE TO CONTRACTOR AND ASSUMES NO RESPONSIBILITY FOR ITS ACCURACY. THE LANDSCAPE CONTRACTOR IS TO VERIFY ALL SIZES AND QUANTITIES.
4. VERIFICATION OF DIMENSIONS AND QUANTITIES  
DIMENSIONS ARE APPROXIMATE. BEFORE PROCEEDING WITH ANY WORK, CONTRACTOR SHALL VERIFY ALL DIMENSIONS AND QUANTITIES AND SHALL IMMEDIATELY INFORM L.A. AND OWNER OF ANY DISCREPANCIES BETWEEN THE DRAWINGS AND/OR SPECIFICATIONS AND ACTUAL CONDITIONS. NO WORK SHALL BE DONE IN ANY AREA WHERE THERE IS SUCH A DISCREPANCY UNTIL APPROVAL FOR SAME HAS BEEN GIVEN BY L.A. AND OWNER.
5. INSPECTION  
A. ALL INSPECTIONS SHALL BE MADE BY L.A. AND OWNER. CONTRACTOR SHALL REQUEST INSPECTION AT LEAST TWO (2) DAYS IN ADVANCE OF THE TIME INSPECTION IS REQUIRED.  
B. INSPECTION WILL BE REQUIRED FOR THE FOLLOWING PARTS OF THE WORK:  
(1) DURING FINISH GRADING AND SOIL PREPARATION  
(2) PLANTS, AFTER DELIVERY TO SITE AND PRIOR TO PLANTING.  
(3) WHEN VINES, SHRUBS AND TREES ARE SPOTTED FOR PLANTING, BUT PLANTING HOLES ARE NOT EXCAVATED.  
(4) SPECIMEN TREES AT SOURCE, BEFORE DELIVERY.  
(5) LAWN AREAS PRIOR TO PLANTING.  
(6) PLANTING AREAS PRIOR TO PLANTING.  
(7) ALL LANDSCAPE CONSTRUCTION ITEMS, PRIOR TO THE START OF THE CALENDAR DAY MAINTENANCE PERIOD ("FINAL INSPECTION").  
(8) AT COMPLETION OF CALENDAR DAY MAINTENANCE PERIOD ("FINAL MAINTENANCE INSPECTION").  
(9) INSPECTION REPORTS SHALL BE MADE FOR EACH INSPECTION BY THE L.A. AND ONE COPY SHALL BE SUBMITTED TO OWNER AND CONTRACTOR.
6. CERTIFICATION  
PRIOR TO JOB ACCEPTANCE WRITTEN CERTIFICATIONS SHALL BE SUBMITTED TO THE L.A. FOR THE FOLLOWING:  
A. QUANTITY AND QUALITY OF COMMERCIAL FERTILIZER AND ORGANIC FERTILIZER.  
B. QUANTITY AND QUALITY OF ALL SOIL AMMENDMENTS CALLED FOR BY PLANS AND SPECIFICATIONS.
7. MATERIALS  
PLANT MATERIALS INDICATED ON THE DRAWINGS AND HEREIN SPECIFIED SHALL CONFORM TO THE FOLLOWING:  
A. NOMENCLATURE - PLANT NAMES INDICATED ON THE DRAWINGS CONFORM TO "STANDARD PLANT NAMES" ESTABLISHED BY THE AMERICAN JOINT COMMITTEE ON HORTICULTURE. EXCEPT FOR NAMES COVERED THEREIN, THE ESTABLISHED CUSTOM OF THE NURSERY IS FOLLOWED.  
B. CONDITION - PLANTS SHALL BE SYMMETRICAL, TYPICAL FOR VARIETY AND SPECIES, SOUND, HEALTHY, VIGOROUS, FREE FROM PLANT DISEASE, INSECT PESTS, OR THEIR EGGS, AND SHALL HAVE HEALTHY, NORMAL ROOT SYSTEMS, WELL FILLING THEIR CONTAINERS, BUT NOT TO THE POINT OF BEING ROOT BOUND. PLANTS SHALL NOT BE PRUNED PRIOR TO DELIVERY, EXCEPT AS AUTHORIZED BY L.A. OR HIS REPRESENTATIVE. IN NO CASE SHALL TREES BE TOPPED BEFORE DELIVERY.  
C. DIMENSIONS - THE HEIGHT AND SPREAD OF ALL PLANT MATERIAL SHALL BE MEASURED WITH BRANCHES IN THEIR NORMAL POSITION, AND SHALL BE AS INDICATED ON THE DRAWINGS. THE CALIPER OF ALL TREES SHALL BE MEASURED 4"-0" ABOVE THE SURFACE OF THE GROUND. WHERE CALIPER OR OTHER DIMENSIONS OF ANY PLANT MATERIALS ARE OMITTED FROM THE "PLANT LEGEND", IT SHALL BE UNDERSTOOD THAT THESE PLANT MATERIALS SHALL BE NORMAL STOCK FOR TYPE LISTED.  
D. INSPECTION - ALL PLANT MATERIALS MUST HAVE BEEN PREVIOUSLY INSPECTED AT THE NURSERY BY THE COUNTY HORTICULTURAL DEPARTMENT, AND SHALL BE SUBJECT TO THE INSPECTION AND APPROVAL OF THE L.A. BEFORE PLANTING.  
E. PLANT LIST - IS INDICATED ON DRAWINGS.  
F. SIZES OF PLANTS - SHALL BE AS STATED ON THE PLAN. CONTAINER STOCK (1- GALLON, 5- GALLON AND 15-GALLON), SHALL HAVE BEEN GROWN IN CONTAINERS FOR AT LEAST ONE (1) YEAR, BUT NOT OVER TWO YEARS.  
G. SUBSTITUTIONS - SUBSTITUTIONS FOR THE INDICATED PLANT MATERIALS WILL BE PERMITTED PROVIDED THE SUBSTITUTE MATERIALS ARE APPROVED IN ADVANCE BY THE L.A. AND THE SUBSTITUTIONS ARE MADE AT NO ADDITIONAL COST TO OWNER. EXCEPT FOR AUTHORIZED VARIATIONS, ALL SUBSTITUTE PLANT MATERIALS SHALL CONFORM TO THE REQUIREMENTS OF THESE SPECIFICATIONS. IF THE ACCEPTED SUBSTITUTE MATERIALS ARE OF A LESS VALUE THAN THOSE INDICATED OR SPECIFIED, THE CONTRACT PRICE WILL BE ADJUSTED IN ACCORDANCE WITH THE PROVISIONS OF THE CONTRACT.  
H. PLANTS NOT APPROVED - PLANTS NOT APPROVED ARE TO BE REMOVED FROM SITE IMMEDIATELY AND REPLACED WITH SUITABLE PLANTS. THE L.A. AND/OR OWNER RESERVES THE RIGHT TO REJECT ENTIRE LOTS OF PLANTS REPRESENTED BY DEFECTIVE SAMPLES.
8. FERTILIZERS AND SOIL CONDITIONERS  
SAMPLES OF ALL SOIL AMMENDMENTS, SOD AND PLANTS SHALL BE SUBMITTED FOR INSPECTION AND STORED ON THE SITE UNTIL FURNISHING OF MATERIALS IS COMPLETED. DELIVERY MAY BEGIN UPON APPROVAL OF SAMPLES OR AS DIRECTED BY L.A. AND THE OWNER.  
A. ORGANIC FERTILIZER SHALL BE PROCESSED SEWAGE SLUDGE WITH A MINIMUM CONTENT OF 1% NITROGEN AND 2% PHOSPHORIC ACID SIMILAR TO "NITROHUMUS". METHOD OF PROCESSING SHALL NOT DESTROY NORMAL BACTERIAL CONTENT.

- B. NITROGEN STABILIZED SAWDUST SHALL BE BULK, WITH THE FOLLOWING NITROGEN CONTENT BASED ON DRY WEIGHT:  
0.5% FOR REDWOOD SAWDUST  
0.7% FOR FIR SAWDUST  
1.0% FOR BARK OR PINE BARK OR MIXTURE  
SALINITY - THE SATURATION EXTRACT CONDUCTIVITY SHALL NOT EXCEED 3.5 MILLIMHOS /CM AT 25
- C. COMMERCIAL FERTILIZER SHALL BE DELIVERED IN SACKS WITH MANUFACTURER'S LABEL SHOWING WEIGHT AND ANALYSIS ATTACHED TO EACH SACK.
9. STAKING MATERIALS  
A. TREE-STAKING SHALL BE AS PER PLAN.  
B. TIES FOR HOLDING TREES SHALL BE AS PER PLAN.
10. GRADING AND SOIL PREPARATION  
A. CONTRACTOR IS TO FINISH GRADE TO WITHIN 1/10TH OF A FOOT OR 1" BELOW PAVING WHERE PAVING EXISTS.  
B. MOISTURE CONTENT - THE SOILS SHALL NOT BE WORKED WHEN THE MOISTURE CONTENT IS SO GREAT THAT EXCESSIVE COMPACTION WILL OCCUR; AND NOT WHEN IT IS SO DRY THAT DUST WILL FORM IN THE AIR OR THAT CLOUDS WILL NOT BREAK READILY. WATER SHALL BE APPLIED IF NECESSARY TO PROVIDE IDEAL MOISTURE CONTENT FOR TILLING AND FOR PLANTING.  
C. PRELIMINARY GRADING - PRELIMINARY GRADING SHALL BE DONE IN SUCH A MANNER AS TO ANTICIPATE THE FINISH GRADING. EXCESS SOILS SHALL BE REMOVED OR REDISTRIBUTED BEFORE APPLICATION OF FERTILIZER AND MULCH. WHERE SOIL IS TO BE REPLACED BY PLANTS AND MULCH, ALLOWANCE SHALL BE MADE SO THAT WHEN FINISH GRADING HAS BEGUN, THERE SHALL BE NO DEFICIENCY IN THE SPECIFIED DEPTH OF MULCHED PLANTING BEDS.  
D. WEEDING - BEFORE AND DURING PRELIMINARY AND FINISH GRADING, ALL WEEDS AND GRASSES SHALL BE DUG OUT BY THE ROOTS AND DISPOSED OF OFF SITE (EXCEPT THOSE WEEDS AND GRASSES NOT OF THE PERENNIAL TYPE, LESS THAN 2-1/2" HIGH AND NOT BEARING SEEDS, WHICH MAY BE TURNED UNDER). OATS MORE THAN 2-1/2" HIGH AND NOT BEARING SEEDS MAY BE TURNED UNDER. PERENNIAL WEEDS AND GRASSES TO BE REMOVED INCLUDE, BUT ARE NOT LIMITED TO, THE FOLLOWING: NUT GRASS, PUNCTURE VINE, DALLAS GRASS, MUSTARD PLANT, ST. AUGUSTINE, ALFALFA, JOHNSON GRASS, WIRE WEED, MORNING GLORY.  
E. ALL PLANTING AREAS SHALL BE SCARIFIED TO A DEPTH OF 12 INCHES BELOW GRADE WITH THE SPACING OF THE RIPPER TEETH NO GREATER THAN 12 INCHES ON CENTER PRIOR TO PLACING CONDITIONERS AND FERTILIZERS. ALL ROCK AND DEBRIS MORE THAN 2" IN DIAMETER SHALL BE REMOVED FROM THE SITE.  
F. TRENCHES - IF IRRIGATION SYSTEM IS INSTALLED AFTER GRADING AND FERTILIZING IS COMPLETED, THE UPPER PORTION OF THE BACKFILL SHALL BE RETILLED AND FERTILIZED TO THE DEPTH SPECIFIED FOR THE AREA REQUIRED, TO CONFORM TO THE SPECIFICATIONS.
11. SOIL CONDITIONERS (TO BE REVISED PER SOILS REPORT)  
A. TURF, GROUND COVER & SHRUB AREA: WITH THE EXCEPTION OF THE SLOPES THE AREAS TO BE LANDSCAPED SHOULD BE CROSS-RIPPED OR OTHERWISE TILLED TO A DEPTH OF 9-12 INCHES. FOR TURF AND GROUND COVER PLANTING, THE FOLLOWING AMENDMENT SHOULD BE UNIFORM BY BROADCAST AND THOROUGHLY INCORPORATED TO A DEPTH OF 6 INCHES BY MEANS OF ROTOTILLER OR EQUAL. AMT PER 1,000 SQUARE FEET 6 CU. YDS. NITROGEN STABILIZED ORGANIC AMMENDMENT DERIVED FROM REDWOOD SAWDUST, FIR SAWDUST OR CEDAR SAWDUST 12 LBS. 16-20-0 AMMONIUM PHOSPHATE (TO BE INCORPORATED TO THE 6" DEPTH FOLLOWING LEACHING). FOLLOWING AMENDING AND PRIOR TO PLANTING, INCLUDING TREES AND SHRUBS, LEACHING IRRIGATIONS SHOULD BE MADE IN A MANNER THAT WILL PASS THE MINIMUM OF 12 INCHES OF WATER THROUGH THE SURFACE SOIL ZONE. WHEN THE LEACHING PROGRAM HAS BEEN COMPLETED, ADDITIONAL SAMPLES SHOULD BE COLLECTED FOR SOIL FERTILITY ANALYSES ONLY.  
B. SLOPES:  
300 LBS./ACRE 16-20-0 AMMONIUM PHOSPHATE  
300 LBS./ACRE UREA FORMALDEHYDE  
MULCH SILVA FIBER PLUS, 2,000 LB./ACRE  
BINDING AGENT (PER CONTRACTOR'S ACCEPTED PROCEDURE)  
WHILE THE UREA FORMALDEHYDE IS A SLOW-RELEASE NITROGEN FERTILIZER, IT WILL PROBABLY BE NECESSARY TO MAKE DRY SUPPLEMENTAL FERTILIZER APPLICATIONS, PARTICULARLY DURING THE ESTABLISHMENT PERIOD. IF THIS IS THE CASE, THE 16-20-0 SHOULD BE UNIFORMLY BROADCAST OVER DRY SLOPE AREAS AT THE RATE OF 6 POUNDS PER 1,000 SQUARE FEET AND FOLLOWED WITH A NORMAL IRRIGATION AT EACH FERTILIZING PERIOD.  
C. PLANTING PITS - TREE & SHRUB, ALL AREAS INCLUDING SLOPES: PLANTING PITS SHALL BE EXCAVATED TWICE THE DIAMETER AND TWICE THE DEPTH OF THE ROOTBALL. BACKFILL SHALL THEN BE ADDED AS SPECIFIED.  
(1) A CHEMICALLY SUITABLE SANDY TEXTURED IMPORT SOIL MEETING THE FOLLOWING SPECIFICATIONS SHOULD BE USED FOR BACKFILL TO THE DEPTH OF THE ROOTBALL. FOR TREES, SHRUBS AND VINES (OTHER THAN AZALEAS, FERNS AND PALMS).  
SILT PLUS CLAY CONTENT OF THE IMPORT SOIL SHALL NOT EXCEED 30 % BY WEIGHT WITH A MINIMUM PERCENTAGE PASSING THE 2.0 MILLIMETER SIEVE. THE SOIL'S WATER ABSORPTION RATIO (SAR) SHALL NOT EXCEED 6 AND THE ELECTRICAL CONDUCTIVITY (ECe) SHALL NOT EXCEED 3.0 MILLIMHOS PER CENTIMETER AT 25 DEGREES CENTIGRADE. THE BORON CONTENT SHALL BE NO GREATER THAN 1 PPM AS MEASURED ON THE SATURATION EXTRACT. IN ORDER TO INSURE CONFORMANCE, SAMPLES OF THE IMPORT SOIL SHOULD BE SUBMITTED TO THE LABORATORY FOR ANALYSIS PRIOR TO AND FOLLOWING BACKFILLING. THE BACKFILL MIX FOR USE AROUND THE ROOTBALL SHOULD BE PREPARED AS FOLLOWS:  
6 PARTS BY VOLUME SANDY-TEXTURED IMPORT SOIL  
4 PARTS BY VOLUME NITROGEN STABILIZED WOOD RESIDUAL  
1 LB. 16-20-0 PER CU. YD. OF MIX  
2 LBS. IRON SULFATE PER CU. YD. OF MIX  
THE ABOVE MATERIALS SHOULD BE THOROUGHLY BLENDED PRIOR TO USE FOR BACKFILL PURPOSES. ALSO, THE IRON SULFATE SHOULD NOT CONTACT CEMENT SURFACES SINCE SEVERE STAINING COULD OCCUR. APPLY PLANTING TABLETS AS PER MANUFACTURER'S RECOMMENDATIONS. IF THE 16-20-0 IS INCORPORATED PRELIMINARY AS RECOMMENDED, THE POST PLANT MAINTENANCE CAN CONSIST PRIMARILY OF A NITROGEN-ONLY FERTILIZER PROGRAM. BEGINNING APPROXIMATELY 30 DAYS AFTER PLANTING, AMMONIUM SULFATE SHOULD BE APPLIED AT THE RATE OF 5 LBS./1,000 S.F. OR AMMONIUM NITRATE AT THE RATE OF 3 LBS./1,000 S.F. ON A MONTHLY BASIS. HOWEVER, IN ORDER TO ENSURE CONTINUING ADEQUATE SOIL PHOSPHORUS AND POTASSIUM NUTRITION, BEST FERTILIZER COMPANY'S 16-6-8 OR EQUAL SHOULD BE SUBSTITUTED FOR THE NITROGEN MATERIALS TWICE A YEAR AT THE RATE OF 6 POUNDS PER 1,000 SQUARE FEET. ALSO, WHEN PLANTS HAVE BECOME WELL ESTABLISHED, THE FREQUENCY OF FERTILIZER APPLICATIONS CAN BE DECREASED.  
D. THE PREPARED SOIL SHALL BE UNIFORMLY BLENDED IN AN AREA ADJACENT TO THE PLANTING WORK AND SHALL BE ACCURATELY PROPORTIONED USING A SUITABLE MEASURING CONTAINER. UNUSED EXCAVATED SOIL SHALL BE REMOVED FROM SITE. PROTECT THE MIX FROM WATER UNTIL IT HAS BEEN PLACED IN BACKFILL AROUND PLANTS.
12. FINISH GRADING  
WHEN PRELIMINARY GRADING, INCLUDING WEEDING AND FERTILIZING, HAS BEEN COMPLETED AND THE SOIL HAS DRIED SUFFICIENTLY TO BE READILY WORKED, ALL LAWN AND PLANTING AREAS SHALL BE GRADED TO THE ELEVATIONS INDICATED ON THE DRAWINGS. GRADES NOT OTHERWISE INDICATED SHALL BE UNIFORM LEVELS OR SLOPES BETWEEN POINTS WHERE ELEVATIONS ARE GIVEN. MINOR ADJUSTMENTS OF FINISH GRADES SHALL BE MADE AT THE DIRECTION OF THE L.A. IF REQUIRED.  
FINISH GRADE SHALL BE A SMOOTH, EVEN AND UNIFORM PLANE WITHOUT ABRUPT CHANGE OF SURFACE. SOIL AREAS ADJACENT TO BUILDINGS TO ALLOW A NATURAL RUN-OFF OF WATER, AND SURFACE DRAINAGE SHALL BE DIRECTED AS INDICATED ON THE DRAWINGS BY REMODELING SURFACES TO FACILITATE THE NATURAL "RUN-OFF" OF WATER. LOW SPOTS AND POCKETS SHALL BE ONE (1) FOOT BELOW GRADE OF ADJACENT PAVEMENT OF ANY KIND. GRADING SHALL BE DONE WHEN SOIL IS AT OPTIMUM MOISTURE CONTENT FOR WORKING.
13. METHOD OF PLANTING AND WORK PROCEDURE  
A. NO PLANTING SHALL BE DONE UNTIL ALL OPERATIONS IN CONJUNCTION WITH THE INSTALLATION OF THE IRRIGATION SYSTEM HAVE BEEN COMPLETED, FINAL GRADES HAVE BEEN ESTABLISHED, THE PLANTING AREAS HAVE BEEN PROPERLY GRADED AND PREPARED AS SPECIFIED, AND THE WORK APPROVED BY THE L.A.  
B. THE RELATIVE POSITION OF ALL TREES AND PLANTS IS SUBJECT TO APPROVAL BY L.A. AND OWNER, AND THEY SHALL, IF NECESSARY, BE RELOCATED AS DIRECTED AS PART OF THE CONTRACT.  
C. ALL PLANTS SHALL BE REMOVED FROM THEIR CONTAINER AND SET SO THAT, WHEN SETTLED, THEY BEAR THE SAME RELATION TO THE REQUIRED GRADE THAT THEY BEARE TO THE NATURAL GRADE BEFORE BEING TRANSPLANTED. EACH PLANT SHALL BE PLANTED IN THE CENTER OF THE PIT AND BACKFILLED UNLESS OTHERWISE SPECIFIED, WITH THE PREPARED SOIL. NO SOIL IN MUDDY CONDITION SHALL BE USED FOR BACKFILLING. NO FILLING WILL BE PERMITTED AROUND TRUNKS OR STEMS. ALL BROKEN OR FRAVED ROOTS SHALL BE PROPERLY CUT OFF.  
D. LA. AND/OR OWNER SHALL SUPERVISE THE PLACING AND PLANTING OF ALL PLANTS.  
E. IN THE EVENT THAT UNDERGROUND CONSTRUCTION WORK OR OBSTRUCTIONS ARE ENCOUNTERED IN THE PLANTING OPERATION, ALTERNATE LOCATIONS FOR PLANT MATERIAL WILL BE SELECTED BY L.A. AND OWNER; OPERATION WILL BE DONE AT NO EXTRA COST TO OWNER.
14. PLANTING OF TREES  
A. POSITION PLANTS IN PLANT LOCATIONS INDICATED ON DRAWINGS AND SECURE APPROVAL BEFORE EXCAVATING PITS, MAKING NECESSARY ADJUSTMENTS AS INDICATED.  
B. ALL PITS FOR TREES SHALL BE DUG SQUARE WITH BOTTOMS LEVEL, THE LENGTH OF SIDES AND DEPTH EQUAL TO TWO TIMES THE DIAMETER OF THE TREE BALL. COMPACTED SOILS AT SIDES AND BOTTOMS SHALL BE LOOSENEED BY SCARIFYING OR OTHER APPROVED METHOD. PITS SHALL BE BACKFILLED WITH "PREPARED SOIL" TO THE REQUIRED GRADE, AND THE BALANCE OF THE PIT FILLED WITH "PREPARED SOIL" THOROUGHLY SETTLED BY WATER APPLICATION.  
C. SET PLANTS IN CENTER OF PIT, IN A VERTICAL POSITION, SO THAT CROWN OF BALL WILL BE LEVEL WITH FINISH GRADE AFTER ALLOWING FOR WATERING AND SETTLING AND SHALL BEAR THE SAME RELATIONSHIP TO THE FINISH GRADE THAT IT DID TO THE SOIL SURFACE IN THE CONTAINER.  
D. PREPARE DEPRESSED WATER BASIN AS WIDE AS PLANT BALLS AT EACH PLANT. WATER THOROUGHLY, BACKFILLING ANY VOIDS WITH ADDITIONAL PREPARED PLANTING MIX.
15. PLANTING VINES, SHRUBS AND GROUNDCOVERS  
A. VINES AND SHRUBS SHALL BE PLANTED IN PITS AT LEAST 18" GREATER IN DIAMETER THAN THEIR BALL OF EARTH AND AT LEAST 12" BELOW THE BOTTOM OF THE BALL. COMPACTED SOIL AT BOTTOM OF PIT SHALL BE LOOSENEED AND THE PIT FILLED WITH "PREPARED SOIL" TO THE BOTTOM OF THE BALL. WHEN THE PLANT HAS BEEN PROPERLY SET, THE PIT SHALL BE FILLED TO THE REQUIRED GRADE WITH "PREPARED SOIL" AND THOROUGHLY SETTLED BY TAPING AND WATERING. ALL VINES SHALL BE REMOVED FROM STAKES, UNTIED, AND SECURELY FASTENED IN AN APPROVED MANNER TO THE WALL, FENCE OR OTHER SURFACE NEXT TO WHICH THEY ARE PLANTED.  
B. PREPARE A DEPRESSED WATER BASIN AS WIDE AS PLANT BALLS AT EACH PLANT. WATER THOROUGHLY, BACKFILLING ANY VOIDS WITH ADDITIONAL PREPARED PLANTING MIX.  
C. GROUND COVERS  
(1) PITS FOR FLAT SIZED PLANTS TO BE AT LEAST 6"x6". GROUND COVER AREAS SHALL BE MOISTENED PRIOR TO PLANTING. NO FLAT PLANTS SHALL BE PLANTED IN DRY SOIL.  
(2) SET PLANTS IN CENTER OF PITS THAT CROWN OFFPLANT WILL BE LEVEL WITH FINISHED GRADE AFTER SETTLING OF SOIL, THEN BACKFILL AND WATER.  
(3) FLATTED PLANTS SHALL BE WELL-ROOTED WITH RUNNERS AT LEAST 4" BUT NOT MORE THAN 6" IN LENGTH.
16. TREES AND VINES OCCURRING IN LAWN  
TREES AND VINES OCCURRING IN LAWN SHALL BE PLANTED BEFORE FINAL PREPARATION OF THOSE AREAS.
17. CARE OF PLANTS BEFORE AND DURING PLANTING  
PLANTS SHALL NOT BE ALLOWED TO DRY OUT BEFORE OR WHILE BEING PLANTED. KEEP EXPOSED ROOTS MOIST BY MEANS OF WET SAWDUST, PEAT MOSS OR BURLAP AT ALL TIMES DURING PLANTING OPERATIONS. DO NOT EXPOSE ROOTS TO THE AIR EXCEPT WHILE BEING PLACED IN THE GROUND. WILTED PLANTS, WHETHER IN PLACE OR NOT, WILL NOT BE ACCEPTED AND SHALL BE REPLACED AT THE CONTRACTOR'S EXPENSE.
18. WATERING BASINS  
A. CONSTRUCT A FIRMLY COMPACTED MOUND OF SOIL AROUND EACH TREE AND PLANT TO FORM A WATERING BASIN AT THE EDGE OF AND FOLLOWING THE SHAPE OF THE PLANTING PIT AREA. MOUNDS OR TREES AND FOR VINES FROM 5-GALLON OR LARGER CONTAINERS, SHALL BE AT LEAST 4" HIGH. MOUNDS FOR ALL OTHER TREES, VINES OR PLANTS NOT OTHERWISE SPECIFIED SHALL BE AT LEAST 2" HIGH. EXCAVATED EARTH, IF CAPABLE OF RETAINING WATER, MAY BE USED. ANY SETTLEMENT WITHIN THE BASIN RETAINING WATER SHALL BE REFILLED TO THE REQUIRED GRADE WITH PREPARED SOIL, AND ADDITIONAL NITROGEN STABILIZED SAWDUST WORKED INTO THE SURFACE AS REQUIRED TO RESTORE THE MULCHED CONDITION.  
B. AT THE END OF THE DAY MAINTENANCE PERIOD ALL WATERING BASINS IN LAWN AREAS SHALL BE LEVELED TO FINISH GRADE AND THE AREA SHALL BE SODDED WITH THE SPECIFIC SOD.  
19. SODDED LAWN  
A. CULTIVATE ALL LAWN AREAS TO A DEPTH OF 8". ROCKS AND DEBRIS LARGER THAN 1" IN DIAMETER WHICH ARE BROUGHT TO THE SURFACE BY CULTIVATION SHALL BE REMOVED FROM THE SITE. IF CULTIVATION DOES NOT BREAK LUMPS, A SPIKE TOOTH HARROW SHALL BE PULLED BEHIND A MECHANICAL SEEDER OR TRACTOR.  
B. AREAS TO BE PLANTED IN LAWN SHALL BE FINISHED SMOOTH TO PRESENT A NEAT AND UNIFORM GRADE PRIOR TO INSTALLATION OF SOD. THE LAWN BED SHALL BE INSPECTED BY THE L.A. TO DETERMINE SUITABILITY FOR PLANTING PRIOR TO SODDING. CONTRACTOR SHALL OBTAIN SUCH APPROVAL BEFORE SODDING.  
C. ALL SODDED AREAS SHALL BE THOROUGHLY WATERED. LAWNS ARE TO BE KEPT CONTINUOUSLY MOIST BY WATERING AS OFTEN AS REQUIRED.  
D. ANY LAWN AREAS THAT DO NOT SHOW A PROMPT CATCH OF GRASS SHALL BE RE-SODDED AT TEN DAY INTERVALS UNTIL AN ACCEPTABLE STAND OF GRASS IS ASSURED.
20. WATERING  
A. IMMEDIATELY AFTER PLANTING, WATER SHALL BE APPLIED TO EACH TREE BY MEANS OF A HOSE. THE WATER SHALL BE APPLIED IN A MODERATE STREAM IN THE PLANTING HOLES UNTIL THE MATERIAL ABOUT THE ROOTS IS COMPLETELY SATURATED FROM THE BOTTOM OF THE HOLE TO THE TOP OF THE GROUND.  
B. PLANTS WHICH CANNOT BE WATERED EFFICIENTLY WITH THE EXISTING WATER SYSTEM SHALL BE WATERED BY MEANS OF A HOSE.  
C. APPLY WATER IN SUFFICIENT QUANTITIES, AND AS OFTEN AS SEASONAL CONDITIONS REQUIRE, TO KEEP THE GROUND WET AT ALL TIMES, WELL BELOW THE ROOT SYSTEM OF GRASS AND PLANTING. CARE IS TO BE TAKEN IN WATERING SLOPES SO AS NOT TO CAUSE EROSION DAMAGE.  
D. FOLLOWING THE PLANTING OF GROUND COVER PLANTS FURNISHED IN FLATS, EACH PLANT SHALL BE IMMEDIATELY AND THOROUGHLY WATERED BY MEANS OF A HOSE WITH A SLOW RUNNING STREAM OF WATER.
21. TREE STAKING  
A. STAKE ALL NON-GUYED TREES AT TIME OF PLANTING BY PLACING STAKE IN THE PREPARED HOLE AND DRIVING IT 18" INTO SOLID GROUND. PLANT THE TREE AS CLOSE TO THE STAKE AS POSSIBLE WITHOUT CROWDING THE ROOTS. FASTEN THE TREE TO THE UPPER END OF STAKE IN AT LEAST THREE PLACES USING "CINCH TIES". (SEE DRAWINGS)

- B. TREES 36" BOX SIZE OR LARGER, SHALL BE IMMEDIATELY GUYED AFTER PLANTING WITH NOT LESS THAN THREE GUYS PER TREE, OR AS DIRECTED BY THE L.A.  
(1) PROTECT BARK OF TREE BY COVERING WIRE WITH GREEN 1/2" DIAMETER RUBBER HOSE.  
(2) GUYS TO BE ANCHORED BY 2"x2"x2" REDWOOD DRIVEN FLUSH WITH FINISH GRADE OR 1"x2" GALVANIZED PIPE IN ROCKY AREAS.  
(3) GUY WIRES SHALL BE #12 GA. GALVANIZED WIRE. MARK GUYS WITH 3'-0" LONG 1/2" DIA. WHITE PVC PIPE.  
(4) GUY LINES ARE TO BE TIGHTENED TO FIRM TENSION.
22. ESPALIERING OF VINES  
ALL TRELISES AND STAKES ARE TO BE REMOVED FROM PLANTS AND THE PLANTS SHALL BE FASTENED AND TRAINED AGAINST FENCES OR WALLS AS DIRECTED BY THE L.A.
23. CERTIFICATIONS  
IN ADDITION TO ANY OTHER CERTIFICATES SPECIFIED, CONTRACTOR SHALL FURNISH A CERTIFICATE WITH EACH DELIVERY OF BULK MATERIAL, STATING THE SOURCE, QUANTITY AND TYPE OF MATERIAL AND THAT THE MATERIAL CONFORMS TO THE SPECIFICATION REQUIREMENTS. FOR BULK DELIVERED ORGANIC FERTILIZER, THE CERTIFICATE SHALL ALSO STATE THE VOLUME, NET WEIGHT, PERCENT OF NITROGEN AND PERCENT OF PHOSPHORIC ACID. FOR EACH FERTILIZER AND SOIL CONDITIONER, IN CONTAINERS, A SIMILAR CERTIFICATE OR INVOICE SHALL BE FURNISHED STATING TOTAL QUANTITIES BY WEIGHT AND VOLUME FOR EACH MATERIAL. THESE CERTIFICATES SHALL BE SUBMITTED TO THE L.A. AND OWNER PRIOR TO THE STRART OF THE MAINTENANCE PERIOD.
24. PROTECTION  
CONTRACTOR SHALL CAREFULLY AND CONTINUOUSLY PROTECT ALL AREAS INCLUDED IN THE CONTRACT, INCLUDING PLANT MATERIALS, FENCES, SUPPORTS, ETC., UNTIL FINAL ACCEPTANCE OF THE WORK BY THE L.A. AND OWNER.
25. MAINTENANCE  
A. CONTRACTOR SHALL MAINTAIN A SUFFICIENT NUMBER OF MEN AND ADEQUATE EQUIPMENT TO PERFORM THE WORK HERE IN SPECIFIED. PLANT MAINTENANCE WORK SHALL CONSIST OF APPLYING WATER, WEEDING, CARING FOR PLANTS, INCLUDING GROUNDCOVERS, SHRUBS AND TREES, EDGING, AERATING AND MOWING OF LAWNS, FERTILIZING AND CONTROL OF PESTS AND DISEASES.  
B. DAMAGE TO ANY PLANTED AREA SHALL BE REPAIRED IMMEDIATELY. DEPRESSIONS CAUSED BY VEHICLES OR FOOT TRAFFIC SHALL BE FILLED WITH TOPSOIL, LEVELED AND REPLANTED. EXTERMINATE GOPHERS AND MOLES, AND REPAIR DAMAGE.  
C. THE ENTIRE PROJECT SHALL BE MAINTAINED FOR A PERIOD OF DAYS COMMENCING FROM THE TIME ALL ITEMS OF WORK HAVE BEEN COMPLETED TO THE SATISFACTION OF L.A. AND OWNER.  
D. THE PROJECT SHALL BE CARED FOR IN A NEAT, CLEAN CONDITION AT ALL TIMES TO THE SATISFACTION OF OWNER AND L.A.
26. LAWN MAINTENANCE  
A. WATERING - WATER EVERY DAY ONCE PER DAY FOR TWO WEEKS AND THEREAFTER GRADUALLY REDUCE FREQUENCY OF WATERING TO THREE TIMES PER WEEK. CONTRACTOR SHALL CONTINUE TO MAINTAIN THE LAWN UNTIL FINAL ACCEPTANCE BY THE L.A. AND OWNER.  
B. FERTILIZING - APPLY 16-6-8 AT THE RATE OF 5 POUNDS PER 1,000 SQUARE FEET THREE WEEKS AFTER INSTALLATION AND WATER IMMEDIATELY THEREAFTER.  
C. DISEASES AND PEST CONTROL - TWO WEEKS AFTER INSTALLATION OF LAWN, APPLY A GRANULAR MERCURIAL FUNGICIDE OF 1.8% MERCUROUS CHLORIDE AS PER MANUFACTURER'S RECOMMENDATION.  
D. MOWING - THE LAWN SHALL BE MOWED AT A HEIGHT OF 1-1/2" WITH A ROTARY MOWER, EQUIPPED WITH ROLLERS, BEFORE IT REACHES 2" IN HEIGHT. COLLECT GRASS CLIPPING DURING MOWING OPERATIONS AND REMOVE FROM THE SITE.
27. GROUNDCOVER AND SHRUB AREA MAINTENANCE  
A. WATERING - NEW PLANTINGS SHALL BE WATERED ONCE PER DAY FOR TWO (2) WEEKS AFTER INSTALLATION. REDUCE WATERING TO EVERY OTHER DAY FOR THE NEXT TWO (2) WEEKS. WATER THEREAFTER THREE (3) TIMES PER WEEK UNTIL FINAL ACCEPTANCE.  
B. FERTILIZATION - FERTILIZE THREE (3) WEEKS AFTER PLANTING WITH 5 POUNDS 16-6-8 PER 1,000 SQUARE FEET; FERTILIZE THEREAFTER EVERY THIRTY (30) DAYS.  
C. DISEASE AND PEST CONTROL - FOR CONTROL OF SLUGS AND SNAILS, APPLY PELLETED TRICALCIUM ARSINATE 5% BY WEIGHT AND METALDEHYDE 5% BY WEIGHT AS PER MANUFACTURER'S RECOMMENDATIONS TWO (2) WEEKS AFTER INSTALLATION.  
D. PRUNING - ALL SHRUBS AND TREES SHALL BE PINCH PRUNED AS NECESSARY TO ENCOURAGE NEW GROWTH AND TO ELIMINATE RANK SUCKER GROWTH. OLD FLOWERS, AND DEAD FOLIAGE AND LIMBS SHALL BE REMOVED. NO MAJOR PRUNING SHALL BE DONE WITHOUT THE APPROVAL OF THE L.A.  
E. WEEDING - ALL PLANTING AREAS INCLUDING LAWN, GROUNDCOVER AND SHRUB AREAS SHALL BE KEPT WEED-FREE AT ALL TIMES. WEED SHALL BE DUG OUT BY THE ROOTS AND DISPOSED OF OFF SITE, UPON COMPLETION OF THE DAY MAINTENANCE PERIOD, THE CONTRACTOR SHALL FERTILIZE PER #26 - LAWN MAINTENANCE AND #27 GROUNDCOVERS AND SHRUB AREA MAINTENANCE OF THESE SPECIFICATIONS.
28. GUARANTEE AND REPLACEMENTS  
A. ALL SHRUBS AND GROUNDCOVER SHALL BE GUARANTEED BY CONTRACTOR AS TO GROWTH AND HEALTH FOR A PERIOD OF ONE HUNDRED EIGHTY (180) DAYS AFTER COMPLETION OF THE SPECIFIED MAINTENANCE PERIOD, AND/OR FINAL ACCEPTANCE BY THE L.A. ALL TREES SHALL BE GUARANTEED BY CONTRACTOR TO LIVE AND GROW IN AN ACCEPTABLE UPRIGHT POSITION FOR A PERIOD OF (1) YEAR AFTER COMPLETION OF THE SPECIFIED MAINTENANCE PERIOD, AND/OR FINAL ACCEPTANCE BY THE L.A.  
B. ALL PLANTS THAT SHOW SIGNS OF FAILING GROWTH AT ANY TIME DURING THE LIFE OF THE CONTRACT, INCLUDING THE MAINTENANCE PERIOD, OR THOSE PLANTS INJURED OR DAMAGED AS TO RENDER THEM UNSUITABLE FOR THE PURPOSE INTENDED, SHALL BE GUARANTEED AS SPECIFIED FOR THE ORIGINAL GUARANTEED MATERIALS.

## CITY OF INDUSTRY

APPROVED BY: \_\_\_\_\_ DATE: \_\_\_\_\_  
CLEMENT N. CALVILLE, PE, RCE 27743 DEPUTY CITY ENGINEER

SAN JOSE AVENUE RECONSTRUCTION  
FROM CHARLIE RD. TO NOGALES STREET

### LANDSCAPE SPECIFICATIONS

DESIGNED BY:	CHECKED BY: -	JOB NO. CITY - MP 08-09	SHT. 12 OF 14
DRAFTED BY:	DATE: APRIL 12, 2022		

CONTRACT DRAWING OF



NO.	DATE	REVISIONS	CK.	BY

CITY OF INDUSTRY  
INCORPORATED JUNE 18, 1957  
P.O. Box 3366, City of Industry, California 91744  
Administrative Offices: 15625 Mayor Dave Way (626) 333-2211

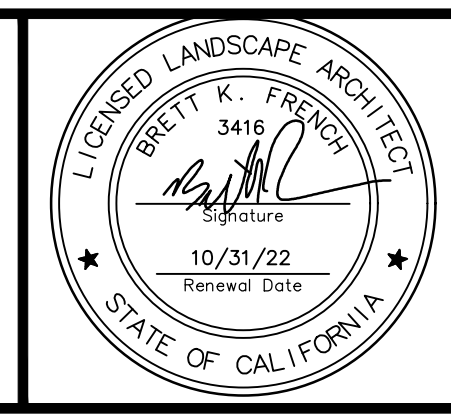

Prepared by: **Environs** INC  
LANDSCAPE ARCHITECTURE  
Creating Sustainable & Water Conserving Solutions  
801 El Berrero • San Clemente, CA 92672  
PH (949) 636-4663  
Signature: \_\_\_\_\_ DATE: 4-12-22  
BRET FRENCH, RLA #3416  
DESIGN BY: BKF DRAWN BY: BKF

29. CLEAN-UP  
UPON COMPLETION OF THE WORK IN THIS SECTION, CONTRACTOR SHALL REMOVE ALL RUBBISH, TRASH AND DEBRIS RESULTING FROM THE OPERATIONS; REMOVE DISUSED EQUIPMENT AND IMPLEMENTS OF SERVICE; LEAVE ENTIRE AREA INVOLVED IN A NEAT AND ACCEPTABLE CONDITION SUCH AS TO MEET THE APPROVAL OF THE LANDSCAPE ARCHITECT (L.A.).

HYDROSEED

1. GENERAL  
A. EQUIPMENT MUST HAVE MINIMUM CAPACITY OF 1,500 GALLONS AND A POSITIVE DISPLACEMENT PUMP WITH THE ABILITY TO AGITATE AND PROPERLY MIX THE SPECIFIED MATERIALS. PUMP MUST BE CAPABLE OF CREATING 100 POUNDS PSI PRESSURE WITH SUFFICIENT VOLUME TO DISTRIBUTE ABOVE SLURRY EVENLY OVER 12,000 SQ. FT. WITHIN A 15-MINUTE PERIOD.

B. VENDOR FURNISHED LABEL: VENDOR AGREES TO FURNISH NOT LESS THAN TWO (2) EMPLOYEES DURING ALL HYDROMULCHING APPLICATIONS.  
C. THE VENDOR SHALL FULLY GUARANTEE HIS WORK AND SERVICES AND SHALL BE FULLY INSURED AND BE PREPARED TO FURNISH SATISFACTORY EVIDENCE OF SUCH INSURANCE UPON DEMAND.

2. SLOPE & PLANTING AREA PREPARATION  
A. SCARIFICATION - PRIOR TO INSTALLATION OF THE IRRIGATION SYSTEM, THE SURFACE OF ALL SLOPES SHALL BE CLEANED AND GRUBBED TO PREPARE THE SLOPE SURFACE FOR SEEDING.

B. MULCH - TO BE SILVA FIBER PLUS (AT 2,000 POUNDS PER ACRE), A GREEN COLORED, FIBROUS MULCH, CONTAINING NO GROWTH OR GERMINATION INHIBITING FACTORS. SILVA FIBER PLUS IS MANUFACTURED IN SUCH A MANNER THAT AFTER ADDITION OF SEED, FERTILIZER, WATER AND ADDITIVES IN A SPECIAL 1500-GALLON SLURRY TANK, THE FIBERS AND ABOVE-MATERIALS WILL BECOME UNIFORMLY MIXED TO FORM A HOMOGENEOUS SLURRY; AND USING THE GREEN COLOR TO FACILITATE PROPER DISTRIBUTION, THE SLURRY SHALL BE HYDRAULICALLY SPRAYED ONTO THE GROUND FORMING A BLOTTER-LIKE GROUND COVER WHICH AFTER APPLICATION WILL ALLOW THE ABSORPTION AND RETENTION OF MOISTURE. SUPPLIERS SHALL BE PREPARED TO CERTIFY THAT LABORATORY AND FIELD TESTING OF THEIR PRODUCT HAS BEEN ACCOMPLISHED, AND THAT IT MEETS ALL OF THE FOREGOING REQUIREMENTS, BASED ON TESTING. WEIGHT SPECIFICATIONS OF THIS MATERIAL FROM SUPPLIERS, AND FOR ALL APPLICATION, SHALL REFER ONLY TO AIR DRY WEIGHT OF THE FIBER MATERIAL. ABSOLUTE AIR DRY WEIGHT BASED ON THE NORMAL STANDARDS OF THE TECHNICAL ASSOCIATION OF THE PULP INDUSTRY FOR SILVA FIBER PLUS IS CONSIDERED EQUIVALENT TO 10% MOISTURE. EACH PACKAGE OF SILVA FIBER PLUS SHALL BE MARKED BY THE MANUFACTURER TO SHOW THE AIR DRY WEIGHT CONTENT.

C. SEED MIXES  
TURF SEED MIX: "MARATHON" BY SOUTHLAND SOD  
SLOPE SEED MIX: APPLIED AT LBS. PER ACRE

FUEL MODIFICATION SEED MIX:  
WEED ABATEMENT PROGRAM - UPON COMPLETION OF THE IRRIGATION SYSTEM AND AFTER ALL EXISTING WEEDS HAVE BEEN REMOVED FROM THE PLANTING AREAS, THE FOLLOWING WEED PREVENTION SHALL BE USED:

APPLY FERTILIZER MIXTURE BY SPRAY PER ACRE AS FOLLOWS:  
300 LBS. 12-12-12 COMMERCIAL FERTILIZER  
300 LBS. UREA FORMALDEHYDE  
1000 LBS. AGRICULTURAL GYPSUM

APPLY PRE-EMERGENT HERBICIDE AS RECOMMENDED BY A LICENSED PEST CONTROL ADVISOR TO BE COMPATIBLE WITH THE SEEDING PLANT VARIETIES.  
APPLY MIXTURES PER THE FOLLOWING TIME SCHEDULE:

FERTILIZE/WATER	21 DAYS
WAIT	2 DAYS
SPRAY THE PRE-EMERGENT PER PEST CONTROL ADVISOR RECOMMENDATIONS	7-10 DAYS
FERTILIZE/WATER	14 DAYS
SPRAY WEED MIXTURE	7 DAYS
FERTILIZE/WATER	14 DAYS
SPRAY WEED MIXTURE	7 DAYS
GRUB/CLEAN ALL AREAS TO PREPARE FOR SEEDING	2 DAYS
PLANT	23 DAYS MAXIMUM
TOTAL	100 DAYS MAXIMUM

3. PLANTING  
A. TREES AND SHRUBS - TREES AND SHRUBS CAN BE PLANTED AFTER WEED GERMINATION AND DURING THE CONTACT KILL OF WEEDS, AS SPECIFIED.

B. HYDROSEEDING  
(1) WHEN ALL WEEDS HAVE BEEN ELIMINATED TO THE SATISFACTION OF THE LANDSCAPE ARCHITECT AND THE OWNER'S AUTHORIZED REPRESENTATIVE, THE HYDROSEEDING OPERATION MAY BEGIN.  
(2) THE MATERIALS FOR SEEDING AREAS SHALL BE MACHINE MIXED BEFORE APPLICATION.  
(3) THE MIXTURE OF STOLONS OR SEED AND ADDITIVES ARE TO BE APPLIED BY A HYDRO-MULCHING MACHINE. THE NOZZLE HEIGHT SHALL BE BETWEEN 6' AND 10' ABOVE THE GROUND LEVEL. DISCHARGED PRESSURE AT THE NOZZLE SHALL BE 100 PSI.  
(4) SPRAYING SHALL BE DONE IN A SWEEPING MOTION ALLOWING THE SLURRY TO FALL EVENLY AND EVENTUALLY BUILD UP A CONSISTENT MATTING.  
(5) SOIL MOISTURE: AREA TO BE PLANTED SHALL BE IRRIGATED TO OBTAIN 12 INCHES OF PENETRATION. THIS SHOULD BE DONE 4 TO 7 DAYS PRIOR TO PLANTING.

C. MIXTURE  
(1) COMMERCIAL FERTILIZER SHALL BE APPLIED AT THE FOLLOWING RATES: 500 LBS./ACRE...16-20-0 (BEST FERTILIZER COMPANY CROP MAKER OR EQUAL)  
(2) FIBER MATERIAL (CONWED 2000) AT THE RATE OF 2,000 LBS./ACRE.  
(3) WATER WITH MIXTURE OF 3,000 GALLONS/ACRE.  
(4) STABILIZING BINDER - 120 LBS/ACRE FOR SLOPES, 80 LBS/ACRE FOR FLAT AREAS

D. WATERING - IMMEDIATELY AFTER PLANTING, THE SLOPES AND OTHER PLANTING AREAS SHALL BE WATERED WITH A FINE SPRAY, CARE BEING TAKEN TO AVOID EROSION, AND THE PLANTED AREA KEPT MOIST UNTIL THE SEED HAS GERMINATED (OR THE PLANTS HAVE BECOME ESTABLISHED).

E. CLEAN-UP - AFTER COMPLETION OF THE WORK, ALL RUBBISH AND SURPLUS MATERIAL SHALL BE REMOVED FROM THE SITE, AND IT SHALL BE LEFT NEAT AND CLEAN.

4. PLANT ESTABLISHMENT  
A. IRRIGATION - THE IRRIGATION SYSTEM WILL BE OPERATED TO PROVIDE AN OPTIMUM AMOUNT OF SURFACE MOISTURE FOR GERMINATION OF THE SEEDED VARIETIES AVOIDING ALL RUN-OFF AND DEEP SATURATION OF WATER.

B. FERTILIZATION - THE AREA SHALL BE HYDRO-FERTILIZED EVERY 30 DAYS AFTER PLANTING WITH THE FOLLOWING COMBINATION OF MATERIALS: 250 LBS./ACRE...16-6-8 (BEST FERTILIZER COMPANY CROP MAKER OR EQUAL)

C. PRE-EMERGENT HERBICIDE - SIXTY (60) DAYS AFTER PLANTING, APPLY A BROAD SPECTRUM PRE-EMERGENT HERBICIDE AS RECOMMENDED BY AN EXPERIENCED LICENSED PEST CONTROL ADVISOR.

5. MAINTENANCE  
A. MAINTENANCE OF THE PROJECT SHALL BE FOR A PERIOD OF 180 DAYS.

B. MAINTENANCE SHALL INCLUDE ALL WATERING, FERTILIZATION, MOWING, WEEDING, CULTIVATING, SPRAYING AND PRUNING NECESSARY TO KEEP THE PLANT MATERIALS IN A HEALTHY GROWING CONDITION AND TO KEEP THE PLANTED AREAS NEAT AND ATTRACTIVE THROUGHOUT THE MAINTENANCE PERIOD.

C. PROTECT ALL PLANTED AREAS AGAINST DAMAGE, INCLUDING EROSION AND TRESSPASSING, BY PROVIDING AND MAINTAINING PROPER SAFEGUARDS.

D. DURING THE MAINTENANCE PERIOD, ALL PLANTED AREAS SHALL BE KEPT WELL WATERED AND WEED-FREE AT ALL TIMES.

E. FROM THE TIME ANY PLANTING IS DONE, UNTIL THE END OF THE MAINTENANCE PERIOD, THE CONTRACTOR SHALL MAINTAIN A SUFFICIENT NUMBER OF MEN AND ADEQUATE EQUIPMENT TO PERFORM THE WORK HEREIN SPECIFIED.

F. THE CONTRACTOR WILL BE RELIEVED FROM MAINTENANCE WORK WHEN THE FINAL PLANT ESTABLISHMENT AND MAINTENANCE WORK HAS BEEN COMPLETED TO THE SATISFACTION OF THE OWNER.

G. DAMAGE TO PLANTING AREAS SHALL BE REPLACED IMMEDIATELY AT THE CONTRACTOR'S EXPENSE.

H. DEPRESSIONS CAUSED BY VEHICLES, BICYCLES, OR FOOT TRAFFIC, SHALL BE FILLED AND LEVELED. REPLANT DAMAGED AREAS.

I. EXTERMINATE GOPHERS AND MOLES, GROUND SQUIRRELS, AND REPAIR DAMAGE AS ABOVE.

J. ALL PAVED AREAS WILL BE WASHED AND MAINTAINED IN A NEAT AND CLEAN CONDITION AT ALL TIMES, AS DIRECTED BY THE OWNER.

K. PINCH-PRUNE ALL SHRUBS AND TREES TO ENCOURAGE NEW GROWTH AND TO ELIMINATE RANK SUCKER GROWTH. REMOVE ALL OLD FLOWERS AND DEAD FOLIAGE AND LIMBS. DO NO MAJOR PRUNING WITHOUT THE APPROVAL OF THE OWNER. REMOVE DAMAGED BRANCHES ON TREES BACK TO POINT OF GROWTH. TREAT CUTS OVER 2" IN DIAMETER WITH AN APPROVED TREE WOUND DRESSING.

L. DURING THE MAINTENANCE PERIOD, SHOULD THE APPEARANCE OF ANY PLANT INDICATE WEAKNESS AND PROBABILITY OF DYING, IMMEDIATELY REPLACE THAT PLANT WITH A NEW AND HEALTHY PLANT OF THE SAME TYPE AND SIZE WITHOUT ADDITIONAL COST TO THE OWNER.

M. AT THE END OF THE MAINTENANCE PERIOD, ALL PLANT MATERIAL SHALL BE IN A HEALTHY GROWING CONDITION.

N. CONTRACTOR SHALL CONTINUE THE MAINTENANCE PERIOD PAST THE SPECIFIED DATE AT NO ADDITIONAL COST TO THE OWNER UNTIL ALL DEFICIENCIES HAVE BEEN CORRECTED.

## IRRIGATION

1. SCOPE  
FURNISH ALL MATERIALS, TOOLS, EQUIPMENT AND LABOR REQUIRED TO INSTALL A COMPLETE OPERABLE IRRIGATION SYSTEM AS INDICATED ON THE DRAWINGS, AS SPECIFIED AND AS NECESSARY TO COMPLETE THE CONTRACT, INCLUDING, BUT NOT LIMITED TO, THESE MAJOR ITEMS:

A. IRRIGATION SYSTEM AND RELATED APPURTENANCES.  
B. CONNECTIONS TO WATER AND ELECTRICAL UTILITIES.  
C. EXCAVATION AND BACKFILL OF PIPE TRENCHES.  
D. RECORD DRAWINGS AND GUARANTEES.  
E. PERMITS AND LICENSES.  
F. TESTING OF COMPLETED SYSTEMS.

2. QUALITY ASSURANCE  
A. QUALIFICATIONS OF INSTALLERS - PROVIDE AT LEAST ONE PERSON WHO SHALL BE PRESENT AT ALL TIMES DURING EXECUTION OF THIS PORTION OF THE WORK AND WHO SHALL BE THOROUGHLY FAMILIAR WITH THE TYPE OF MATERIALS BEING INSTALLED AND THE MATERIAL MANUFACTURERS' RECOMMENDED METHODS OF INSTALLATION AND WHO SHALL DIRECT ALL WORK PERFORMED UNDER THIS SECTION.

B. CODES AND STANDARDS - IN ADDITION TO COMPLYING WITH ALL PERTINENT CODES AND REGULATION, COMPLY WITH THE LATEST RULES OF THE NATIONAL ELECTRICAL CODE AND THE ELECTRICAL SAFETY ORDERS OF THE STATE OF CALIFORNIA, DIVISION OF INDUSTRIAL SAFETY ORDERS OF THE STATE OF CALIFORNIA, DIVISION OF INDUSTRIAL SAFETY, FOR ALL ELECTRICAL WORK AND MATERIALS.

3. SUBMITTALS  
A. MATERIALS LIST - WITHIN THIRTY-FIVE (35) CALENDAR DAYS AFTER AWARD OF CONTRACT, AND BEFORE ANY IRRIGATION SYSTEM MATERIALS ARE DELIVERED TO THE JOB SITE, SUBMIT TO THE OWNER A COMPLETE LIST OF ALL IRRIGATION SYSTEM MATERIALS PROPOSED TO BE FURNISHED AND INSTALLED.

(1) SHOW MANUFACTURER'S NAME AND CATALOG NUMBER FOR EACH ITEM; FURNISH THE MANUFACTURER'S RECOMMENDATIONS AS TO METHOD OF INSTALLATION.  
(2) UPON APPROVAL BY THE OWNER, THE MANUFACTURER'S RECOMMENDATIONS SHALL BECOME THE BASIS FOR ACCEPTANCE OR REJECTION OF ACTUAL METHODS OF INSTALLATION USED IN THE WORK.  
(3) DO NOT PERMIT ANY IRRIGATION SYSTEM COMPONENT TO BE BROUGHT ONTO THE JOB SITE UNTIL IT HAS BEEN APPROVED BY THE OWNER OR HIS REPRESENTATIVE.

(4) APPROVAL OF ANY ITEM OR ALTERNATE ITEM INDICATES ONLY THAT IT APPARENTLY MEETS THE REQUIREMENTS OF THE DRAWINGS ON THE BASIS OF THE INFORMATION SUBMITTED, AND DOES NOT RELIEVE CONTRACTOR OF ANY RESPONSIBILITY.

B. AS-BUILT DRAWINGS  
(1) DURING THE COURSE OF INSTALLATION, CAREFULLY SHOW IN RED LINE ON A PRINT OF THE IRRIGATION SYSTEM DRAWINGS ALL CHANGES MADE TO THE IRRIGATION SYSTEM DURING INSTALLATION.  
(2) DIMENSION FROM EASILY IDENTIFIABLE PERMANENT FEATURES (BUILDINGS, MONUMENTS, SIDEWALKS, PAVEMENT, ETC.) POINTS OF CONNECTION (WATER AND ELECTRICAL), WIRE ROUTING, SPRINKLER MAIN ROUTING, VALVE LOCATIONS AND OTHER RELATED EQUIPMENT AS DIRECTED BY OWNER.  
(3) UPON COMPLETION OF THE IRRIGATION SYSTEM INSTALLATION, CAREFULLY TRANSFER THE AS-BUILT DATA TO REPRODUCIBLES AS SPECIFIED IN THE GENERAL CONDITIONS AND SUBMIT ONE LEGIBLE COPY AS DESCRIBED UNDER "AS-BUILTS" BELOW, TO THE OWNER.

C. SUBMITTAL OF "AS-BUILTS" - UPON COMPLETION OF THE IRRIGATION SYSTEM INSTALLATION, AND AS A CONDITION OF ITS ACCEPTANCE, DELIVER TO THE OWNER THE AS-BUILT DRAWINGS REFERRED TO ABOVE. THE DELIVERY OF THE AS-BUILT DRAWINGS SHALL NOT RELIEVE THE CONTRACTOR OF THE RESPONSIBILITY OF FURNISHING REQUIRED INFORMATION THAT MAY HAVE BEEN OMITTED.

4. PRODUCT HANDLING  
A. PROTECTION - USE ALL MEANS NECESSARY TO PROTECT IRRIGATION SYSTEM MATERIALS BEFORE, DURING, AND AFTER INSTALLATION AND TO PROTECT THE INSTALLED WORK AND MATERIALS OF ALL OTHER TRADES.  
B. REPLACEMENTS - IN THE EVENT OF DAMAGE, IMMEDIATELY MAKE ALL REPAIRS AND REPLACEMENTS NECESSARY TO THE APPROVAL OF THE OWNER AND AT NO ADDITIONAL COST TO THE OWNER.

(1) EXERCISE CARE IN HANDLING, LOADING, UNLOADING AND STORING PLASTIC PIPE AND FITTINGS UNDER COVER UNTIL READY TO INSTALL. TRANSPORT PLASTIC PIPE ONLY ON A VEHICLE WITH A BED LONG ENOUGH TO ALLOW THE PIPE TO LAY FLAT TO AVOID UNDUE BENDING AND CONCENTRATED EXTERNAL LOAD.  
(2) REPAIR ALL DENTED OR DAMAGED PIPE BY CUTTING OUT THE DENTED OR DAMAGED SECTION AND REJOINING WITH A COUPLING.

C. CONNECTION TO UTILITIES  
(1) SOURCE OF WATER AND POWER SUPPLY: VERIFY AND BE FAMILIAR WITH THE LOCATION, SIZE AND DETAIL OF SUBBOILTS PROVIDED AS THE SOURCE OF WATER AND ELECTRICAL SUPPLY TO THE IRRIGATION SYSTEM, AS SHOWN ON THE PLANS. SOURCE OF SUPPLY AND POINT OF CONNECTION SHALL BE EXISTING STUB-OUTS AT APPROXIMATE LOCATIONS AS SHOWN ON PLANS (UNLESS OTHERWISE NOTED).  
(2) EXISTING UTILITIES AND CONDITIONS: PRIOR TO CUTTING INTO THE SOIL, LOCATE ALL CABLES, CONDUITS, SEWER SEPTIC TANKS, AND OTHER UTILITIES AS ARE COMMONLY ENCOUNTERED UNDERGROUND AND TAKE PROPER PRECAUTIONS NOT TO DAMAGE OR DISTURB SUCH IMPROVEMENTS. IF A CONFLICT EXISTS BETWEEN SUCH OBSTACLES AND THE PROPOSED WORK, PROMPTLY NOTIFY THE OWNER WHO WILL ARRANGE FOR RELOCATIONS. PROCEED IN THE SAME MANNER IF ROCK LAYER OR ANY OTHER CONDITIONS ENCOUNTERED UNDERGROUND MAKE CHANGES ADVISABLE.

A. WHERE INVESTIGATION OF SUBSURFACE CONDITIONS HAS BEEN MADE BY A QUALIFIED BODY IN AREAS IN WHICH LOCAL MATERIALS MAY BE OBTAINED, THE CONTRACTOR MAY REQUEST THE USE OF SUCH INFORMATION BUT WILL BE DIRECTLY RESPONSIBLE FOR ITS VERIFICATION AND ACCURACY.

D. INSPECTION  
(1) AT ALL TIMES PERMIT THE OWNER OR HIS AUTHORIZED AGENTS TO VISIT AND OBSERVE THE WORK OR ANY PART THEREOF. MAINTAIN PROPER FACILITIES AND PROVIDE SAFE ACCESS FOR SUCH OBSERVATIONS TO ALL PARTS OF THE WORK. WHERE THE SPECIFICATIONS REQUIRE WORK TO BE TESTED, IT SHALL NOT BE COVERED UP UNTIL TESTED OR APPROVED BY THE OWNER AND GOVERNING AGENCIES. THE CONTRACTOR SHALL BE SOLELY RESPONSIBLE FOR NOTIFYING THE OWNER AND REQUIRED AGENCY (48 HOURS NOTICE MINIMUM REQUIRED), WHERE AND WHEN SUCH WORK IS IN READINESS FOR TESTING. SHOULD ANY WORK BE COVERED WITHOUT SUCH TEST OR APPROVAL, IT SHALL, IF SO ORDERED, BE UNCOVERED AT THE CONTRACTOR'S EXPENSE.

(2) OBSERVATIONS REQUIRED  
A. PRESTART MEETING  
B. LAYOUT OF CONTROL EQUIPMENT AND HEADS.  
C. MAIN LINE PRESSURE TEST AND TRENCH DEPTH CHECK.  
D. LATERAL TRENCH DEPTH CHECK.  
E. COVERAGE TEST AND PREFINAL OBSERVATION.  
F. FINAL OBSERVATION.

E. STANDARD OF INSTALLATION - MATERIAL AND WORKMANSHIP SHALL BE IN ACCORDANCE WITH LOCAL CODES AND ORDINANCES OF LEGALLY CONSTITUTED AUTHORITIES, EXCEPT THAT WHERE PROVISIONS OF THESE SPECIFICATIONS EXCEED SUCH REQUIREMENTS, THESE SPECIFICATIONS SHALL GOVERN.

F. PRESERVATION AND CLEANING - CLEANUP ALL WORK AS IT PROGRESSES. AT FREQUENT INTERVALS, AND AT ALL TIMES WHEN DIRECTED BY THE OWNER, REMOVE AND DISPOSE OF ACCUMULATIONS OF RUBBISH AND DEBRIS OF ALL KINDS. AT THE TIME OF COMPLETION, THE ENTIRE SITE SHALL BE CLEARED OF TOOLS, EQUIPMENT, RUBBISH, ETC., ALL OF WHICH SHALL BE LEFT IN PROPER, CLEAN CONDITION READY FOR ACCEPTANCE.

G. COMPLETION - THE WORK SHALL BE ACCEPTED IN WRITING WHEN THE ENTIRE SCOPE OF WORK HAS BEEN COMPLETED SATISFACTORILY TO THE OWNER. IN JUDGING THE WORK, NO ALLOWANCE FOR DEVIATION FROM THE ORIGINAL PLANS AND SPECIFICATIONS WILL BE MADE UNLESS PREVIOUSLY APPROVED BY THE OWNER.  
(1) WHEN ANY ITEM APPEARS ON THE PLAN AND NOT IN THE SPECIFICATIONS, OR IN THE SPECIFICATIONS AND NOT ON THE PLAN, IT SHALL BE CONSIDERED IN BOTH.  
(2) THE OWNER OR HIS AUTHORIZED REPRESENTATIVE SHALL HAVE THE FINAL AUTHORITY ON ALL ITEMS OF THE PROJECT.

H. EQUIPMENT TO BE FURNISHED - IRRIGATION EQUIPMENT, OPERATING KEYS AND SPARE PARTS SHALL BE FURNISHED TO THE OWNER AS SHOWN ON THE PLANS.

I. SERVICE BY THE CONTRACTOR - THE CONTRACTOR SHALL SERVICE THE SYSTEM AT THE OWNER'S REQUEST DURING THE GUARANTEE PERIOD AND SHALL BE PAID FOR WORK PERFORMED WHICH IS NOT COVERED BY THE GUARANTEE. IF REQUESTED BY THE OWNER, THE CONTRACTOR SHALL FURNISH THE OWNER WITH A SCHEDULE OF SERVICES FEES.

J. FINAL ACCEPTANCE - WITHIN 10 DAYS OF THE CONTRACTOR'S NOTIFICATION THAT THE INSTALLATION IS COMPLETE, THE OWNER AND REQUIRED AGENCIES WILL OBSERVE THE INSTALLATION AND, IF FINAL ACCEPTANCE IS NOT GIVEN, WILL PREPARE A "PUNCH LIST" WHICH, UPON COMPLETION BY THE CONTRACTOR, AND APPROVED BY THE OWNER, WILL SIGNIFY FINAL ACCEPTANCE BY THE OWNER.

K. IRRIGATION GUARANTEE  
(1) THE ENTIRE IRRIGATION SYSTEM SHALL BE UNCONDITIONALLY GUARANTEED BY THE CONTRACTOR AS TO MATERIAL AND WORKMANSHIP, INCLUDING SETTLING OF BACKFILLED AREAS BELOW GRADE FOR A PERIOD OF ONE YEAR FOLLOWING THE DATE OF FINAL ACCEPTANCE OF THE WORK.  
(2) IF, WITHIN ONE YEAR FROM THE DATE OF COMPLETION, SETTLEMENT OCCURS AND ADJUSTMENTS IN PIPE, VALVES, AND IRRIGATION HEADS, SOD OR PAVING TO THE PROPER LEVEL OF THE PERMANENT GRADES, THE CONTRACTOR AS PART OF THE WORK UNDER THIS CONTRACT, SHALL MAKE ALL ADJUSTMENTS WITHOUT EXTRA COST TO THE OWNER, INCLUDING COMPLETE RESTORATION OF ALL DAMAGED PLANTING, PAVING OR OTHER IMPROVEMENTS.  
(3) SHOULD ANY OPERATIONAL DIFFICULTIES IN CONNECTION WITH THE IRRIGATION SYSTEM DEVELOP WITHIN THE SPECIFIED GUARANTEE PERIOD, WHICH IN THE OPINION OF THE OWNER MAY BE DUE TO INFERIOR MATERIAL OR WORKMANSHIP, SAID DIFFICULTIES SHALL BE IMMEDIATELY REPAIRED AT NO ADDITIONAL COST TO THE OWNER, INCLUDING ANY AND ALL OTHER DAMAGE CAUSED BY SUCH DEFECTS.

L. PERMITS AND LICENSES - UNLESS OTHERWISE STATED, SECURE THE REQUIRED LICENSES AND PERMITS INCLUDING PAYMENTS OF CHARGES AND FEES, GIVE REQUIRED NOTICES TO PUBLIC AUTHORITIES, AND VERIFY PERMITS SECURED OR ARRANGEMENTS MADE BY OTHERS AFFECTING THE WORK OF THIS SECTION.

5. MATERIALS  
MATERIALS LISTED IN THIS SECTION ENCOMPASS THE GENERAL ITEMS ENCOUNTERED. IF PRODUCTS LISTED BELOW ARE NOT USED FOR THE PROJECT BEING INSTALLED, THEY ARE TO BE OMITTED.

6. PIPE  
A. PVC  
(1) PVC PRESSURE RATED PIPE - TYPE 1220 (PVC CLASS 200 AND 315 AND PVC SCHEDULE 40-1120).

A. TYPE I GRADE II PRESSURE RATED PIPE.  
B. MATERIALS SHALL MEET REQUIREMENTS SET FORTH IN THE ASTM CURRENT STANDARDS.  
C. OUTSIDE DIAMETER OF PIPE SHALL BE THE SAME SIZE AS IRON PIPE.  
D. PIPE SHALL BE MARKED AT INTERVALS NOT TO EXCEED 5 FEET WITH THE FOLLOWING INFORMATION: MANUFACTURER'S NAME, NOMINAL PIPE SIZE, PVC TYPE AND GRADE (I.E. PVC 1220), S.D.R. RATING CLASS, NSF APPROVAL AND COMMERCIAL STANDARD DESIGNATION CS 256-63.  
E. PVC PIPE SHALL COMPLY WITH STANDARDS SET FORTH IN CS 256-63.  
F. PVC TYPE I SHALL NOT BE THREADED.  
G. PVC FITTINGS SHALL BE SCHEDULE 40 OR 80, PVC TYPE II.  
H. SOLVENT SHALL BE #715 GRAY NSF APPROVED AS MANUFACTURED BY INDUSTRIAL POLYCHEMICAL SERVICE, GARDENA, CALIFORNIA, OR APPROVED EQUAL.

I. TYPE II GRADE I HIGH IMPACT PIPE.  
B. OUTSIDE DIAMETER OF PIPE SHALL BE THE SAME SIZE AS IRON PIPE.  
C. PIPE SHALL BE MARKED AT INTERVALS NOT TO EXCEED 5 FEET WITH THE FOLLOWING INFORMATION: MANUFACTURER'S NAME, NOMINAL PIPE SIZE, PVC TYPE AND GRADE (I.E. PVC 2110), SCHEDULE, NSF APPROVAL AND COMMERCIAL STANDARD DESIGNATION CS 207-60.  
D. PVC PIPE SHALL COMPLY WITH STANDARDS SET FORTH IN CS 207-60.  
E. PVC SCHEDULE 40 SHALL NOT BE THREADED.  
F. FITTINGS SHALL BE PVC SCHEDULE 40 OR 80, TYPE II, NSF APPROVED, AS REQUIRED.  
G. ALL THREADED PVC PIPE SHALL BE SCHEDULE 80, TYPE 2110.  
H. SOLVENT SHALL BE #175 OR #710 GRAY, NSF APPROVED AS MANUFACTURED BY INDUSTRIAL POLYCHEMICAL SERVICE, GARDENA, CALIFORNIA, OR APPROVED EQUAL.

(3) UVR - PVC - "BROWNLINE" PIPE  
WHERE CALLED FOR ON GRADE PIPE SHALL BE UVR - PVC PIPE ANCHORED AT 10' INTERVALS WITH RE-BAR. ALL UVR - PVC PIPE SHALL BE INSTALLED PER MANUFACTURER'S RECOMMENDATIONS.  
(4) WHEN CONNECTION IS PLASTIC TO METAL, MALE ADAPTERS SHALL BE USED. THE MALE ADAPTER SHALL BE HAND TIGHTENED, PLUS ONE TURN WITH A STRAP WRENCH. JOINT COMPOUND SHALL BE NONHARDENING SEALING COMPOUND COMPATIBLE TO PLASTICS. COMPOUND MUST NOT LUBRICATE THE JOINT.

B. BRASS PIPE  
(1) WHERE INDICATED ON THE DRAWINGS, BRASS PIPE SHALL BE RED BRASS SCREWED PIPE CONFORMING TO FEDERAL SPECIFICATION #WW-P-351.  
(2) FITTINGS SHALL BE RED BRASS CONFORMING TO FEDERAL SPECIFICATION WW-P-460.

C. GALVANIZED PIPE  
(1) WHERE INDICATED ON THE DRAWINGS, GALVANIZED STEEL PIPE SHALL BE ASA SCHEDULE 40, MILD STEEL SCREWED PIPE.  
(2) FITTINGS SHALL BE MEDIUM GALVANIZED SCREWED BEADED MALLEABLE IRON. GALVANIZED COUPLINGS MAYBE MERCHANT COUPLING.  
(3) ALL GALVANIZED PIPE AND FITTINGS INSTALLED BELOW GRADE SHALL BE PAINTED WITH TWO (2) COATS OF KOPPERS #50 BITUMASTIC AND WRAPPED WITH 20 MIL TAPE.  
(4) ALL NONDOMESTIC GALVANIZED PIPE INSTALLED ON GRADE SHALL BE STENCILED OR IDENTIFIED WITH GREEN TAPE AT ALL CONNECTIONS AND CONTINUOUSLY ALONG ITS LENGTH.

D. COPPER PIPE AND FITTINGS - WHERE INDICATED ON THE DRAWINGS, COPPER PIPE SHALL BE TYPE "K" SWEAT SOLDERED PIPE.

7. RISERS  
ALL SPRINKLER HEADS SHALL HAVE RISERS AS SHOWN IN THE DETAIL DRAWINGS.

8. VALVES  
A. GATE VALVES  
(1) GATE VALVES 3" AND SMALLER SHALL BE 125 LB. SWP BRONZE GATE VALVE WITH SCREW-IN BONNET, NONRISING STEM AND SOLID WEDGE DISC.  
(2) GATE VALVES 3" AND SMALLER SHALL HAVE THREADED ENDS AND SHALL BE EQUIPPED WITH A BRONZE HAND WHEEL OR OPERATING NUTS.  
(3) GATE VALVES 3" AND SMALLER SHALL BE SIMILAR TO THOSE MANUFACTURED BY KENNEDY OR APPROVED EQUAL.  
(4) ALL GATE VALVES SHALL BE INSTALLED PER DETAILED DRAWINGS.

B. QUICK COUPLING VALVES - QUICK COUPLING VALVES SHALL BE OF MANUFACTURER SHOWN ON THE DRAWINGS OR APPROVED EQUAL. EACH QUICK COUPLER SHALL HAVE A MOLDED VINYL LOCKING COVER. UPON COMPLETION OF THE CONTRACT AND PRIOR TO FINAL ACCEPTANCE, SUPPLY THE OWNER WITH QUICK COUPLER KEYS AND HOSE ELLS OF THE QUANTITY CALLED FOR ON THE PLANS. THE QUICK COUPLER KEYS AND HOSE ELLS SHALL BE OF THE SAME MANUFACTURER AS THE COUPLING VALVE. ALL QUICK COUPLING VALVES SHALL BE INSTALLED PER DETAILED DRAWINGS.

C. REMOTE CONTROL VALVES  
(1) THE ELECTRIC REMOTE CONTROL VALVES SHALL BE OF THE TYPE AND MANUFACTURER SHOWN ON THE DRAWINGS, OR APPROVED EQUAL, AND INSTALLED PER DETAILED DRAWINGS AND MANUFACTURER'S RECOMMENDATIONS.  
(2) VALVES SHALL BE INSTALLED MINIMUM 6" FROM ALL FIXED OBJECTS AND 12" APART.  
D. PRESSURE REGULATING VALVES - PRESSURE REGULATING VALVES SHALL BE OF THE TYPE AND MANUFACTURER SHOWN ON THE DRAWINGS, OR APPROVED EQUAL, AND INSTALLED PER DETAILED DRAWINGS AND MANUFACTURER'S RECOMMENDATIONS.  
E. CHECK VALVES - ANTI-DRAIN VALVES SHALL BE OF HEAVY DUTY VIRGIN PVC OR BRASS CONSTRUCTION WITH F.I.P. THREADED INLET AND OUTLET. INTERNAL PARTS SHALL BE STAINLESS STEEL AND NEOPRENE. ANTI-DRAIN VALVES SHALL BE FIELD ADJUSTABLE AGAINST DRAIN OUT FROM 5 TO 40 FEET OF HEAD. THE ANTI-DRAIN VALVE, WHERE INDICATED ON THE PLANS, SHALL HAVE AN EXCESS FLOW FEATURE WHICH WILL AUTOMATICALLY STOP THE FLOW OF WATER WHEN IT EXCEEDS THE GPM PRESET BY THE MANUFACTURER. THE ANTI-DRAIN AND EXCESS FLOW VALVE SHALL BE SIMILAR TO THE VALCON ADV-XS, RAIN BIRD SM-1 OR APPROVED EQUAL. SPRINKLER HEADS HAVING CHECK VALVES IN HEADS WILL NOT REQUIRE ADDITIONAL CHECK VALVES.

9. VALVE BOXES  
ALL VALVES, INCLUDING PRESSURE REGULATING VALVES, REMOTE CONTROL VALVES AND GATE VALVES SHALL BE INSTALLED IN SUITABLE VALVE BOXES AS SHOWN IN DETAILS. ALL SHALL BE MARKED "PRV", "RCV", OR "GV" RESPECTIVELY WITH STATION NUMBERS FOR CONTROL VALVES STENCILED IN WHITE ON THE VALVE COVER. (RCV BOXES SHALL HAVE LOCKING COVERS.)

I. CAUTION SHALL BE UTILIZED IN HANDLING TYPE I PIPE DUE TO THE POSSIBILITY OF CRACKING OR SPLITTING WHEN DROPPED OR HANDLED CARELESSLY.  
J. PIPE SHALL BE BELL END, CONFORMING TO ASTM-D-2672. INSTALL CONCRETE THRUST BLOCKS AS RECOMMENDED IN JOHNS-MANSVILLE INSTALLATION GUIDE NO. TR-624, WHERE CONDITIONS DICTATE.

(2) PVC HIGH IMPACT PIPE - TYPE 2110 (PVC SCHEDULE 40 AND 80).

A. TYPE II GRADE I HIGH IMPACT PIPE.  
B. OUTSIDE DIAMETER OF PIPE SHALL BE THE SAME SIZE AS IRON PIPE.  
C. PIPE SHALL BE MARKED AT INTERVALS NOT TO EXCEED 5 FEET WITH THE FOLLOWING INFORMATION: MANUFACTURER'S NAME, NOMINAL PIPE SIZE, PVC TYPE AND GRADE (I.E. PVC 2110), SCHEDULE, NSF APPROVAL AND COMMERCIAL STANDARD DESIGNATION CS 207-60.  
D. PVC PIPE SHALL COMPLY WITH STANDARDS SET FORTH IN CS 207-60.  
E. PVC SCHEDULE 40 SHALL NOT BE THREADED.  
F. FITTINGS SHALL BE PVC SCHEDULE 40 OR 80, TYPE II, NSF APPROVED, AS REQUIRED.  
G. ALL THREADED PVC PIPE SHALL BE SCHEDULE 80, TYPE 2110.  
H. SOLVENT SHALL BE #175 OR #710 GRAY, NSF APPROVED AS MANUFACTURED BY INDUSTRIAL POLYCHEMICAL SERVICE, GARDENA, CALIFORNIA, OR APPROVED EQUAL.

(3) UVR - PVC - "BROWNLINE" PIPE  
WHERE CALLED FOR ON GRADE PIPE SHALL BE UVR - PVC PIPE ANCHORED AT 10' INTERVALS WITH RE-BAR. ALL UVR - PVC PIPE SHALL BE INSTALLED PER MANUFACTURER'S RECOMMENDATIONS.  
(4) WHEN CONNECTION IS PLASTIC TO METAL, MALE ADAPTERS SHALL BE USED. THE MALE ADAPTER SHALL BE HAND TIGHTENED, PLUS ONE TURN WITH A STRAP WRENCH. JOINT COMPOUND SHALL BE NONHARDENING SEALING COMPOUND COMPATIBLE TO PLASTICS. COMPOUND MUST NOT LUBRICATE THE JOINT.

B. BRASS PIPE  
(1) WHERE INDICATED ON THE DRAWINGS, BRASS PIPE SHALL BE RED BRASS SCREWED PIPE CONFORMING TO FEDERAL SPECIFICATION #WW-P-351.  
(2) FITTINGS SHALL BE RED BRASS CONFORMING TO FEDERAL SPECIFICATION WW-P-460.

C. GALVANIZED PIPE  
(1) WHERE INDICATED ON THE DRAWINGS, GALVANIZED STEEL PIPE SHALL BE ASA SCHEDULE 40, MILD STEEL SCREWED PIPE.  
(2) FITTINGS SHALL BE MEDIUM GALVANIZED SCREWED BEADED MALLEABLE IRON. GALVANIZED COUPLINGS MAYBE MERCHANT COUPLING.  
(3) ALL GALVANIZED PIPE AND FITTINGS INSTALLED BELOW GRADE SHALL BE PAINTED WITH TWO (2) COATS OF KOPPERS #50 BITUMASTIC AND WRAPPED WITH 20 MIL TAPE.  
(4) ALL NONDOMESTIC GALVANIZED PIPE INSTALLED ON GRADE SHALL BE STENCILED OR IDENTIFIED WITH GREEN TAPE AT ALL CONNECTIONS AND CONTINUOUSLY ALONG ITS LENGTH.

D. COPPER PIPE AND FITTINGS - WHERE INDICATED ON THE DRAWINGS, COPPER PIPE SHALL BE TYPE "K" SWEAT SOLDERED PIPE.

7. RISERS  
ALL SPRINKLER HEADS SHALL HAVE RISERS AS SHOWN IN THE DETAIL DRAWINGS.

8. VALVES  
A. GATE VALVES  
(1) GATE VALVES 3" AND SMALLER SHALL BE 125 LB. SWP BRONZE GATE VALVE WITH SCREW-IN BONNET, NONRISING STEM AND SOLID WEDGE DISC.  
(2) GATE VALVES 3" AND SMALLER SHALL HAVE THREADED ENDS AND SHALL BE EQUIPPED WITH A BRONZE HAND WHEEL OR OPERATING NUTS.  
(3) GATE VALVES 3" AND SMALLER SHALL BE SIMILAR TO THOSE MANUFACTURED BY KENNEDY OR APPROVED EQUAL.  
(4) ALL GATE VALVES SHALL BE INSTALLED PER DETAILED DRAWINGS.

B. QUICK COUPLING VALVES - QUICK COUPLING VALVES SHALL BE OF MANUFACTURER SHOWN ON THE DRAWINGS OR APPROVED EQUAL. EACH QUICK COUPLER SHALL HAVE A MOLDED VINYL LOCKING COVER. UPON COMPLETION OF THE CONTRACT AND PRIOR TO FINAL ACCEPTANCE, SUPPLY THE OWNER WITH QUICK COUPLER KEYS AND HOSE ELLS OF THE QUANTITY CALLED FOR ON THE PLANS. THE QUICK COUPLER KEYS AND HOSE ELLS SHALL BE OF THE SAME MANUFACTURER AS THE COUPLING VALVE. ALL QUICK COUPLING VALVES SHALL BE INSTALLED PER DETAILED DRAWINGS.

C. REMOTE CONTROL VALVES  
(1) THE ELECTRIC REMOTE CONTROL VALVES SHALL BE OF THE TYPE AND MANUFACTURER SHOWN ON THE DRAWINGS, OR APPROVED EQUAL, AND INSTALLED PER DETAILED DRAWINGS AND MANUFACTURER'S RECOMMENDATIONS.  
(2) VALVES SHALL BE INSTALLED MINIMUM 6" FROM ALL FIXED OBJECTS AND 12" APART.  
D. PRESSURE REGULATING VALVES - PRESSURE REGULATING VALVES SHALL BE OF THE TYPE AND MANUFACTURER SHOWN ON THE DRAWINGS, OR APPROVED EQUAL, AND INSTALLED PER DETAILED DRAWINGS AND MANUFACTURER'S RECOMMENDATIONS.  
E. CHECK VALVES - ANTI-DRAIN VALVES SHALL BE OF HEAVY DUTY VIRGIN PVC OR BRASS CONSTRUCTION WITH F.I.P. THREADED INLET AND OUTLET. INTERNAL PARTS SHALL BE STAINLESS STEEL AND NEOPRENE. ANTI-DRAIN VALVES SHALL BE FIELD ADJUSTABLE AGAINST DRAIN OUT FROM 5 TO 40 FEET OF HEAD. THE ANTI-DRAIN VALVE, WHERE INDICATED ON THE PLANS, SHALL HAVE AN EXCESS FLOW FEATURE WHICH WILL AUTOMATICALLY STOP THE FLOW OF WATER WHEN IT EXCEEDS THE GPM PRESET BY THE MANUFACTURER. THE ANTI-DRAIN AND EXCESS FLOW VALVE SHALL BE SIMILAR TO THE VALCON ADV-XS, RAIN BIRD SM-1 OR APPROVED EQUAL. SPRINKLER HEADS HAVING CHECK VALVES IN HEADS WILL NOT REQUIRE ADDITIONAL CHECK VALVES.

9. VALVE BOXES  
ALL VALVES, INCLUDING PRESSURE REGULATING VALVES, REMOTE CONTROL VALVES AND GATE VALVES SHALL BE INSTALLED IN SUITABLE VALVE BOXES AS SHOWN IN DETAILS. ALL SHALL BE MARKED "PRV", "RCV", OR "GV" RESPECTIVELY WITH STATION NUMBERS FOR CONTROL VALVES STENCILED IN WHITE ON THE VALVE COVER. (RCV BOXES SHALL HAVE LOCKING COVERS.)

# CITY OF INDUSTRY

APPROVED BY: \_\_\_\_\_  
CLEMENT N. CALVILLO, PE, REG 27743 DEPUTY CITY ENGINEER DATE \_\_\_\_\_

SAN JOSE AVENUE RECONSTRUCTION  
FROM CHARLIE RD. TO NOGALES STREET

## LANDSCAPE SPECIFICATIONS

DESIGNED BY:	CHECKED BY: -	JOB NO. CITY - MP 08-09	SHT. 13 OF 14
DRAFTED BY:	DATE: APRIL 12, 2022		

CONTRACT DRAWING OF



NO.	DATE	REVISIONS	CK.	BY

**CITY OF INDUSTRY**  
INCORPORATED JUNE 18, 1957  
P.O. Box 3366, City of Industry, California 91744  
Administrative Offices: 15625 Mayor Dave Way (626) 333-2211



# IRRIGATION SPECIFICATIONS CONTINUED

10. CONTROLS
- A. **AUTOMATIC CONTROLLER** - AUTOMATIC CONTROLLERS SHALL BE OF THE TYPE AND MANUFACTURER SHOWN ON THE DRAWINGS OR APPROVED EQUAL AND INSTALLED PER MANUFACTURER'S RECOMMENDATIONS AND DETAILED DRAWINGS.
- B. **LOW VOLTAGE CONTROL WIRE** - ALL WIRING TO BE USED FOR CONNECTING THE AUTOMATIC CONTROLLER TO THE ELECTRIC SOLENOID ACTUATED REMOTE CONTROL VALVE SHALL BE TYPE UF-600V, 7-STRAND OR SOLID COPPER, PVC INSULATION, SINGLE CONDUCTOR, UL APPROVED UNDERGROUND FEEDER CABLE. EACH PILOT OR "HOT" WIRE SHALL BE BLACK WITH THE COMMON WIRE BEING WHITE. FIELD SPLICES BETWEEN THE CONTROLLER AND ELECTRIC VALVES ARE NOT PERMITTED. CONTROL WIRE SHALL BE OF THE GAUGE INDICATED ON THE DETAILED DRAWINGS.
- C. **COMMUNICATION CABLE** - COMMUNICATION CABLE FROM THE CENTRAL COMPUTER TO THE FIELD CONTROL UNITS SHALL BE TORO P-716-D A1 CABLE.
- D. **110 VOLT WIRE TO CONTROLLER** - 110 VOLT WIRE SHALL BE PER LOCAL CODE AS TO TYPE AND QUALITY. INSTALL IN CONDUIT 24" BELOW GRADE.
11. BACKFLOW PREVENTION UNITS
- BACKFLOW PREVENTION UNITS SHALL BE OF SIZE AND TYPE AS INDICATED ON THE DRAWINGS. ALL BACKFLOW PREVENTION UNITS SHALL BE INSTALLED IN ACCORDANCE WITH DETAILED DRAWINGS AND THE REQUIREMENTS SET FORTH BY LOCAL CODES AND/OR THE COUNTY HEALTH DEPARTMENT.
12. IRRIGATION HEADS
- A. SPRINKLER HEADS SHALL BE OF THE TYPES AND SIZES WITH THE DIAMETER (OR RADIUS) OF THROW, PRESSURE, DISCHARGE AND OTHER DESIGNATIONS NECESSARY TO DETERMINE THE TYPES AND SIZES AS INDICATED ON THE PLANS. THEY SHALL BE CONSTRUCTED OF BRONZE, BRASS, STAINLESS STEEL AND/OR HIGH IMPACT PLASTIC.
- B. ALL HEADS OF A PARTICULAR TYPE OF FUNCTION IN THE SYSTEM SHALL BE OF THE SAME MANUFACTURER AND SHALL BE MARKED WITH THE MANUFACTURER'S NAME AND IDENTIFICATION IN SUCH A POSITION THAT THEY CAN BE IDENTIFIED WITHOUT BEING REMOVED FROM THE SYSTEM.
13. OTHER MATERIALS
- ALL OTHER MATERIALS NOT SPECIFICALLY DESCRIBED BUT REQUIRED FOR A COMPLETE AND PROPER IRRIGATION SYSTEM INSTALLATION, SHALL BE NEW, FIRST QUALITY OF THEIR RESPECTIVE KINDS, AND SUBJECT TO THE APPROVAL OF THE OWNER.
14. EXECUTION
- A. **INSPECTION**
- PRIOR TO ALL WORK OF THIS SECTION, CAREFULLY INSPECT THE INSTALLED WORK OF ALL OTHER TRADES AND VERIFY THAT ALL SUCH WORK IS COMPLETE TO THE POINT WHERE THIS INSTALLATION MAY PROPERLY COMMENCE.
  - VERIFY THAT THE IRRIGATION SYSTEM WILL BE INSTALLED IN STRICT ACCORDANCE WITH ALL PERTINENT CODES AND REGULATIONS, THE ORIGINAL DESIGN, THE REFERENCE STANDARD AND THE MANUFACTURER'S RECOMMENDATIONS.
  - VERIFY ALL FIELD CONDITIONS INCLUDING PROPERTY LINES, RIGHTS OF WAY, TRACT BOUNDARIES, EASEMENTS AND ANY OTHER LEGAL OR PHYSICAL ELEMENT AS REQUIRED FOR THE SUCCESSFUL COMPLETION OF THE PROJECT.
- B. **DISCREPANCIES**
- IN THE EVENT OF DISCREPANCY, IMMEDIATELY NOTIFY THE CONTRACTOR OR HIS AUTHORIZED REPRESENTATIVE.
  - DO NOT PROCEED WITH INSTALLATION IN AREAS OF DISCREPANCY UNTIL ALL SUCH DISCREPANCIES HAVE BEEN FULLY RESOLVED.
15. FIELD MEASUREMENTS
- MAKE ALL NECESSARY MEASUREMENTS IN THE FIELD TO ENSURE PRECISE FIT OF ITEMS IN ACCORDANCE WITH THE ORIGINAL DESIGN.
16. TRENCHING AND BACKFILLING
- A. **TRENCHING**
- EXCAVATION SHALL BE OPEN VERTICAL CONSTRUCTION SUFFICIENTLY WIDE TO PROVIDE FREE WORKING SPACE AROUND THE WORK INSTALLED AND TO PROVIDE AMPLE SPACE FOR BACKFILLING AND COMPACTING.
  - TRENCHES FOR PIPE SHALL BE CUT TO REQUIRED GRADE LINES, AND TRENCH BOTTOM SHALL BE COMPACTED TO PROVIDE AN ACCURATE GRADE AND UNIFORM BEARING FOR THE FULL LENGTH OF THE PIPE RUN.
  - WHEN TWO PIPES ARE TO BE PLACED IN THE SAME TRENCH, MAINTAIN A SIX-INCH SPACE BETWEEN PIPES AS A MINIMUM. NO PIPE SHALL BE INSTALLED DIRECTLY OVER ANOTHER.
- B. **BACKFILLING**
- BACKFILL MATERIAL SHALL BE APPROVED SOIL. UNSUITABLE MATERIAL, INCLUDING CLODS AND ROCKS OVER 2 1/2" IN SIZE, SHALL BE REMOVED FROM THE PREMISES AND DISPOSED OF LEGALLY AT NO COST TO THE OWNER.
  - ALL BACKFILLING SHALL BE DONE CAREFULLY AND SHALL BE PROPERLY COMPACTED.
  - DEPTH OF TRENCHES SHALL BE SUFFICIENT TO PROVIDE A MINIMUM COVER ABOVE THE TOP OF THE PIPE AS FOLLOWS:
    - 14" OVER NON-PRESSURE ROTOR POP-UP LINES (MINIMUM).
    - 12" OVER NON-PRESSURE LATERAL LINES (MINIMUM).
    - 18" OVER 24 VOLT CONDUIT AND NON-POTABLE IRRIGATION MAIN LINE 3" AND SMALLER (MINIMUM).
    - 24" COVER OVER PIPE SERVING POTABLE WATER TO A BACKFLOW PREVENTER AND 120V CONDUIT (MINIMUM).
    - 30" COVER OVER PIPE CROSSING UNDER PAVING (MINIMUM).
    - SURPLUS EARTH REMAINING AFTER BACKFILLING SHALL BE DISPOSED OF ON THE PREMISES AS DIRECTED BY THE OWNER.

17. INSTALLATION OF PIPE
- A. **GENERAL**
- THE IRRIGATION PIPING LAYOUT IS SCHEMATIC. CONTRACTOR CAN MAKE MINOR ADJUSTMENTS TO THE SYSTEM AS REQUIRED TO AVOID PHYSICAL ELEMENTS OR CONFORM TO OTHER SITE CONDITIONS. IN ALL CASES THERE SHOULD BE NO CONFLICTS BETWEEN THE IRRIGATION SYSTEM, PLANTING, AND STRUCTURAL ELEMENTS. THE CONTRACTOR IS RESPONSIBLE FOR MAINTAINING COVERAGE AS INDICATED, PRIOR APPROVAL OF ANY SUCH ADJUSTMENT FROM THE OWNER AND FOR RECORDING OF ANY SUCH CHANGE.
  - PRIOR TO INSTALLATION, PRESSURE, METER SIZE, SIZE OF SERVICE TO METER, AT EACH POINT OF CONNECTION, MAKE FINAL CONNECTIONS ALLOWING FOR POSSIBLE MINOR DEVIATIONS FROM LOCATIONS SHOWN ON PLANS DUE TO SITE CONDITIONS. ANY DEVIATION FROM DESIGN CRITERIA SHALL BE BROUGHT TO THE ATTENTION OF THE OWNER. CONTINUATION OF WORK SHALL BE AT CONTRACTOR'S RISK AND EXPENSE.
  - VERIFY THE STATIC PRESSURE, METER SIZE, SIZE OF SERVICE TO METER, AT EACH POINT OF CONNECTION, MAKE FINAL CONNECTIONS ALLOWING FOR POSSIBLE MINOR DEVIATIONS FROM LOCATIONS SHOWN ON PLANS DUE TO SITE CONDITIONS. ANY DEVIATION FROM DESIGN CRITERIA SHALL BE BROUGHT TO THE ATTENTION OF THE OWNER. CONTINUATIONS OF WORK SHALL BE AT CONTRACTOR'S RISK AND EXPENSE.
- B. **UNDER EXISTING PAVEMENT**
- PIPE REQUIRED UNDER EXISTING PAVEMENT SHALL BE INSTALLED BY JACKING, BORING OR HYDRAULIC DRIVING EXCEPT THAT NO HYDRAULIC DRIVING WILL BE PERMITTED UNDER ASPHALTIC CONCRETE PAVEMENT.
  - WHERE CUTTING OR BREAKING OF EXISTING PAVEMENT IS NECESSARY, SECURE PERMISSION FROM THE OWNER BEFORE CUTTING OR BREAKING THE PAVEMENT AND THEN MAKE ALL NECESSARY REPAIRS AND REPLACEMENTS TO THE APPROVAL OF THE OWNER AND AT NO ADDITIONAL COST TO THE OWNER.
- C. **INSPECTION OF PIPE AND FITTINGS** - CAREFULLY INSPECT ALL PIPE AND FITTINGS BEFORE INSTALLATION, REMOVING ALL DIRT, SCALE, AND BURRS AND REAMING AS REQUIRED; INSTALL ALL PIPE WITH ALL MARKINGS UP FOR VISUAL INSPECTION AND VERIFICATION.
- D. **PVC PIPE**
- PVC PIPE SHALL BE INSTALLED IN A MANNER WHICH WILL PROVIDE FOR EXPANSION AND CONTRACTION AS RECOMMENDED BY THE PIPE MANUFACTURER. ROUTING IS DIAGRAMMATIC AND SHALL BE INSTALLED IN SUCH A MANNER AS TO CONFORM WITH THE DETAILS PER THE DRAWINGS.
  - IN JOINING, USE ONLY THE SPECIFIED OR MANUFACTURER'S RECOMMENDED SOLVENT AND MAKE ALL JOINTS IN STRICT ACCORDANCE WITH THE MANUFACTURER'S RECOMMENDED METHODS; GIVE SOLVENT WELDS AT LEAST 15 MINUTES SET UP TIME BEFORE MOVING OR HANDLING AND 24 HOURS CURING TIME BEFORE FILLING WITH WATER.
18. INSTALLATION OF EQUIPMENT
- A. **AUTOMATIC CONTROLLER LOCATION AND INSTALLATION**
- AUTOMATIC CONTROLLER(S) SHALL BE INSTALLED AT THE LOCATION(S) SHOWN ON THE DRAWINGS.
  - THE CONTROLLER LOCATION IS ESSENTIALLY DIAGRAMMATIC AND SHALL BE SPECIFICALLY LOCATED BY THE OWNER OR HIS REPRESENTATIVE.
  - ALL LOCAL AND APPLICABLE CODES SHALL TAKE PRECEDENCE IN THE FURNISHING AND/OR CONNECTING OF 110V ELECTRICAL SERVICE TO THE CONTROLLER.
  - ADEQUATE COVERAGE (18" MINIMUM) OF THE 24V SERVICE WIRE LEADING FROM THE CONTROLLER SHALL BE INSTALLED FROM THE BOTTOM OF THE CONTROLLER TO TRENCHES.
  - CONTROLLERS SHALL BE INSTALLED WITHIN VANDAL-RESISTANT ENCLOSURES AS CALLED FOR ON THE DRAWINGS.
- B. **CONTROL WIRES**
- ALL ELECTRICAL EQUIPMENT AND WIRING SHALL COMPLY WITH LOCAL AND STATE CODES AND BE INSTALLED BY THOSE SKILLED AND IN THE TRADE. UNLESS THE GOVERNING CODE SPECIFIES OTHERWISE, LOW VOLTAGE CONTROL WIRE MAY BE INSTALLED BY THE IRRIGATION CONTRACTOR.
  - CONNECTING AND SPLICING OF WIRE AT THE VALVES SHALL BE MADE USING DURA SEAL CRIMP SPLICES AS MANUFACTURED BY RAYCHEM CORPORATION. CONTRACTOR SHALL REFER TO RAYCHEM INSTALLATION PROCEDURES USING THE ULTRATORCH 3 HEATING TOOL. NO OTHER SPLICES WILL BE ALLOWED.
- C. **COMMUNICATION CABLE**
- COMMUNICATION CABLE SHALL BE INSTALLED FROM THE FIELD CONTROL UNIT TO THE AREA CALLED FOR ON THE PLANS.
  - INSTALL CABLE IN PVC CONDUIT AND STUB IN VALVE BOX AS INDICATED ON THE PLANS. ENDS OF CABLE SHALL BE SEALED WITH AN APPROVED WATER TIGHT CONNECTORS AS SPECIFIED. (SEE SECTION 18-B-2 ABOVE).
  - FIELD SPLICES ARE NOT PERMITTED, EXCEPT WHERE TYING IN TO CABLE WHICH HAS BEEN STUBBED OUT BY OTHERS. SPLICES SHALL BE MADE USING A PARGE SPLICE KIT NO. P716ZD-1 AND IN ACCORDANCE WITH THE MANUFACTURER'S RECOMMENDATIONS.
  - INSTALL ALL COMMUNICATION CABLE IN APPROVED PVC ELECTRICAL CONDUIT.
- D. **ELECTRICAL WORK** - ALL ELECTRICAL WORK SHALL BE INSTALLED PER CODE REQUIREMENTS.
- E. **QUICK COUPLING VALVES** - QUICK COUPLING VALVES SHALL BE SET APPROXIMATELY 12" FROM WALKS, CURBS, HEADER BOARDS, OR PAVED AREAS WHERE APPLICABLE PER DETAIL DRAWINGS.
- F. **VALVES**
- ALL VALVES SHALL BE INSTALLED AS SHOWN IN THE DETAILS AND IN ACCORDANCE WITH MANUFACTURER'S RECOMMENDATIONS.
  - ALL AUTOMATIC VALVES SHALL BE SIZED AS SHOWN ON PLANS. GATE VALVES SHALL BE LINE SIZE.
  - INSTALL EACH CONTROL VALVE IN A SEPARATE VALVE BOX WITH A MINIMUM OF 12" BETWEEN VALVES AND 6" FROM ANY WALK OR STRUCTURE.
- G. **VALVE BOXES**
- VALVE BOXES INSTALLED NEAR WALKS, CURBS, HEADER BOARDS AND PAVING SHALL ABUT THOSE ITEMS AND THE TOP SURFACES SHALL BE FLUSH WITH ITEMS LISTED ABOVE.
  - ALL VALVE BOXES SHALL BE INSTALLED AS SHOWN IN THE DETAILS IN ACCORDANCE WITH MANUFACTURER'S RECOMMENDATIONS.
19. TESTING AND INSPECTION
- A. **GENERAL**
- FURNISH ALL NECESSARY TESTING EQUIPMENT AND PERSONNEL.
  - CORRECT ALL LEAKS AND RETEST UNTIL ACCEPTANCE BY THE OWNER.
- B. **COVERING UP UNINSPECTED WORK** - DO NOT ALLOW OR CAUSE ANY OF THE WORK OF THIS SECTION TO BE COVERED UP OR ENCLOSED UNTIL IT HAS BEEN INSPECTED, TESTED AND APPROVED BY THE OWNER AND AUTHORIZED AGENCIES. (SEE SECTION 4-D-2)

- C. **FLUSHING** - BEFORE BACKFILLING THE MAIN LINE, AND WITH ALL CONTROL VALVES IN PLACE BUT BEFORE LATERAL PIPES ARE CONNECTED, COMPLETELY FLUSH AND TEST THE MAIN LINE AND REPAIR ALL LEAKS; FLUSH OUT EACH SECTION OF LATERAL PIPE BEFORE IRRIGATION HEADS ARE ATTACHED.
- D. **TESTING**
- MAKE ALL NECESSARY PROVISIONS FOR THOROUGHLY BLEEDING THE LINE OF AIR AND DEBRIS.
  - BEFORE TESTING, FILL THE LINE WITH WATER FOR A PERIOD OF AT LEAST 24 HOURS.
  - PRIOR TO INSTALLATION OF CONTROL VALVES, TEST ALL LIVE WATER LINES FOR LEAKS AT A PRESSURE OF 150 PSI FOR A PERIOD OF TWO HOURS, WITH ALL COUPLINGS EXPOSED AND WITH ALL PIPE SECTIONS CENTER LOADED.
  - ADJUST REMOTE CONTROL VALVES SO THAT THE MOST REMOTE SPRINKLER HEADS OPERATE AT THE PRESSURE RECOMMENDED BY THE HEAD MANUFACTURER. ADJUST REMOTE CONTROL VALVES SO A UNIFORM DISTRIBUTION OF WATER IS APPLIED BY THE SPRINKLER HEADS TO THE PLANTING AREA FOR EACH INDIVIDUAL VALVE SYSTEM.
- E. **FINAL INSPECTION**
- THOROUGHLY CLEAN, ADJUST AND BALANCE ALL SYSTEMS.
  - DEMONSTRATE THE ENTIRE SYSTEM TO THE OWNER, HIS AUTHORIZED AGENT AND/OR GOVERNING AGENCIES TO SHOW THAT ALL REMOTE CONTROL VALVES ARE PROPERLY BALANCED, ALL HEADS ARE PROPERLY ADJUSTED FOR RADIUS AND ARC OF COVERAGE, AND THAT THE INSTALLED SYSTEM IS WORKABLE, CLEAN AND EFFICIENT.
20. OPERATIONAL AND MATERIALS MANUALS
- A. **OPERATIONAL AND PRODUCT MANUALS** - PREPARE AND DELIVER TO THE OWNER, PRIOR TO APPROVED FINAL INSPECTION, ALL REQUIRED AND NECESSARY DESCRIPTIVE MATERIAL IN COMPLETE DETAIL AND SUFFICIENT QUANTITY, OPERATION AND PRODUCT MANUAL. THE MANUAL SHALL DESCRIBE THE MATERIAL INSTALLED AND SHALL BE IN SUFFICIENT DETAIL TO PERMIT OPERATING PERSONNEL TO UNDERSTAND, OPERATE AND MAINTAIN ALL EQUIPMENT. SPARE PARTS LISTS AND RELATED MANUFACTURER INFORMATION SHALL BE INCLUDED FOR EACH EQUIPMENT ITEM INSTALLED.
- B. EACH COMPLETE, BOUND MANUAL SHALL INCLUDE THE FOLLOWING INFORMATION:
- INDEX SHEET STATING CONTRACTOR'S ADDRESS AND TELEPHONE NUMBER.
  - DURATION OF GUARANTEE PERIOD.
  - LIST OF EQUIPMENT WITH NAMES AND ADDRESSES OF LOCAL MANUFACTURER REPRESENTATIVES.
  - COMPLETE OPERATING AND MAINTENANCE INSTRUCTIONS ON ALL MAJOR EQUIPMENT.
- C. IN ADDITION TO THE ABOVE MANUALS, PROVIDE THE MAINTENANCE PERSONNEL WITH INSTRUCTIONS FOR MAJOR EQUIPMENT AND SHOW WRITTEN EVIDENCE TO THE OWNER, AT THE CONCLUSION OF THE PROJECT, THAT THIS SERVICE HAS BEEN RENDERED.
- D. **INSPECTION**
- AT ALL TIMES PERMIT THE OWNER OR HIS AUTHORIZED AGENTS TO VISIT AND OBSERVE THE WORK OR ANY PART THEREOF. MAINTAIN PROPER FACILITIES AND PROVIDE SAFE ACCESS FOR SUCH OBSERVATIONS TO ALL PARTS OF THE WORK. WHERE THE SPECIFICATIONS REQUIRE WORK TO BE TESTED, IT SHALL NOT BE COVERED UP UNTIL TESTED OR APPROVED BY THE OWNER AND GOVERNING AGENCIES. THE CONTRACTOR SHALL BE SOLELY RESPONSIBLE FOR NOTIFYING THE OWNER AND REQUIRED AGENCY (48 HOUR NOTICE MINIMUM REQUIRED), WHERE AND WHEN SUCH WORK IS IN READINESS FOR TESTING. SHOULD ANY SUCH WORK BE COVERED WITHOUT SUCH TEST OR APPROVAL, IT SHALL, IF SO ORDERED, BE UNCOVERED AT THE CONTRACTOR'S EXPENSE.
  - OBSERVATION REQUIRED
    - PRESTART MEETING
    - LAYOUT OF CONTROL EQUIPMENT AND HEADS
    - MAIN LINE PRESSURE TEST AND TRENCH DEPTH CHECK.
    - LATERAL TRENCH DEPTH CHECK
    - COVERAGE TEST AND PREFINAL OBSERVATION
    - FINAL OBSERVATION
- E. **STANDARD OF INSTALLATION** - MATERIAL AND WORKMANSHIP SHALL BE IN ACCORDANCE WITH LOCAL CODES AND ORDINANCES OF LEGALLY CONSTITUTED AUTHORITIES, EXCEPT THAT WHERE PROVISIONS OF THESE SPECIFICATIONS EXCEED SUCH REQUIREMENTS, THESE SPECIFICATIONS SHALL GOVERN.
- F. **PRESERVATION AND CLEANING** - CLEANUP ALL WORK AS IT PROGRESSES. AT FREQUENT INTERVALS, AND AT ALL TIMES WHEN DIRECTED BY THE OWNER, REMOVE AND DISPOSE OF ACCUMULATIONS OF RUBBISH AND DEBRIS OF ALL KINDS. AT THE TIME OF COMPLETION, THE ENTIRE SITE SHALL BE CLEARED OF TOOLS, EQUIPMENT, RUBBISH, ETC., ALL OF WHICH SHALL BE LEFT IN PROPER, CLEAN CONDITION READY FOR ACCEPTANCE.
- G. **COMPLETION** - THE WORK SHALL BE ACCEPTED IN WRITING WHEN THE ENTIRE SCOPE OF WORK HAS BEEN COMPLETED SATISFACTORILY TO THE OWNER. IN JUDGING THE WORK, NO ALLOWANCE FOR DEVIATION FROM THE ORIGINAL PLANS AND SPECIFICATIONS WILL BE MADE UNLESS PREVIOUSLY APPROVED BY THE OWNER
- H. **EQUIPMENT** - IRRIGATION EQUIPMENT, OPERATING KEYS AND SPARE PARTS SHALL BE FURNISHED TO THE OWNER AS SHOWN ON THE PLANS.
- I. **SERVICE BY THE CONTRACTOR** - THE CONTRACTOR SHALL SERVICE THE SYSTEM AS THE OWNER'S REQUEST DURING THE GUARANTEE PERIOD AND SHALL BE PAID FOR WORK PERFORMED WHICH IS NOT COVERED BY THE GUARANTEE. IF REQUESTED BY THE OWNER, THE CONTRACTOR SHALL FURNISH THE OWNER WITH A SCHEDULE OF SERVICES AND FEES.
- J. **FINAL ACCEPTANCE** - WITHIN 10 DAYS OF THE CONTRACTOR'S NOTIFICATION THAT THE INSTALLATION IS COMPLETE, THE OWNER AND REQUIRED AGENCIES WILL OBSERVE THE INSTALLATION AND, IF FINAL ACCEPTANCE IS NOT GIVEN, WILL PREPARE A "PUNCH LIST" WHICH, UPON COMPLETION BY THE CONTRACTOR, AND APPROVED BY THE OWNER, WILL SIGNIFY FINAL ACCEPTANCE BY THE OWNER.

## CITY OF INDUSTRY

APPROVED BY: \_\_\_\_\_  
 CLEMENT N. CALVILLO, PE, REG. 27743 DEPUTY CITY ENGINEER DATE \_\_\_\_\_

SAN JOSE AVENUE RECONSTRUCTION  
 FROM CHARLIE RD. TO NOGALES STREET

## LANDSCAPE SPECIFICATIONS

DESIGNED BY: \_\_\_\_\_ CHECKED BY: \_\_\_\_\_  
 DRAFTED BY: \_\_\_\_\_ DATE: APRIL 12, 2022

JOB NO. CITY - MP 08-09 SHT. 14 OF 14



NO.	DATE	REVISIONS	CK.	BY



**CITY OF INDUSTRY**  
 INCORPORATED JUNE 18, 1957  
 P.O. Box 3366, City of Industry, California 91744  
 Administrative Offices: 15625 Mayor Dave Way  
 (626) 333-2211

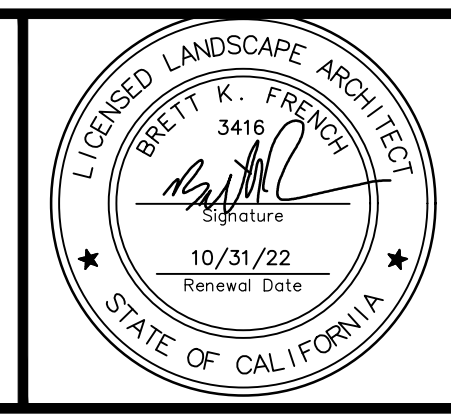

Prepared by: **Environs** LLC  
 LANDSCAPE ARCHITECTURE  
 Creating Sustainable & Water Conserving Solutions  
 801 El Berrero • San Clemente, CA 92672  
 PH. (949) 636-4663

BRETT FRENCH, RLA #3416 DATE: 4-12-22  
 DESIGN BY: BKF DRAWN BY: BKF

# CITY OF INDUSTRY IMPROVEMENT PROJECT NO. 439

## SAN JOSE AVENUE RECONSTRUCTION FROM CHARLIE ROAD TO NOGALES STREET POWER DUCT AND FIBER OPTIC CONDUIT PLAN CONTRACT NO. CITY-1439

### GENERAL NOTES

- UNLESS OTHERWISE NOTED, ALL WORK SHALL BE DONE IN ACCORDANCE WITH THE STANDARD SPECIFICATIONS FOR PUBLIC WORKS CONSTRUCTION, 2024 EDITION WITH ALL CURRENT SUPPLEMENTS, PUBLISHED BY BUILDING NEWS INC., LOCATED AT 900 PARK CENTER DRIVE, SUITE E, VISTA, CA 92081 AND APPROPRIATE STANDARD DRAWINGS.
- PRIOR TO BEGINNING OF ANY WORK, OBTAIN A PERMIT FROM THE CITY OF INDUSTRY, 15625 MAYOR DAVE WAY, CITY OF INDUSTRY, CA 91744, (626) 333-2211, IN ACCORDANCE WITH THE PROJECT SPECIFICATIONS.
- ALL WORK COVERED BY THIS PLAN SHALL BE INSPECTED BY THE CITY ENGINEER. REQUEST FOR INSPECTION SERVICE SHALL BE MADE 48-HOURS IN ADVANCE AT (626) 333-0336.
- STREET IMPROVEMENT CONSTRUCTION SHALL BE DONE ACCORDING TO THE STANDARD PLANS, LATEST EDITION, OF THE CITY OF INDUSTRY, AVAILABLE AT THE OFFICE OF THE CITY ENGINEER AT 15625 MAYOR DAVE WAY, CITY OF INDUSTRY, CA. 91744.
- WORK IN EXISTING STREETS SHALL BE COMPLETED AS SOON AS POSSIBLE TO MINIMIZE INCONVENIENCE TO ADJACENT PROPERTY OWNERS AND THE TRAVELING PUBLIC. FAILURE TO COMPLY WITH THIS REQUIREMENT IS A VIOLATION OF CITY ORDINANCE.
- THE CONTRACTOR SHALL NOTIFY THE LOS ANGELES COUNTY FIRE DEPARTMENT (626) 963-2417 AND THE LOS ANGELES SHERIFF DEPARTMENT (626) 330-3322 AT THE CITY OF INDUSTRY SUBSTATION AT LEAST 48-HOURS PRIOR TO START OF WORK.
- ALL UTILITY TRENCHES IN PUBLIC STREETS OR FUTURE PUBLIC STREETS SHALL BE BACKFILLED WITH A CLEAN GRANULAR MATERIAL HAVING A MINIMUM SAND EQUIVALENT OF 30. BACKFILL SHALL BE COMPACTED TO A MINIMUM RELATIVE DENSITY OF 90 PERCENT, UP TO 6" BELOW FINAL GRADE AND AT LEAST 95% AT UPPER 6" OF FINAL GRADE.
- THE OPTION OF USING SLAG OR CRUSHED MISC. BASE (OMB) IN LIEU OF CRUSHED AGGREGATE BASE FOR ANY STREET IMPROVEMENT IS NOT ALLOWED.
- EXISTING CONCRETE IMPROVEMENTS AND ASPHALT CONCRETE PAVEMENT SHALL BE SAW CUT, FULL DEPTH, TO A TRUE LINE WHERE NEW CONCRETE OR ASPHALT IS TO JOIN.
- ALL MANHOLES SHALL BE ADJUSTED TO FINISHED GRADE IN ACCORDANCE WITH SECTION 403 OF THE STANDARD SPECIFICATIONS. CONTRACTOR SHALL NOTIFY COUNTY SANITATION DISTRICT OF LOS ANGELES COUNTY (CSD), SUPERINTENDENT OF MAINTENANCE AT (213) 774-7272 A MINIMUM OF 48 HOURS PRIOR TO THE COMMENCEMENT OF ANY WORK IN THE AREA OF THEIR MANHOLES. CONTRACTOR SHALL ASSIST IN THE ADJUSTMENT OF MANHOLES IN ACCORDANCE WITH THEIR PROCEDURES, LATEST EDITION.
- THE CONTRACTOR SHALL PROTECT AND RESTORE EXISTING UTILITIES AND IMPROVEMENTS AS PER SECTION 400, 402-1 AND 402-2 OF THE STANDARD SPECIFICATIONS FOR PUBLIC WORKS CONSTRUCTION.
- IT SHALL BE THE RESPONSIBILITY OF THE CONTRACTOR TO LOCATE ALL UTILITIES OF EVERY NATURE WHETHER SHOWN HEREON OR NOT TO PROTECT THEM FROM DAMAGE. THE CONTRACTOR SHALL BEAR THE TOTAL EXPENSE OF REPAIR OR REPLACEMENT OF SAID UTILITIES DAMAGED BY OPERATIONS IN CONNECTION WITH THE PROSECUTION OF THE WORK.
- 48-HOURS PRIOR TO ANY STREET WORK, THE CONTRACTOR SHALL CALL THE UNDERGROUND SERVICE ALERT AT 1 (800) 422-4133 AND OBTAIN AN INQUIRY IDENTIFICATION NUMBER.
- THE FOLLOWING IS A LIST OF THE UTILITY COMPANIES AND THE PERSONS TO CONTACT REGARDING THE RESPECTIVE UTILITIES WITHIN THE LIMITS OF THIS PROJECT:
 

MR. JERRY RUIZ FRONTIER CALIFORNIA, INC.	(909) 649-6369
MR. EDWIN PARK SOUTHERN CALIFORNIA GAS	(714) 634-7260
MR. STEVEN NGUYEN SOUTHERN CALIFORNIA EDISON	(626) 665-5227
MR. KEITH FOUTS ROWLAND WATER DISTRICT	(562) 690-7145
MR. ANTHONY HOWARD SANITATION DISTRICT OF L.A. COUNTY	(562) 908-4288
MR. NICK VINEYARD UPRR	(909) 685-2612
- ANY CONTRACTOR OR SUBCONTRACTOR PERFORMING WORK ON THIS PROJECT SHALL FAMILIARIZE THEMSELVES WITH THE SITE AND SHALL BE SOLELY RESPONSIBLE FOR ANY DAMAGE TO EXISTING FACILITIES RESULTING DIRECTLY OR INDIRECTLY FROM THEIR OPERATIONS, WHETHER OR NOT SUCH FACILITIES ARE SHOWN ON THESE PLAN

### CONSTRUCTION NOTES:

- UNLESS OTHERWISE SPECIFIED ON THE WORKING DRAWING WHICH FORMS A PART OF THE SPECIFICATION, THE CONTRACTOR/DEVELOPER SHALL FURNISH THE FOLLOWING ITEMS AT NO COST TO THE INDUSTRY PUBLIC UTILITY COMMISSION (IPUC). THE ENGINEER HAS ATTEMPTED TO CORRECTLY SHOW ALL EXISTING UTILITIES AND SUBSTRUCTURES IN THE VICINITY OF THE WORK, BUT DOES NOT GUARANTEE THERE ARE NO OTHER SUBSTRUCTURES IN THE AREA. FAILURE OF THE ENGINEER TO SHOW ALL SUBSTRUCTURES IN THEIR CORRECT LOCATION WILL NOT BE A BASIS FOR A CLAIM FOR EXTRA WORK, AND THE CONTRACTOR SHALL BE RESPONSIBLE FOR ALL DAMAGES TO SUBSTRUCTURES WHETHER SHOWN OR NOT.
- CONDUIT:
    - MINIMUM COVER IN STREET OR PARKWAY IS 30" BELOW GUTTER GRADE, UNLESS NOTED OTHERWISE.
    - MINIMUM COVER ON PRIVATE PROPERTY IS 30" BELOW FINISHED GRADE, UNLESS NOTED OTHERWISE.
    - CONTRACTOR IS TO FURNISH AND INSTALL APPROVED CONDUIT TO IPUC SPECIFICATIONS PER (SCE) UGS-100.1, 110 AND 120.
    - FOR THE TYPE OF CONDUIT FOR THIS JOB, SEE (SCE) UGS-110.1.
    - INSTALL ALL RISERS PER (SCE) UGS-160, 161, 162 AND 170.
    - CAP ALL MAINLINE CONDUITS PER (SCE) UGS-148 AND SERVICE CONDUITS PER (SCE) UGS-150.
    - INSTALL BLANK CONDUIT PLUGS IN ALL CONDUITS TERMINATING INTO VAULTS, MANHOLES, P.M.E.'S, S.O.E.'S & ALL CAP LOCATIONS, PER (SCE) UGS-180.1 & UGS-180.2.
    - INSTALL PULL ROPE IN ALL CONDUIT RUNS. PULL ROPE TO BE 1/4" POLYPROPYLENE OR POLYETHYLENE ROPE, BRAIDED OR TWISTED, FOR SPECIFICATIONS, APPROVED MAKES, AND SUPPLIERS, SEE (SCE) UGS-40.
    - ALL CONDUIT MUST BE MANDERELLED WITH THE APPROVED MANDEREL (SCE) UGS-197. MANDERELING SHALL BE WITNESSED BY CITY INSPECTOR.
  - CONDUIT RADIUS REQUIREMENTS:
    - THE MINIMUM RADIUS FOR BENDS ARE:
      - 36" FOR CONDUITS 3" IN DIAMETER OR SMALLER
      - 48" FOR CONDUITS 4" AND 5" IN DIAMETER
      - 60" FOR 6" DIAMETER CONDUIT
    - THE MINIMUM RADIUS FOR ALL SWEEPS OF ALL MAINLINE CONDUITS IS 12'-6" (UNLESS NOTED OTHERWISE).
  - EXCAVATION AND BACKFILL:
    - WORK AREA SHALL BE CLEARED AND ROUGH GRADED TO WITHIN FOUR INCHES OF FINAL GRADE PRIOR TO INSTALLATION OF AGENCY CONDUIT OR STRUCTURES.
    - ALL EXCAVATIONS SHALL BE IN ACCORDANCE WITH THE CALIFORNIA STATE CONSTRUCTION SAFETY ORDERS (WHEN APPLICABLE), AGENCY SPECIFICATIONS, AND LOCAL GOVERNING LOCAL ORDINANCES.
    - EACH TRENCH TO BE A UNIFORM DEPTH BELOW FINAL GRADE PRIOR TO INSTALLATION OF IPUC CONDUIT OR STRUCTURES.
    - BACKFILL SHALL BE PROVIDED BY THE CONTRACTOR FOR ALL EXCAVATIONS AND SHALL INCLUDE CRUSHED ROCK, CONCRETE, AND/OR IMPORTED BACKFILL, WHEN REQUIRED.
    - BACKFILL WITH A MINIMUM OF ONE SACK PER YARD SAND CEMENT SLURRY AROUND AND OVER VAULTS AND MANHOLES PER (SCE) UGS-30.3, PAR. 6.4 AND AROUND P.M.E.'S WITHIN ONE FOOT OF FINISHED GRADE, PER (SCE) UGS-590.1.
    - BACKFILL, PER AGENCY SPECIFICATIONS, SHALL IMMEDIATELY FOLLOW SUBSTRUCTURE INSTALLATION. AT NO TIME SHALL CABLE BE LEFT EXPOSED OVER 24 HOURS.
    - NO ROCKS ARE ALLOWED WITHIN 12 INCHES OF DIRECT BURIED CABLES OR ANY CONDUIT WITHOUT CONCRETE ENCASUREMENT. NATIVE BACKFILL CAPABLE OF PASSING THROUGH A ONE-HALF INCH MESH SCREEN SHALL BE CONSIDERED TO BE "ROCK FREE". IF EXISTING BACKFILL DOES NOT PASS THROUGH A 1/2" SCREEN, PLACE IMPORTED SAND 3" BELOW AND 12" ABOVE AGENCY CABLES. AFTER THIS POINT, NO ROCKS LARGER THAN 12" DIAMETER ARE PERMITTED.
    - ALL BACKFILL SHALL BE COMPACTED TO MEET OR EXCEED LOCAL ORDINANCES OR OTHER REQUIREMENTS. IT SHALL BE PLACED IN A MANNER THAT WILL NOT DAMAGE THE CONDUIT OR SUBSTRUCTURE OR ALLOW FUTURE SUBSIDENCE OF THE TRENCH OR STRUCTURES.
    - UTILITY TRENCHES IN PUBLIC STREETS SHALL BE BACKFILLED WITH A CLEAN GRANULAR MATERIAL HAVING A MINIMUM SAND EQUIVALENT OF 30. BACKFILL SHALL BE COMPACTED TO A MINIMUM RELATIVE DENSITY OF 90%.
    - ALL CONDUIT ENCASUREMENT SHALL BE 2.02 SACK "EDISON MIX" (MIX CODE S20540). CONTRACTOR TO SPINKLE RED OXIDE ON THE TOP OF ENCASUREMENT.
    - ALL HV UNDERGROUND DUCT PACKAGES SHALL HAVE A TRACING WIRE AND WARNING TAPE MARKERS.
  - PAVING:
    - REPAVING, WHERE REQUIRED, SHALL BE PLACED IN SUCH A MANNER THAT INTERFERENCE WITH TRAFFIC, INCLUDING PEDESTRIAN TRAFFIC, WILL BE KEPT TO A MINIMUM. THE CONTRACTOR SHALL ESTABLISH A PROGRAM OF REPAVING ACCEPTABLE TO THE MUNICIPALITY, COUNTY, OR OTHER AUTHORITY HAVING JURISDICTION AND WHICH IS ACCEPTABLE TO AGENCY.
  - STRUCTURES:
    - ALL SUBSTRUCTURES SHALL BE CONSTRUCTED OR INSTALLED TO IPUC SPECIFICATIONS.
    - INSTALL PROTECTION BARRIERS PER (SCE) UGS-830 WHEN REQUIRED IN AREAS EXPOSED TO TRAFFIC, PER IPUC INSPECTOR.
    - ALL CONDUIT LINES AND CONCRETE FLOORED SUBSTRUCTURES SHALL BE WATER TIGHT.
    - ALL GROUNDING MATERIALS SHALL BE FURNISHED AND INSTALLED BY THE CONTRACTOR.
  - RETAINING WALLS:
    - WHEN REQUIRED, RETAINING WALLS SHALL BE PROVIDED BY THE CONTRACTOR. WALLS ARE REQUIRED WHEREVER GRADE RISES MORE THAN 18 INCHES ABOVE THE STRUCTURE OR 24" ABOVE THE PAD SURFACE AT A DISTANCE OF 5 FEET FROM THE SAME, OR IN AREAS SUBJECT TO EROSION. DESIGN AND INSTALLATION MUST COMPLY WITH LOCAL BUILDING ORDINANCES. REFER TO AGENCY INSPECTOR FOR TYPICAL SPACE REQUIREMENTS.
  - PERMITS:
    - ALL PERMITS NECESSARY FOR EXCAVATION SHALL BE PROVIDED BY THE CONTRACTOR.
  - ACCESS:
    - HEAVY TRUCK ACCESS SHALL BE MAINTAINED TO EQUIPMENT LOCATIONS. STRUCTURES MUST BE CLEAR OF ALL APPURTENANCES THAT WOULD OBSTRUCT THE LOADING OR UNLOADING OF EQUIPMENT.
  - SERVICES:
    - METERS AND SERVICES SHALL COMPLY WITH AGENCY SERVICES REQUIREMENTS.
    - WIRING MUST BE IN ACCORDANCE WITH APPLICABLE LOCAL ORDINANCES AND APPROVED BY LOCAL INSPECTION AUTHORITIES.
  - LOCATION:
    - THE LOCATION OF EXCAVATIONS AND STRUCTURES FOR AGENCY SHALL BE AS SHOWN ON THE WORKING DRAWING. NO DEVIATION FROM THE PLANNED LOCATIONS WILL BE PERMITTED UNLESS APPROVED BY THE IPUC INSPECTOR.
    - ACTUAL LOCATION OF OBSTRUCTIONS, STORM DRAINS, AND/OR OTHER FOREIGN UTILITIES TO BE THE RESPONSIBILITY OF THE CONTRACTOR.
  - CONTRACTOR IS TO VERIFY LOCATION AND WIDTHS OF ALL SIDEWALKS AND DRIVEWAYS PRIOR TO STREET LIGHT INSTALLATION, WITH THE APPROVED STREET IMPROVEMENT PLANS, APPROVED STREET LIGHT PLANS AND THE ACTUAL FIELD CONDITIONS.
  - SURVEY:
    - SURVEYING OF STREET IMPROVEMENTS, PROPERTY CORNERS, LOT LINES, FINISHED GRADE, ETC., NECESSARY FOR THE INSTALLATION OF UNDERGROUND FACILITIES MUST BE COMPLETED AND MARKERS OR STAKES PLACED PRIOR TO THE START OF THE INSTALLATION. IN ADDITION, CONTRACTOR SHALL MAINTAIN THE MARKERS DURING THE INSTALLATION AND INSPECTION BY IPUC. GRADE AND PROPERTY LINE STAKES MUST SHOW ANY OFFSET MEASUREMENTS.
  - COORDINATION AND SUPERVISION:
    - THE CONTRACTOR SHALL PROVIDE SUPERVISION OVER AND COORDINATION AMONG THE VARIOUS CONTRACTORS WORKING WITHIN THE DEVELOPMENT IN ORDER TO PREVENT DAMAGE TO AGENCY FACILITIES. HE IS RESPONSIBLE FOR THE COST OF REPAIRS, REPLACEMENT, RELOCATION, OR OTHER CORRECTIONS TO IPUC FACILITIES MADE NECESSARY BY HIS FAILURE TO PROVIDE SUPERVISION OR TO OTHERWISE COMPLY WITH THESE SPECIFICATIONS.
  - TELEPHONE AND OTHER UTILITY REQUIREMENTS:
    - THE DRAWING PREPARED FOR THIS JOB MAY ALSO COVER THE FACILITIES TO BE INSTALLED FOR THE TELEPHONE COMPANY AND/OR OTHER UTILITY. ANY QUESTIONS CONCERNING DETAILS OF THEIR INSTALLATION SHOULD BE REFERRED TO THE COMPANY CONCERNED.
  - WARRANTY:
    - CONTRACTOR EXPRESSLY REPRESENT AND WARRANT THAT ALL WORK PERFORMED AND ALL MATERIAL USED IN MEETING CONTRACTOR'S OBLIGATIONS HEREIN ARE FREE FROM DEFECTS IN WORKMANSHIP AND ARE IN CONFORMITY WITH IPUC REQUIREMENTS. THIS WARRANTY SHALL COMMENCE UPON RECEIPT BY CONTRACTOR OF IPUC'S FINAL ACCEPTANCE AND SHALL EXPIRE ONE YEAR FROM THAT DATE. CONTRACTOR AGREES TO PROMPTLY CORRECT TO THE AGENCY'S SATISFACTION AND THAT OF ANY GOVERNMENTAL AGENCY HAVING JURISDICTION AND AT CONTRACTOR'S EXPENSE ANY BREACH OF THIS WARRANTY WHICH MAY BECOME APPARENT THROUGH INSPECTION OR OPERATION OF UNDERGROUND ELECTRIC SYSTEM BY IPUC DURING THIS WARRANTY PERIOD.
  - INSPECTION:
    - INSPECTION IS REQUIRED DURING THE CONSTRUCTION PERIOD. A 48 HOUR ADVANCE NOTICE OF INTENT TO START CONSTRUCTION IS REQUIRED FROM THE CONTRACTOR TO THE INDUSTRY URBAN DEVELOPMENT IPUC. PHONE: (626)333-0336

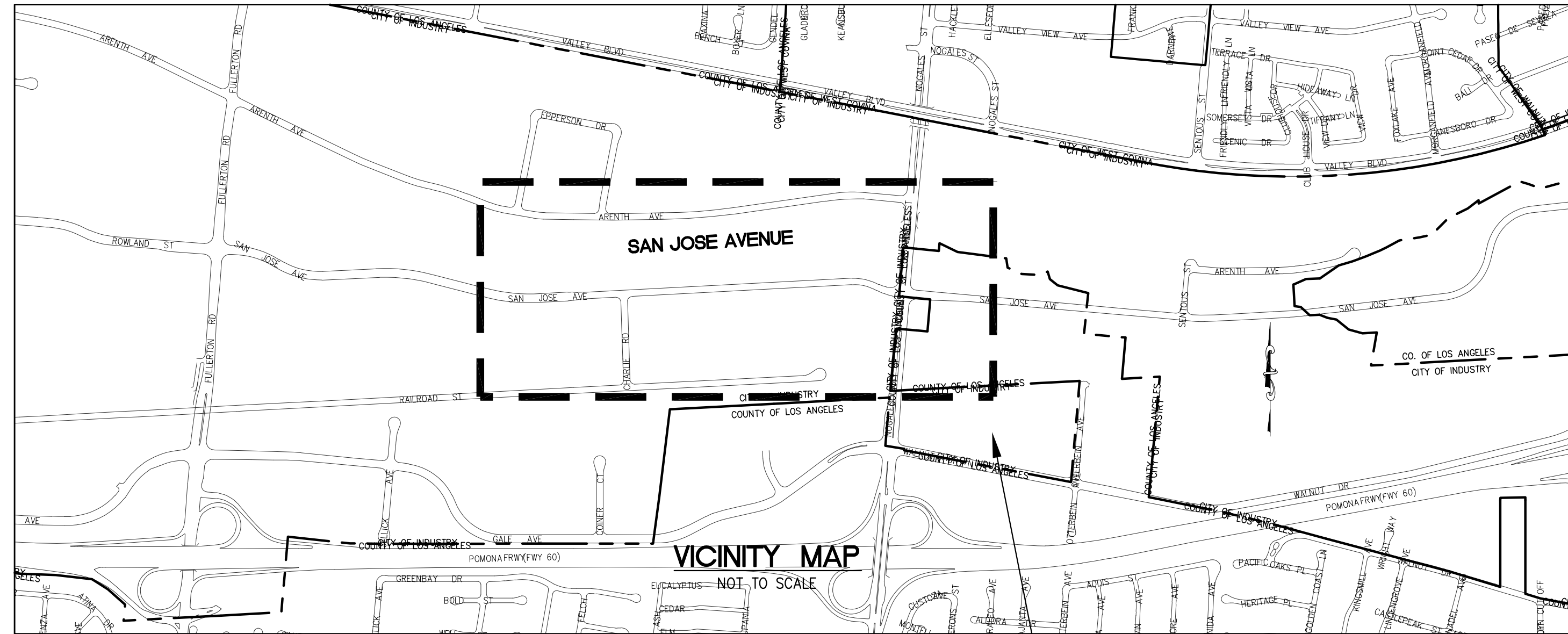

### INDEX OF DRAWINGS

SHEET NO.	DESCRIPTION
1 OF 3	TITLE SHEET: VICINITY MAP, GENERAL NOTES, CONSTRUCTION NOTES, INDEX OF DRAWINGS, NOTICE TO CONTRACTOR
2 OF 3	POWER DUCT AND FIBER OPTIC CONDUIT PLAN
3 OF 3	DETAILS OF POWER DUCT AND FIBER OPTIC CONDUIT PLAN

### NOTICE TO CONTRACTOR

APPROVAL OF THIS PLAN BY THE ENGINEER AND CITY ENGINEER DOES NOT CONSTITUTE A REPRESENTATION AS TO THE ACCURACY OF THE LOCATION OF OR THE EXISTENCE OR NON-EXISTENCE OF ANY UNDERGROUND UTILITY PIPE OR STRUCTURE WITHIN THE LIMITS OF THIS PROJECT. THE EXISTENCE AND LOCATION OF ANY UNDERGROUND UTILITY PIPES OR STRUCTURES SHOWN ON THESE PLANS WERE OBTAINED BY A SEARCH OF AVAILABLE RECORDS.



NO.	DATE	REVISIONS	CHK. BY



**CITY OF INDUSTRY**  
 INCORPORATED JUNE 18, 1957  
 P.O. Box 3366, City of Industry, California 91744  
 Administrative Offices: 15625 Mayor Dave Way  
 (626) 333-2211

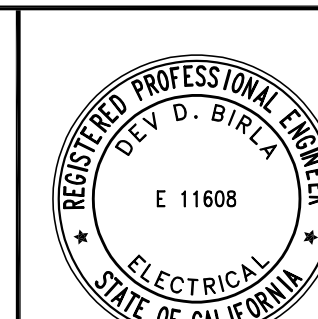

Prepared by:  
**ACNC**  
 ENGINEERING  
 255 N Hacienda Blvd | Ste 222  
 City of Industry | CA | 91744  
 P | 626.333.0336  
 www.cnc-eng.com  
 DEV D. BILRA, P.E. 11608 DATE

## CITY OF INDUSTRY

APPROVED BY: \_\_\_\_\_ DATE: \_\_\_\_\_  
 CLEMENT N. CALVILLO, PE, RCE 27743 CONTRACT DEPUTY CITY ENGINEER      JOSHUA L. NELSON, PE, RCE 66959 CITY MANAGER      DATE: \_\_\_\_\_

**SAN JOSE AVENUE RECONSTRUCTION  
 FROM CHARLIE ROAD TO NOGALES STREET  
 TITLE SHEET: VICINITY MAP, GENERAL NOTES,  
 CONSTRUCTION NOTES, INDEX OF DRAWINGS, NOTICE TO  
 CONTRACTOR**

DESIGNED BY: D.B. CHECKED BY: J.C. JOB NO. MP 08-09  
 DRAFTED BY: W.Y. DATE: MARCH 2025 CONTRACT NO. CITY-1439 SHEET 1 OF 3

CONTRACT DRAWING OF

K:\Misc\0809 San Jose Ave Reconstruction - Railroad Street\Street Lighting Plan - San Jose Ave CNC\Sheet\MP0809 San Jose ST Power Duct 01 TITLE.dwg 4/4/2025 6:06 PM

K:\Misc\0809 San Jose Ave Reconstruction - Railroad Street\Street Lighting Plan- San Jose ST Power Duct Plan 02.dwg  
4/4/2025 5:55 PM

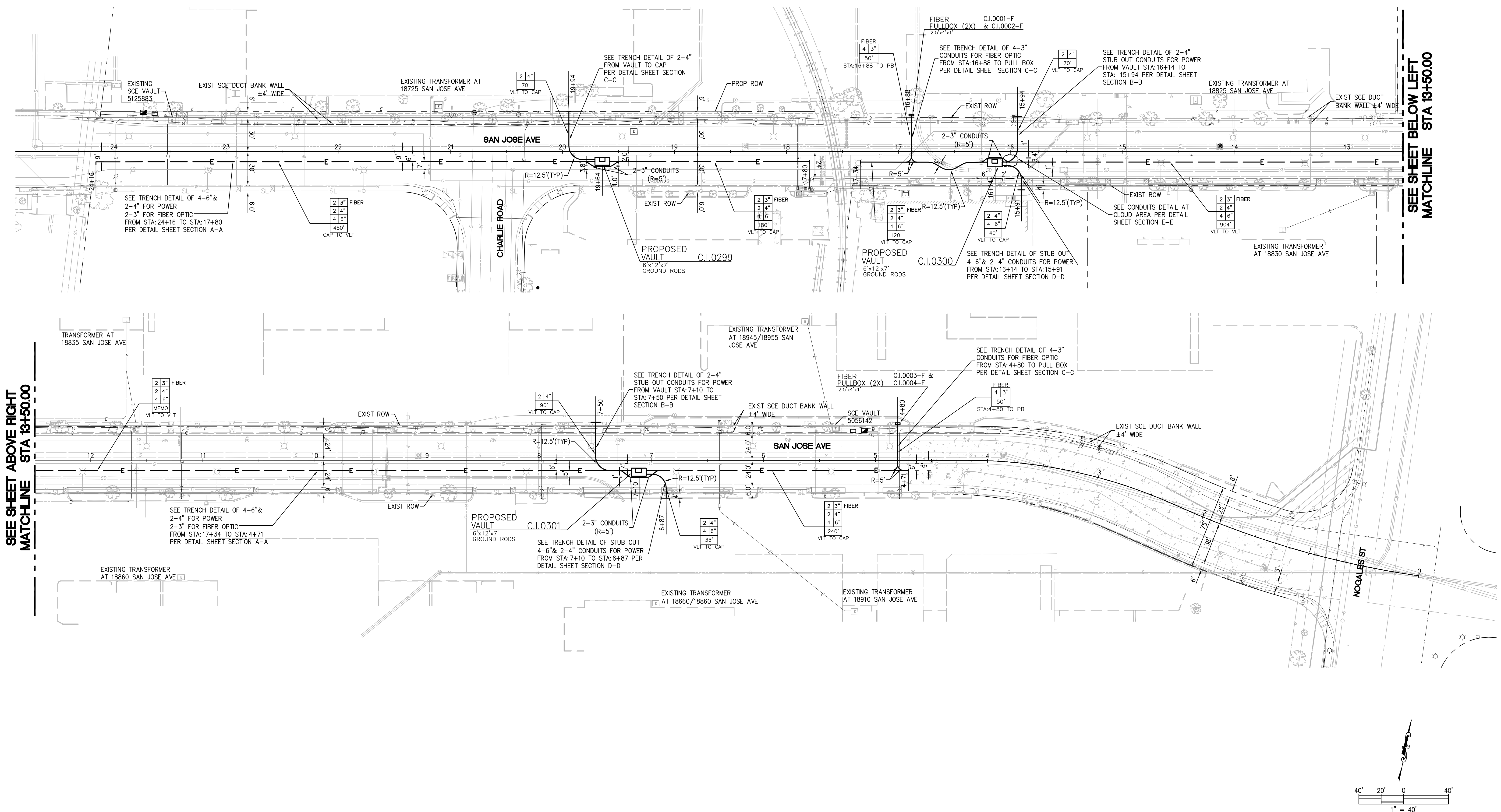

SEE SHEET ABOVE RIGHT  
MATCHLINE STA 13+50.00

SEE SHEET BELOW LEFT  
MATCHLINE STA 13+50.00

NO.	DATE	REVISIONS	CK. BY

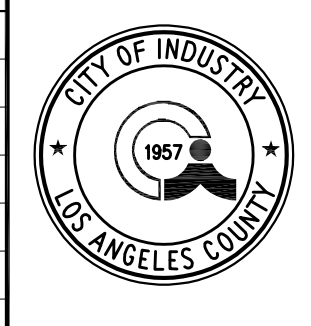

**CITY OF INDUSTRY**  
INCORPORATED JUNE 18, 1957  
P.O. Box 3366, City of Industry, California 91744  
Administrative Offices: 15625 Mayor Dave Way (626) 333-2211

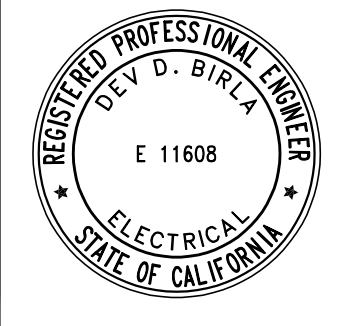

Prepared by:  
**ACNC ENGINEERING**  
255 N Hacienda Blvd | Ste 222  
City of Industry | CA | 91744  
P | 626.333.0336  
www.cnc-eng.com  
DEV D. BILRA, P.E. 11608

<b>CITY OF INDUSTRY</b>			
APPROVED BY:	CLEMENT N. CALVILLO, PE, RCE 27743	CONTRACT DEPUTY CITY ENGINEER	DATE
<b>SAN JOSE AVENUE RECONSTRUCTION FROM CHARLIE ROAD TO NOGALES STREET</b>			
<b>POWER DUCT AND FIBER OPTIC CONDUIT PLAN</b>			
DESIGNED BY:	D.B.	CHECKED BY:	J.C.
DRAFTED BY:	E.C.	DATE:	FEB 2022
JOB NO.	MP 08-09	CONTRACT NO.	CITY-1439
SHEET <b>2</b> OF <b>3</b>		CONTRACT DRAWING OF	

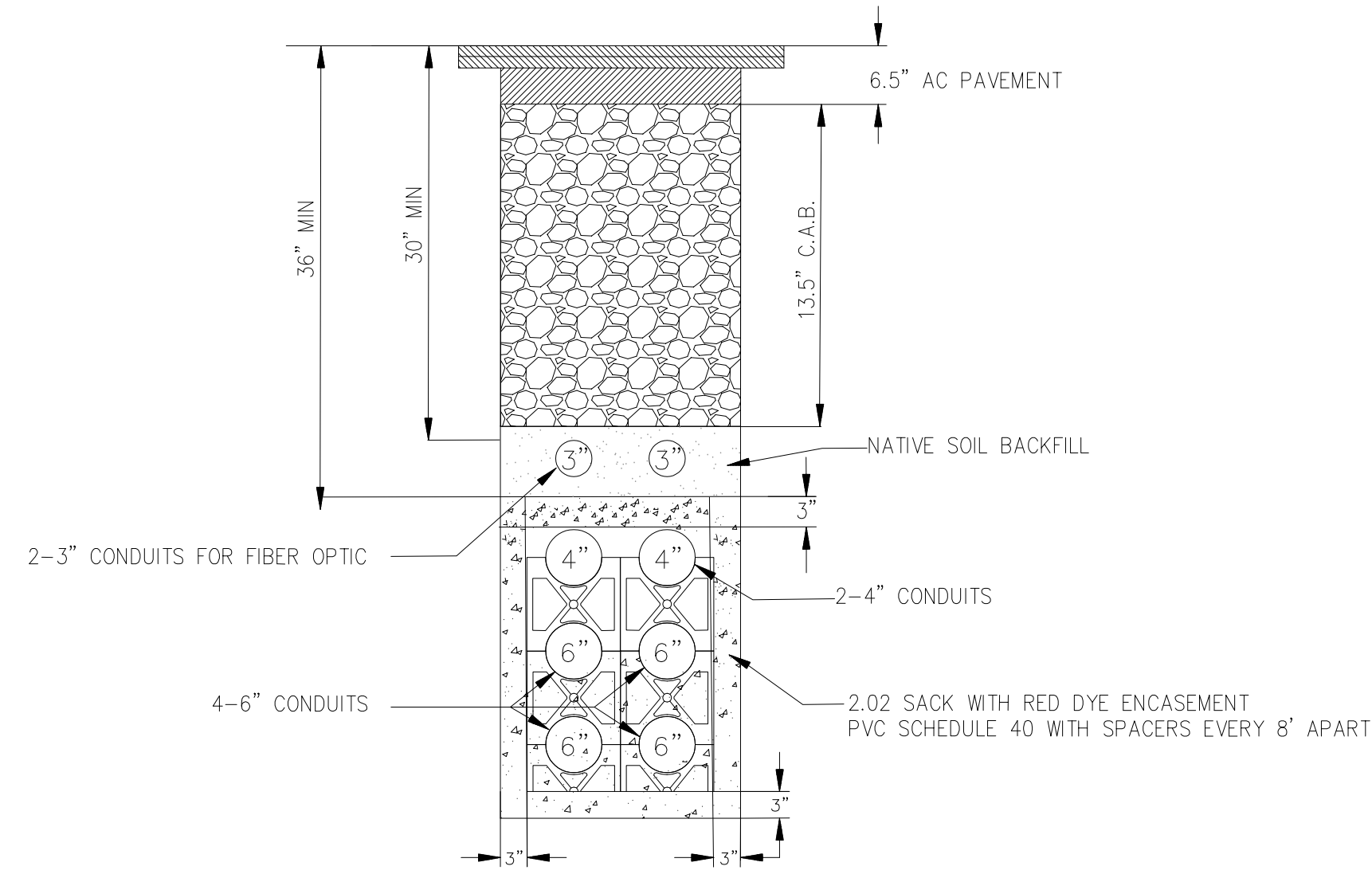

**SECTION A-A: 4-6" & 2-4" IPU ELECTRIC & 2-3" COMMUNICATION TRENCH DETAIL**

NO SCALE

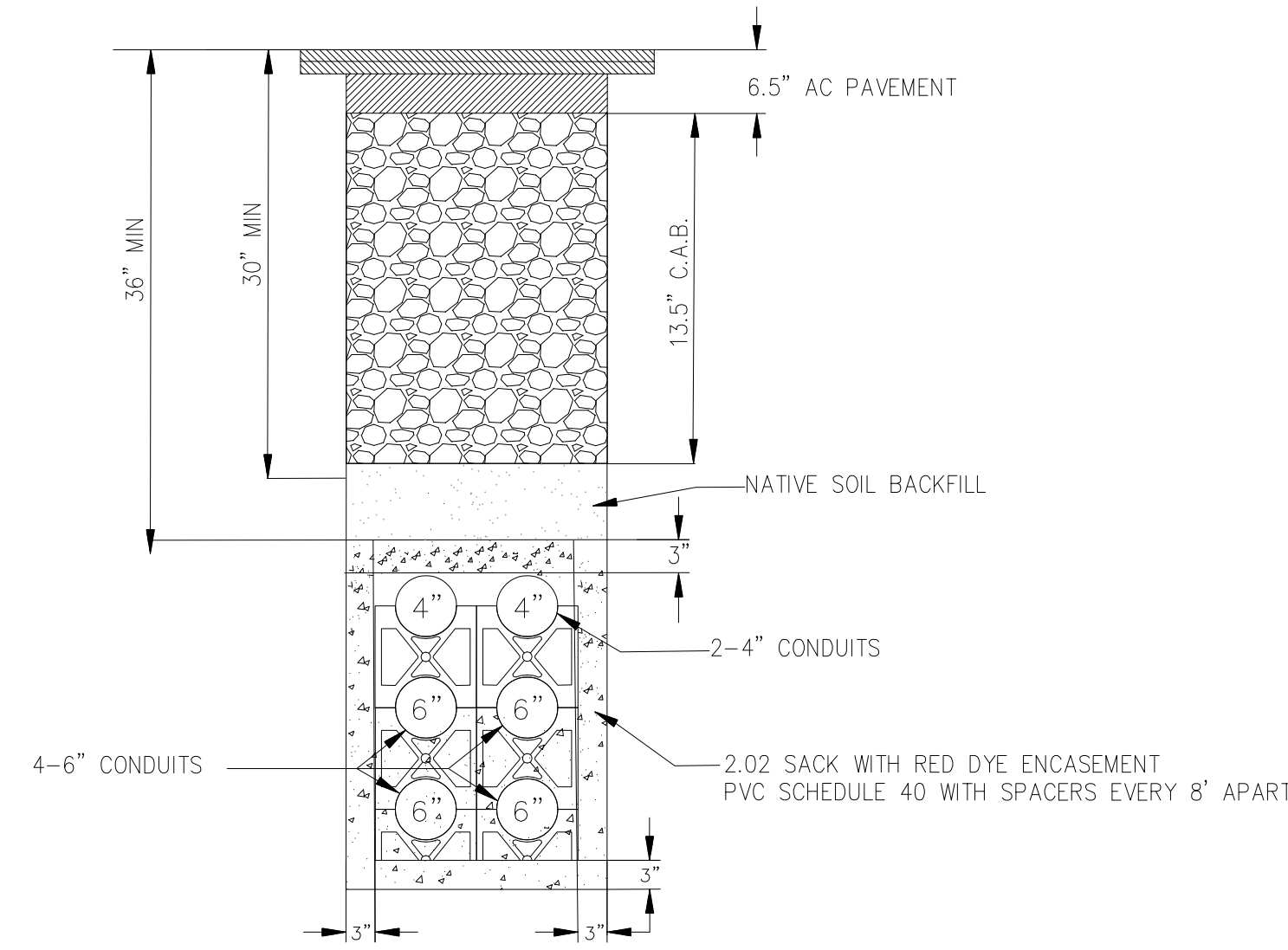

**SECTION D-D: 4-6" & 2-4" IPU ELECTRIC TRENCH DETAIL**

NO SCALE

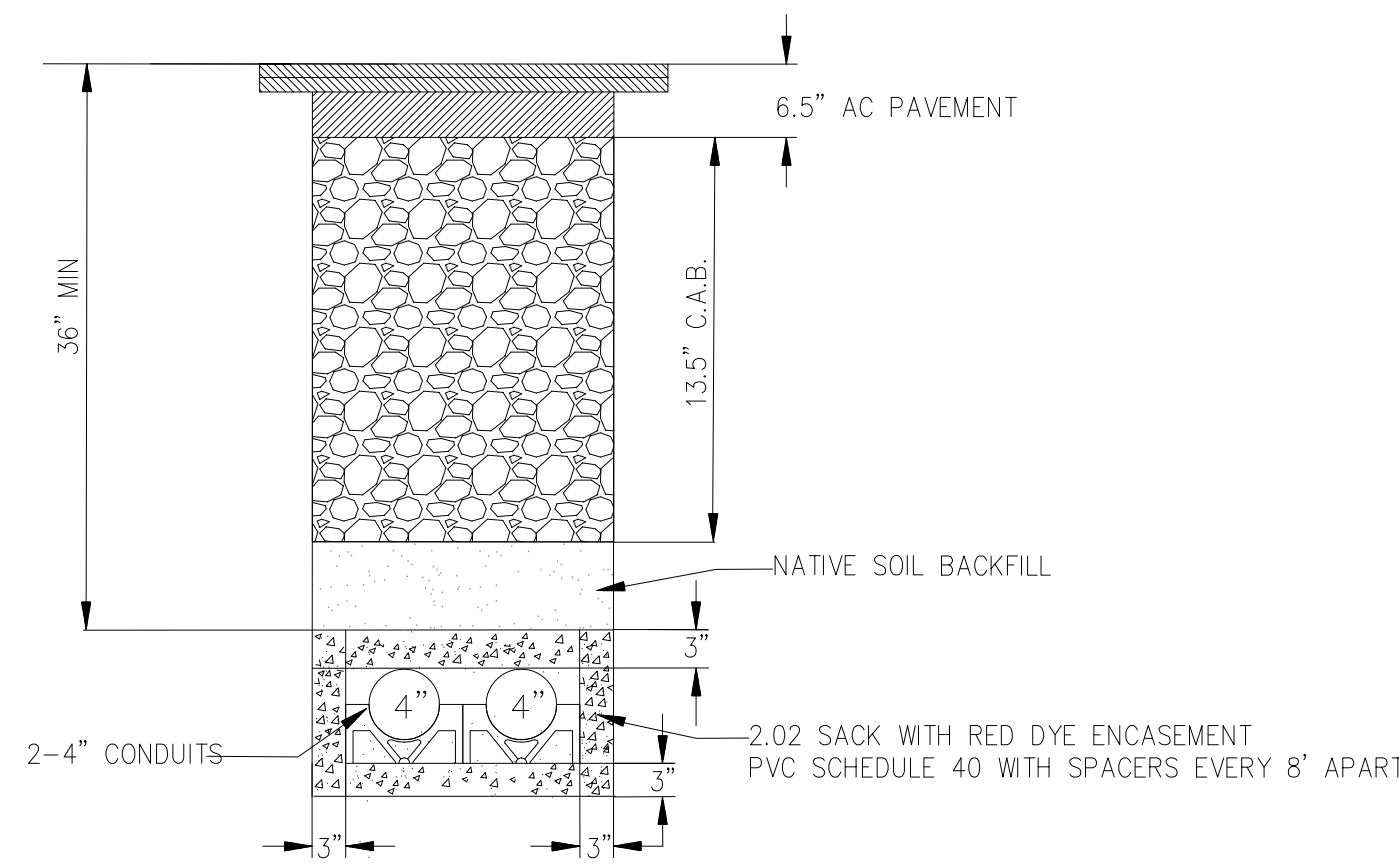

**SECTION B-B: 2-4" IPU ELECTRIC TRENCH DETAIL**

NO SCALE

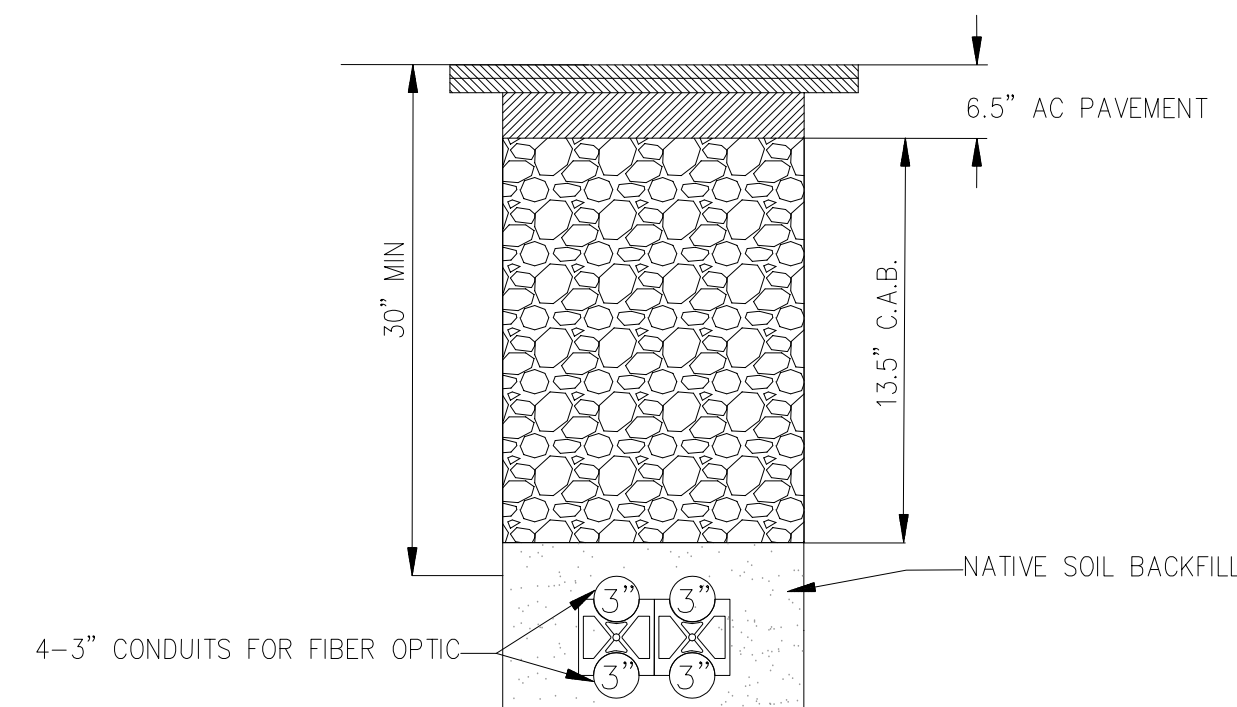

**SECTION C-C: 4-3" COMMUNICATION DUCT DETAIL**

NO SCALE

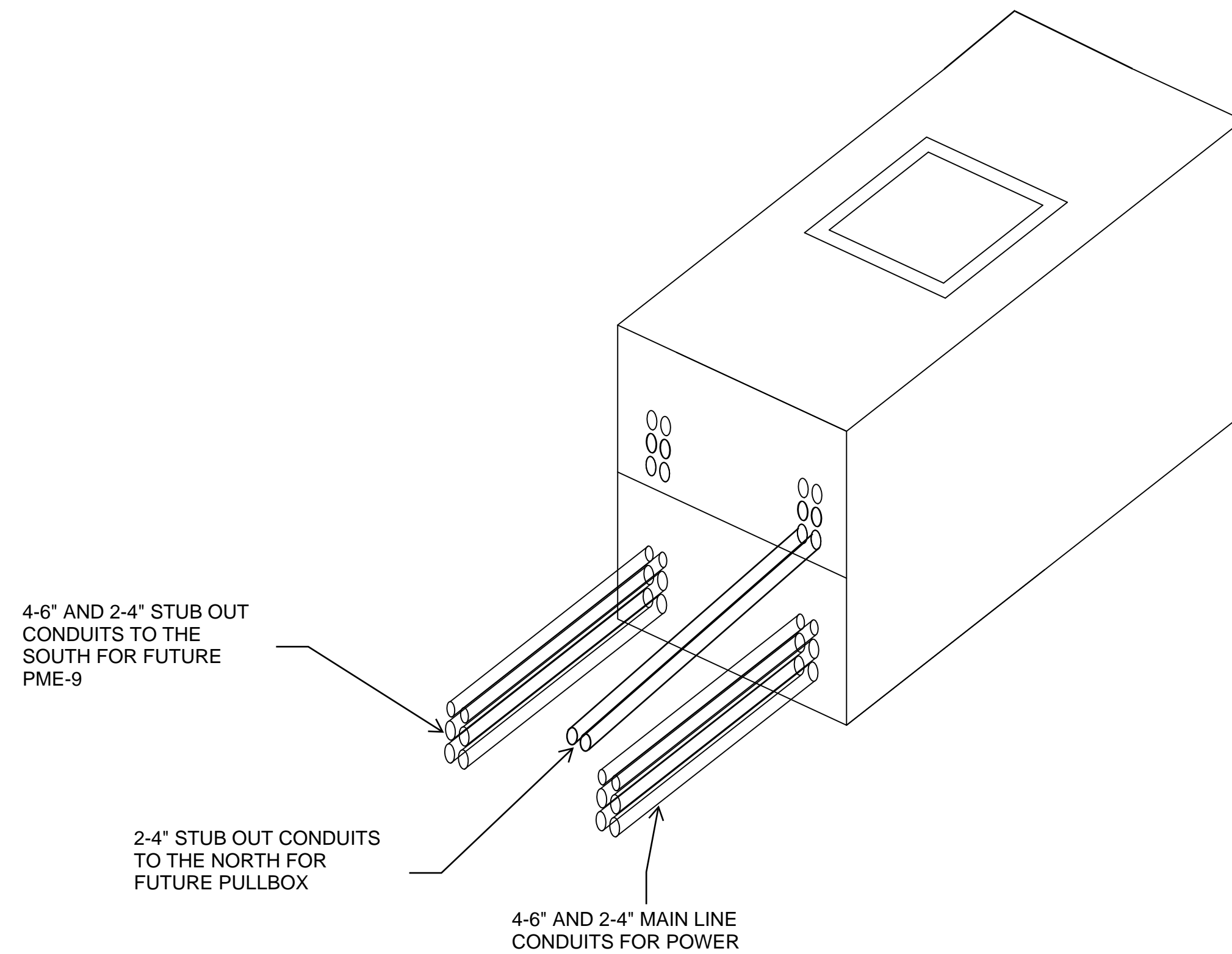
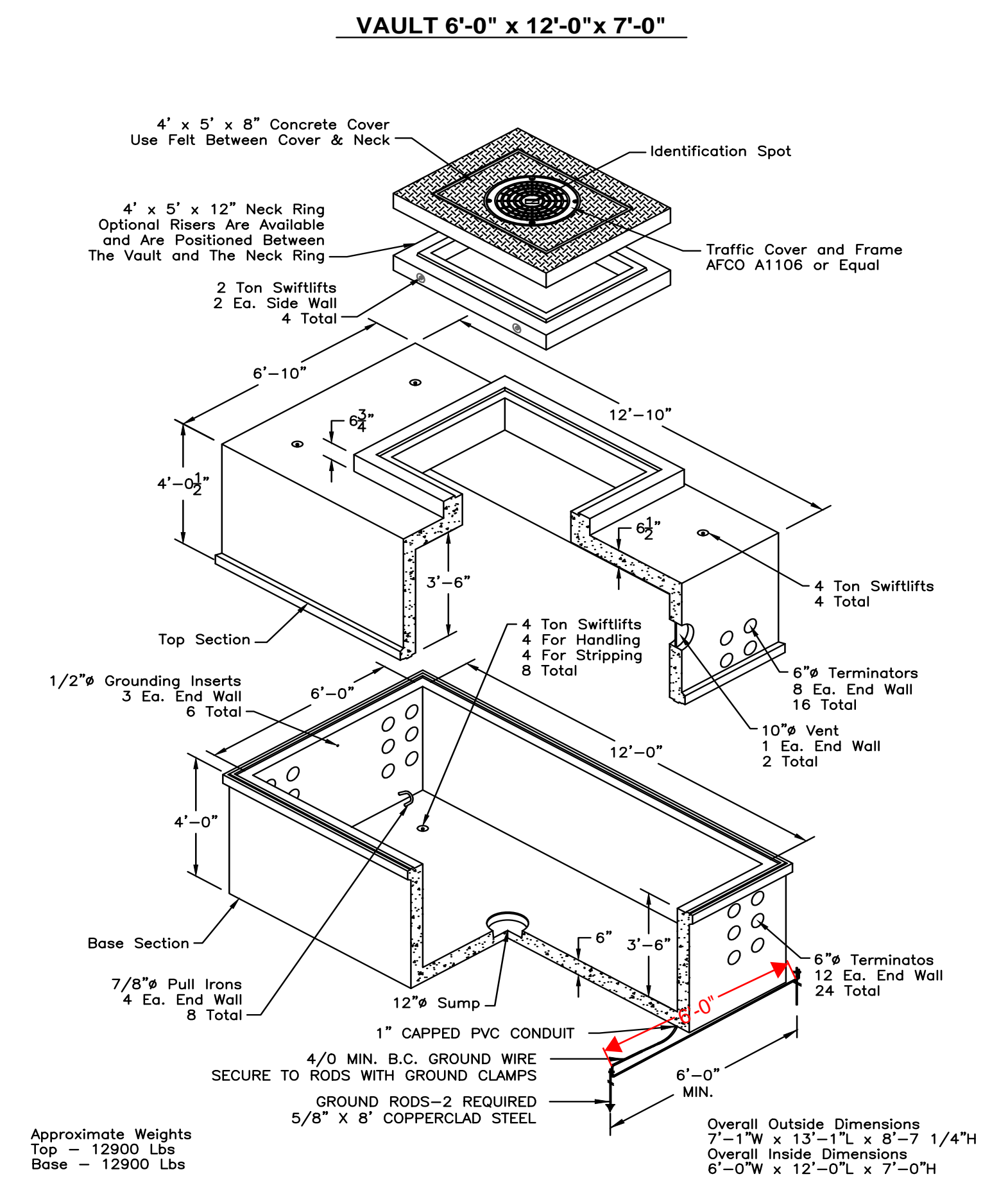

**SECTION E-E**  
NO SCALE

Approximate Weights  
Top - 12900 Lbs  
Base - 12900 Lbs

Overall Outside Dimensions  
7'-1" W x 13'-1" L x 8'-7 1/4" H  
Overall Inside Dimensions  
6'-0" W x 12'-0" L x 7'-0" H

K:\Misc\0809 San Jose Ave Reconstruction - Railroad Street\Street Lighting Plan- San Jose Ave CNC\Sheet\MP0809 San Jose ST Power Duct Plan 03 Detail.dwg 4/3/2025 9:46 AM



NO.	DATE	REVISIONS	CK. BY

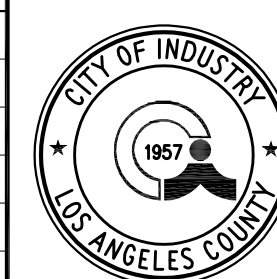

**CITY OF INDUSTRY**

INCORPORATED JUNE 18, 1957  
P.O. Box 3366, City of Industry, California 91744  
Administrative Offices: 15625 Mayor Dave Way  
(626) 333-2211

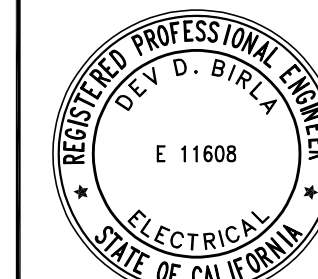

Prepared by:  
**ACNC**  
ENGINEERING

255 N Hacienda Blvd | Ste 222  
City of Industry | CA | 91744  
P | 626.333.0336  
www.cnc-eng.com

DEV D. BILRA, P.E. 11608

DATE

**CITY OF INDUSTRY**

APPROVED BY:

CLEMENT N. CALVILLO, PE, RCE 27743

CONTRACT DEPUTY CITY ENGINEER

DATE

**SAN JOSE AVENUE RECONSTRUCTION  
FROM CHARLIE ROAD TO NOGALES STREET**

**DETAILS OF POWER DUCT AND  
FIBER OPTIC CONDUIT PLAN**

DESIGNED BY: D.B.	CHECKED BY: J.C.	JOB NO. MP 08-09	SHEET 3 OF 3
DRAFTED BY: W.Y.	DATE: MARCH 2025	CONTRACT NO. CITY-1439	

CONTRACT DRAWING OF

ITEM NO. 6.6



# CITY OF INDUSTRY

## MEMORANDUM

**TO:** Honorable Mayor and Members of the City Council

**FROM:** Joshua Nelson, City Manager

**STAFF:** Mathew Hudson, Director of Public Works  
James Cramsie, Sr. Director of Engineering

**DATE:** April 24, 2025

**SUBJECT:** Consideration of Award of Contract No. CITY-1531, Grand Avenue Slope Reconstruction and Pavement Rehabilitation from Baker Parkway to Ferrero Parkway, to Sol Construction, Inc., in an amount not to exceed \$1,876,542.00, and adopt a Notice of Exemption regarding same

---

### **Background:**

On November 14, 2024, the City Council authorized solicitation of public bids for Grand Avenue Slope Reconstruction and Pavement Rehabilitation from Baker Parkway to Ferrero Parkway project for an estimated cost of \$1,860,500.00. This project was bid to procure a contractor to reconstruct an existing roadway slope on the west side of Grand Avenue, north of Baker Parkway. As part of the slope reconstruction, the existing sidewalk, curb and gutter, catch basin will be reconstructed. A portion of the existing street light system will be removed and reinstalled, along with new cabling and service feed connection. As part of this project, the asphalt concrete pavement ("AC") pavement along Grand Avenue between the UPRR bridges will be coldmill and overlaid. There are two (2) approach slabs that will be removed and reconstructed.

On January 15, 2025, the bid was posted in the City's PlanetBids™ vendor portal and an email notification was sent to 741 vendors. The bid was viewed by 95 prospective bidders. The appropriate trade journals were notified on January 15, 2025. The bid was advertised on January 17, 2025, and January 24, 2025, in the San Gabriel Valley Tribune. Questions pertaining to the bid were received up until February 14, 2025, at 5:00 p.m. in the City's Planetbids™ vendor portal.

### **Discussion:**

The bid process closed on March 20, 2025. Nine (9) bids were received. The review of bids has found that Sol Construction, Inc. has submitted the lowest responsive bid and has the relevant experience, qualifications, and licensing necessary to complete this project. Below is a table of

all bidders and their prices.

<b>Bidder</b>	<b>Bid Price</b>
JT Construction Group, Inc.	\$1,690,440.00
Sol Construction, Inc.	\$1,876,542.00
Sully-Miller Contracting Company	\$1,998,483.00
Gentry Brothers, Inc.	\$2,114,325.00
Sequel Contractors, Inc.	\$2,228,227.50
TTS Engineering, Inc.	\$2,547,714.81
Aneen Construction Company, Inc.	\$2,657,244.00
Mike Bubalo Construction Company, Inc.	\$2,895,470.00
Alfaro Communications Construction, Inc.	\$3,317,743.75

After review of all bids, the apparent lowest bidder, JT Construction Group, Inc., submitted subcontractor (Puente Construction Inc.) with a Class B – General Building Contractor to perform concrete work. Staff inquired about the specific work to be performed by Puente Construction and JT responded on April 4, 2025, indicating that Puente’s scope of work included demolition, grubbing and traffic control. Since Puente’s scope of work does not include framing or carpentry, their license does not allow them to perform traffic control work. Therefore, JT’s bid was deemed to be non-responsive.

Sol Construction, Inc., is the lowest responsive bidder and staff recommends an award in an amount of \$1,876,542.00. Additionally, staff recommends that the City Council authorizes the City Manager to approve change orders up to 10 percent of the contract amount.

Staff has determined that this project is subject to review under the California Environmental Quality Act (“CEQA”), however, it falls within the Categorical Exemption, Section 15301 Class 1, minor alteration of existing public facilities. As set forth above, the project involves the maintenance of existing streets by applying slurry seal for pavement preservation, and pursuant to Section 15301 of the CEQA Regulations, the repair, maintenance, or minor alteration of existing City streets is exempt, as long as there is no expansion (or only negligible expansion) of the use. Here, Staff is proposing to reconstruct the existing roadway slope on the west side of Grand Avenue, north of Baker Parkway and coldmill and overlay of existing AC pavement. The project does not result in an expansion of the use, as the streets are not being widened to allow for additional traffic. Based on the foregoing, Staff is recommending that the City Council adopt a Notice of Exemption for the project.

**Fiscal Impact:**

The fiscal impact is \$1,876,542.00. In the adopted Fiscal Year 2024-2025 Capital Improvement Project budget, \$2,000,000.00 is approved for this project (Account No. 120-702-5205, MP 20-01).

**Recommendation:**

1. Staff recommends that the City Council consider the results of the Grand Avenue Slope Reconstruction and Pavement Rehabilitation from Baker Parkway to Ferrero Parkway, bid and award the bid to Sol Construction, Inc.. and
2. Authorize the City Manager to approve change orders up to ten percent of the contract

amount; and

3. Staff recommends that the City Council adopt the Notice to Exemption for this project.

**Exhibits:**

1. Bid Results
2. Bid Schedule Packet (Page A-12 and Pages C-4R through C-13)
3. Contractor's State of California and Department of Industrial relations License Detail
4. Notice of Exemption

City of Industry  
 Bid Results for Project GRAND AVENUE SLOPE RECONSTRUCTION AND PAVEMENT  
 REHABILITATION FROM BAKER PARKWAY TO FERRERO PARKWAY (CITY-1531)  
 Issued on 01/15/2025  
 Bid Due on March 20, 2025 10:00 AM (PDT)  
 Line Totals (Unit Price \* Quantity)

Item No	Description	Unit of Measure	Quantity	JT Construction Group	
				Inc - Unit Price	Group Inc - Line Total
1	MOBILIZATION	LS	1	\$130,000.00	\$130,000.00
2	PREPARATION AND IMPLEMENTATION OF EROSION CONTROL PLANS	LS	1	\$35,000.00	\$35,000.00
3	TRAFFIC CONTROL	LS	1	\$60,000.00	\$60,000.00
4	CLEARING AND GRUBBING	LS	1	\$180,000.00	\$180,000.00
5	COLDMILL AND REMOVE EXISTING AC PAVEMENT. DEPTH 2"	SY	6811	\$15.00	\$102,165.00
6	SAWCUT AND REMOVE EXISTING AC PAVEMENT AND BASE MATERIAL,	SF	3205	\$17.00	\$54,485.00
7	SAWCUT AND REMOVE EXISTING PCC PAVEMENT AND BASE MATERIAL,	SY	569	\$20.00	\$11,380.00
8	SAWCUT AND REMOVE EXISTING PCC CURB AND GUTTER INCLUDING BASE.	LF	720	\$10.00	\$7,200.00
9	SAWCUT AND REMOVE EXISTING PCC SIDEWALK INCLUDING BASE.	SF	5325	\$10.00	\$53,250.00
10	SAWCUT AND REMOVE EXISTING CURB RAMP.	SF	315	\$15.00	\$4,725.00
11	SAWCUT AND REMOVE EXISTING CATCH BASIN, LOCAL DEPRESSION AND PORTION OF REINFORCED CONCRETE PIPE.	EA	1	\$5,000.00	\$5,000.00
12	SAWCUT AND REMOVE EXISTING PCC BRIDGE APPROACH SLAB, INCLUDING REINFORCEMENT.	EA	3	\$4,000.00	\$12,000.00
13	ADJUST PULLBOX OR UTILITY COVER AND FRAME TO FINISHED GRADE.	EA	3	\$1,500.00	\$4,500.00
14	ADJUST BLOWOFF AND COVER TO FINISHED GRADE.	EA	3	\$2,000.00	\$6,000.00
15	ADJUST FIRE HYDRANT TO FINISHED GRADE.	EA	1	\$2,000.00	\$2,000.00
16	CONSTRUCT 2-INCH THICK (C2 PG 64-10-R0) AC OVERLAY.	TN	782	\$200.00	\$156,400.00
17	CONSTRUCT STREET PAVEOUT AC PER CITY OF INDUSTRY STD. PLAN NO. 111.	TN	8	\$180.00	\$1,440.00
18	CONSTRUCT STREET PAVEOUT COMPACTED AGGREGATE BASE PER CITY OF INDUSTRY STD. PLAN NO. 111.	CY	8	\$50.00	\$400.00
19	CONSTRUCT 4.5" HIGH STABILITY AC (TYPE C2 PG 70-10-R0)	TN	91	\$180.00	\$16,380.00
20	CONSTRUCT 22" AC (TYPE B PG 64-10-R0) BASE COURSE	TN	445	\$160.00	\$71,200.00
21	CONSTRUCT 9" PCC PAVEMENT.	CY	134	\$30.00	\$4,020.00
22	CONSTRUCT 3" OF ASPHALT TREATED PERMEABLE BASE.	TN	45	\$150.00	\$6,750.00
23	CONSTRUCT 10" OF CRUSHED AGGREGATE BASE.	CY	149	\$200.00	\$29,800.00

Item No	Description	Unit of Measure	Quantity	JT Construction Group	
				Inc - Unit Price	Group Inc - Line Total
24	CONSTRUCT PCC CURB AND GUTTER TYPE A2 PER CITY OF INDUSTRY STD. PLAN 112 INCLUDING BASE MATERIAL.	LF	720	\$45.00	\$32,400.00
25	CONSTRUCT PCC SIDEWALK PER CITY OF INDUSTRY STD. PLAN 115 INCLUDING BASE MATERIAL.	SF	5325	\$10.00	\$53,250.00
26	CONSTRUCT CURB RAMP PER CALTRANS STD. PLAN A88A, CASE PER PLAN.	SF	420	\$12.00	\$5,040.00
27	CONSTRUCT LOCAL DEPRESSION PER SPPWC STD. PLAN 313-4, CASE E	EA	1	\$15,000.00	\$15,000.00
28	CONSTRUCT PCC STRUCTURE APPROACH TYPE R (10) PER CALTRANS STD. PLAN B9-2.	EA	3	\$55.00	\$165.00
29	CONSTRUCT CURB OPENING CATCH BASIN, W=10' AND H=2", PER SPPWC STD PLAN NO. 300-3.	EA	1	\$15,000.00	\$15,000.00
30	CONSTRUCT 18" RCP WITH SAND TRENCH BACKFILL.	LF	13	\$100.00	\$1,300.00
31	CONSTRUCT CONCRETE COLLAR PER SPPWC STD. PLAN 380-4	EA	2	\$5,000.00	\$10,000.00
32	CONSTRUCT MODIFIED MONOLITHIC CATCH BASIN CONNECTION PER SPPWC STD. PLAN 380-2	EA	1	\$6,000.00	\$6,000.00
33	CONSTRUCT 4" PERFORATED PVC SUBDRAIN WITH TRENCH.	LF	320	\$30.00	\$9,600.00
34	CONSTRUCT 6" PVC SUBDRAIN.	LF	465	\$35.00	\$16,275.00
35	CONSTRUCT PCC MOISTURE CUT-OFF BARRIER.	LF	80	\$55.00	\$4,400.00
36	CONSTRUCT 6" PVC SUBDRAIN CLEANOUT.	EA	1	\$2,500.00	\$2,500.00
37	UNCLASSIFIED EXCAVATION	CY	770	\$50.00	\$38,500.00
38	2' OVEREXCAVATION	CY	834	\$50.00	\$41,700.00
39	REGRADE SLOPE PER GEOTECHNICAL REPORT. UNCLASSIFIED FILL (IMPORT)	CY	1770	\$23.00	\$40,710.00
40	INSTALL LANDSCAPE PER LANDSCAPE PLANS.	LS	1	\$90,000.00	\$90,000.00
41	INSTALL IRRIGATION PER IRRIGATION PLANS.	LS	1	\$37,000.00	\$37,000.00
42	EXISTING LANDSCAPE AND IRRIGATION TO BE MODIFIED AS REQUIRED TO ACCOMMODATE IMPROVEMENTS.	LS	1	\$15,500.00	\$15,500.00
43	REMOVE AND SALVAGE EXISTING DECORATIVE ROCK AND REINSTALL IN GROUT TO MATCH ADJACENT GRADES.	LS	1	\$65,000.00	\$65,000.00
44	SIGNING AND STRIPING IMPROVEMENTS	LS	1	\$80,000.00	\$80,000.00
				<b>Subtotal</b>	<b>\$1,533,435.00</b>
45	REMOVE AND RELOCATE STREETLIGHT POLE AND REPLACE EXISTING 6' MASTARM WITH 8'.	EA	4	\$9,500.00	\$38,000.00
46	REPLACE EXISTING STREETLIGHT 6' MASTARM WITH 8'.	EA	1	\$950.00	\$950.00
47	FURNISH AND INSTALL NO.5 PULL BOX JENSEN CAT NO. CYN 20 OR APPROVED EQUAL FOR BOX AND JENSEN CAT NO. CYN16-61J OR APPROVED EQUAL FOR COVER WITH "COI ST LIGHT" MARKED ON THE COVER PER CALTRANS STD PLAN NO. RSP ES-8A.	EA	7	\$1,200.00	\$8,400.00

Item No	Description	Unit of Measure	Quantity	JT Construction Group	
				Inc - Unit Price	Group Inc - Line Total
48	FURNISH AND INSTALL NO.6 PULL BOX JENSEN CAT NO. HT1730-B FOR BOX JENSEN CAT NO. HT1730-L11-01 FOR COVER OR APPROVED EQUAL PER CALTRANS STD PLAN NO. RSP ES-8A.	EA	2	\$1,700.00	\$3,400.00
49	FURNISH AND INSTALL 160 W LUMINAIRES COOPER LIGHTING MODEL: ARCH-L-PA3-160-740-U-T3-AP-10MSP-10X OR APPROVED EQUAL.	EA	4	\$750.00	\$3,000.00
50	REPLACE EXISTING PULLBOX COVER WITH MARKING "COI ST LIGHT".	EA	1	\$450.00	\$450.00
51	FURNISH AND INSTALL 3" PVC SCHEDULE 40 CONDUIT MIN.30" DEEP BETWEEN PULLBOXES.	LF	1200	\$52.00	\$62,400.00
52	FURNISH AND INSTALL 1" PVC SCHEDULE 40 CONDUIT MIN.30" DEEP BETWEEN PULLBOX AND STREET LIGHT FOUNDATION.	LF	50	\$25.00	\$1,250.00
53	FURNISH AND INSTALL 1/0 STRANDED ALUMINUM XHHW WIRE WITHIN 3" PVC CONDUIT PULLBOXES.	LF	3000	\$4.00	\$12,000.00
54	FURNISH AND INSTALL #2 STRANDED ALUMINUM XHHW WIRE WITHIN 3" PVC CONDUIT.	LF	1500	\$1.75	\$2,625.00
55	FURNISH AND INSTALL #6 STRANDED ALUMINUM XHHW WIRES WITHIN 1"PVC CONDUIT TO HANDHOLE ON THE STREETLIGHT POLE.	LF	1500	\$1.25	\$1,875.00
56	FURNISH AND INSTALL FUSES COOPER BUSSMANN KTK-10 WITH FUSE HOLDER OR APPROVED EQUAL AT POLE'S HANDHOLE.	EA	13	\$50.00	\$650.00
57	FURNISH AND INSTALL 4-WAY SECONDARY BARS (3 CONNECTORS PER PB) UTILCO PED4-350SSP WITHIN PULL BOX.	EA	30	\$345.00	\$10,350.00
58	COMPRESSION CONNECTOR CAT NO: ES4W4W ON NEUTRAL WIRE FOR EACH STREETLIGHT POLE.	EA	13	\$15.00	\$195.00
59	INSTALL UBICQUIA WIRELESS STREETLIGHT CONTROLLER(NODE) CAT NO. UBC-30-0-01-NA-01-1-GY ON EACH LUMINAIRE (INCLUDE BUNDLE OF 5 YEAR CONNECTIVITY + 5 YEAR UBIVU SERVICES ) AND WORK WITH UBICQUIA TO MAKE REMOTE MONITORING SYSTEM FUNCTIONAL.	EA	4	\$850.00	\$3,400.00
60	FURNISH AND INSTALL (2) 40A, 1P,120/240 VOLT CIRCUIT BREAKER ON LOAD SIDE OF EXISTING METERING PEDESTAL.	EA	2	\$30.00	\$60.00
61	FURNISH AND INSTALL STREETLIGHT POLE FOUNDATION 2'X2'X4'-6".	EA	4	\$2,000.00	\$8,000.00
				Subtotal	\$157,005.00
				<b>Total</b>	<b>\$1,690,440.00</b>

City of Industry

Bid Results for Project GRAND AVENUE SLOPE RECONSTRUCTION AND PAVEMENT  
REHABILITATION FROM BAKER PARKWAY TO FERRERO PARKWAY (CITY-1531)

Issued on 01/15/2025

Bid Due on March 20, 2025 10:00 AM (PDT)

Line Totals (Unit Price \* Quantity)

Item No	Description	Unit of Measure	Quantity	Sol Construction, Inc - Sol Construction, Inc - CONTRACTING		SULLY-MILLER CONTRACTING	
				Unit Price	Line Total	COMPANY - Unit Price	COMPANY - Line Total
1	MOBILIZATION	LS	1	\$185,000.00	\$185,000.00	\$193,000.00	\$193,000.00
2	PREPARATION AND IMPLEMENTATION OF EROSION CONTROL PLANS	LS	1	\$18,075.00	\$18,075.00	\$40,000.00	\$40,000.00
3	TRAFFIC CONTROL	LS	1	\$66,275.00	\$66,275.00	\$190,000.00	\$190,000.00
4	CLEARING AND GRUBBING	LS	1	\$68,600.00	\$68,600.00	\$46,000.00	\$46,000.00
5	COLDMILL AND REMOVE EXISTING AC PAVEMENT. DEPTH 2"	SY	6811	\$8.00	\$54,488.00	\$5.50	\$37,460.50
6	SAWCUT AND REMOVE EXISTING AC PAVEMENT AND BASE MATERIAL,	SF	3205	\$11.00	\$35,255.00	\$6.50	\$20,832.50
7	SAWCUT AND REMOVE EXISTING PCC PAVEMENT AND BASE MATERIAL,	SY	569	\$96.00	\$54,624.00	\$85.00	\$48,365.00
8	SAWCUT AND REMOVE EXISTING PCC CURB AND GUTTER INCLUDING BASE.	LF	720	\$18.00	\$12,960.00	\$40.00	\$28,800.00
9	SAWCUT AND REMOVE EXISTING PCC SIDEWALK INCLUDING BASE.	SF	5325	\$5.00	\$26,625.00	\$6.00	\$31,950.00
10	SAWCUT AND REMOVE EXISTING CURB RAMP.	SF	315	\$43.00	\$13,545.00	\$15.00	\$4,725.00
11	SAWCUT AND REMOVE EXISTING CATCH BASIN, LOCAL DEPRESSION AND PORTION OF REINFORCED CONCRETE PIPE.	EA	1	\$30,000.00	\$30,000.00	\$7,000.00	\$7,000.00
12	SAWCUT AND REMOVE EXISTING PCC BRIDGE APPROACH SLAB, INCLUDING REINFORCEMENT.	EA	3	\$10,000.00	\$30,000.00	\$5,000.00	\$15,000.00
13	ADJUST PULLBOX OR UTILITY COVER AND FRAME TO FINISHED GRADE.	EA	3	\$600.00	\$1,800.00	\$2,000.00	\$6,000.00
14	ADJUST BLOWOFF AND COVER TO FINISHED GRADE.	EA	3	\$600.00	\$1,800.00	\$2,500.00	\$7,500.00
15	ADJUST FIRE HYDRANT TO FINISHED GRADE.	EA	1	\$8,160.00	\$8,160.00	\$4,800.00	\$4,800.00
16	CONSTRUCT 2-INCH THICK (C2 PG 64-10-R0) AC OVERLAY.	TN	782	\$199.00	\$155,618.00	\$165.00	\$129,030.00
17	CONSTRUCT STREET PAVEOUT AC PER CITY OF INDUSTRY STD. PLAN NO. 111.	TN	8	\$669.00	\$5,352.00	\$100.00	\$800.00
18	CONSTRUCT STREET PAVEOUT COMPACTED AGGREGATE BASE PER CITY OF INDUSTRY STD. PLAN NO. 111.	CY	8	\$538.00	\$4,304.00	\$50.00	\$400.00
19	CONSTRUCT 4.5" HIGH STABILITY AC (TYPE C2 PG 70-10-R0)	TN	91	\$257.00	\$23,387.00	\$430.00	\$39,130.00
20	CONSTRUCT 22" AC (TYPE B PG 64-10-R0) BASE COURSE	TN	445	\$241.00	\$107,245.00	\$180.00	\$80,100.00
21	CONSTRUCT 9" PCC PAVEMENT.	CY	134	\$488.00	\$65,392.00	\$430.00	\$57,620.00
22	CONSTRUCT 3" OF ASPHALT TREATED PERMEABLE BASE.	TN	45	\$393.00	\$17,685.00	\$250.00	\$11,250.00
23	CONSTRUCT 10" OF CRUSHED AGGREGATE BASE.	CY	149	\$160.00	\$23,840.00	\$120.00	\$17,880.00

Item No	Description	Unit of Measure	Quantity	Sol Construction, Inc - Unit Price	Sol Construction, Inc - Line Total	SULLY-MILLER	SULLY-MILLER
						CONTRACTING COMPANY - Unit Price	CONTRACTING COMPANY - Line Total
24	CONSTRUCT PCC CURB AND GUTTER TYPE A2 PER CITY OF INDUSTRY STD. PLAN 112 INCLUDING BASE MATERIAL.	LF	720	\$64.00	\$46,080.00	\$45.00	\$32,400.00
25	CONSTRUCT PCC SIDEWALK PER CITY OF INDUSTRY STD. PLAN 115 INCLUDING BASE MATERIAL.	SF	5325	\$11.00	\$58,575.00	\$11.00	\$58,575.00
26	CONSTRUCT CURB RAMP PER CALTRANS STD. PLAN A88A, CASE PER PLAN.	SF	420	\$30.00	\$12,600.00	\$20.00	\$8,400.00
27	CONSTRUCT LOCAL DEPRESSION PER SPPWC STD. PLAN 313-4, CASE E	EA	1	\$3,082.00	\$3,082.00	\$2,750.00	\$2,750.00
28	CONSTRUCT PCC STRUCTURE APPROACH TYPE R (10) PER CALTRANS STD. PLAN B9-2.	EA	3	\$12,864.00	\$38,592.00	\$14,500.00	\$43,500.00
29	CONSTRUCT CURB OPENING CATCH BASIN, W=10' AND H=2", PER SPPWC STD PLAN NO. 300-3.	EA	1	\$14,429.00	\$14,429.00	\$20,000.00	\$20,000.00
30	CONSTRUCT 18" RCP WITH SAND TRENCH BACKFILL.	LF	13	\$420.00	\$5,460.00	\$700.00	\$9,100.00
31	CONSTRUCT CONCRETE COLLAR PER SPPWC STD. PLAN 380-4	EA	2	\$1,442.00	\$2,884.00	\$2,000.00	\$4,000.00
32	CONSTRUCT MODIFIED MONOLITHIC CATCH BASIN CONNECTION PER SPPWC STD. PLAN 380-2	EA	1	\$3,360.00	\$3,360.00	\$2,000.00	\$2,000.00
33	CONSTRUCT 4" PERFORATED PVC SUBDRAIN WITH TRENCH.	LF	320	\$107.00	\$34,240.00	\$75.00	\$24,000.00
34	CONSTRUCT 6" PVC SUBDRAIN.	LF	465	\$91.00	\$42,315.00	\$40.00	\$18,600.00
35	CONSTRUCT PCC MOISTURE CUT-OFF BARRIER.	LF	80	\$165.00	\$13,200.00	\$85.00	\$6,800.00
36	CONSTRUCT 6" PVC SUBDRAIN CLEANOUT.	EA	1	\$600.00	\$600.00	\$2,400.00	\$2,400.00
37	UNCLASSIFIED EXCAVATION	CY	770	\$43.00	\$33,110.00	\$120.00	\$92,400.00
38	2' OVEREXCAVATION	CY	834	\$53.00	\$44,202.00	\$50.00	\$41,700.00
39	REGRADE SLOPE PER GEOTECHNICAL REPORT. UNCLASSIFIED FILL (IMPORT)	CY	1770	\$97.00	\$171,690.00	\$135.00	\$238,950.00
40	INSTALL LANDSCAPE PER LANDSCAPE PLANS.	LS	1	\$94,500.00	\$94,500.00	\$128,000.00	\$128,000.00
41	INSTALL IRRIGATION PER IRRIGATION PLANS.	LS	1	\$38,850.00	\$38,850.00	\$39,000.00	\$39,000.00
42	EXISTING LANDSCAPE AND IRRIGATION TO BE MODIFIED AS REQUIRED TO ACCOMMODATE IMPROVEMENTS.	LS	1	\$16,275.00	\$16,275.00	\$7,000.00	\$7,000.00
43	REMOVE AND SALVAGE EXISTING DECORATIVE ROCK AND REINSTALL IN GROUT TO MATCH ADJACENT GRADES.	LS	1	\$5,500.00	\$5,500.00	\$12,000.00	\$12,000.00
44	SIGNING AND STRIPING IMPROVEMENTS	LS	1	\$36,540.00	\$36,540.00	\$35,000.00	\$35,000.00
					\$1,726,114.00		\$1,844,218.00
45	REMOVE AND RELOCATE STREETLIGHT POLE AND REPLACE EXISTING 6' MASTARM WITH 8'.	EA	4	\$9,450.00	\$37,800.00	\$9,500.00	\$38,000.00
46	REPLACE EXISTING STREETLIGHT 6' MASTARM WITH 8'.	EA	1	\$945.00	\$945.00	\$920.00	\$920.00
47	FURNISH AND INSTALL NO.5 PULL BOX JENSEN CAT NO. CYN 20 OR APPROVED EQUAL FOR BOX AND JENSEN CAT NO. CYN16-61J OR APPROVED EQUAL FOR COVER WITH "COI ST LIGHT" MARKED ON THE COVER PER CALTRANS STD PLAN NO. RSP ES-8A.	EA	7	\$1,155.00	\$8,085.00	\$1,200.00	\$8,400.00

Item No	Description	Unit of Measure	Quantity	Sol Construction, Inc - Unit Price	Sol Construction, Inc - Line Total	SULLY-MILLER	SULLY-MILLER
						CONTRACTING COMPANY - Unit Price	CONTRACTING COMPANY - Line Total
48	FURNISH AND INSTALL NO.6 PULL BOX JENSEN CAT NO. HT1730-B FOR BOX JENSEN CAT NO. HT1730-L11-01 FOR COVER OR APPROVED EQUAL PER CALTRANS STD PLAN NO. RSP ES-8A.	EA	2	\$1,680.00	\$3,360.00	\$1,700.00	\$3,400.00
49	FURNISH AND INSTALL 160 W LUMINAIRES COOPER LIGHTING MODEL: ARCH-L-PA3-160-740-U-T3-AP-10MSP-10X OR APPROVED EQUAL.	EA	4	\$788.00	\$3,152.00	\$780.00	\$3,120.00
50	REPLACE EXISTING PULLBOX COVER WITH MARKING "COI ST LIGHT".	EA	1	\$473.00	\$473.00	\$460.00	\$460.00
51	FURNISH AND INSTALL 3" PVC SCHEDULE 40 CONDUIT MIN.30" DEEP BETWEEN PULLBOXES.	LF	1200	\$47.00	\$56,400.00	\$50.00	\$60,000.00
52	FURNISH AND INSTALL 1" PVC SCHEDULE 40 CONDUIT MIN.30" DEEP BETWEEN PULLBOX AND STREET LIGHT FOUNDATION.	LF	50	\$26.00	\$1,300.00	\$30.00	\$1,500.00
53	FURNISH AND INSTALL 1/0 STRANDED ALUMINUM XHHW WIRE WITHIN 3" PVC CONDUIT PULLBOXES.	LF	3000	\$2.10	\$6,300.00	\$2.00	\$6,000.00
54	FURNISH AND INSTALL #2 STRANDED ALUMINUM XHHW WIRE WITHIN 3" PVC CONDUIT.	LF	1500	\$2.00	\$3,000.00	\$2.00	\$3,000.00
55	FURNISH AND INSTALL #6 STRANDED ALUMINUM XHHW WIRES WITHIN 1"PVC CONDUIT TO HANDHOLE ON THE STREETLIGHT POLE.	LF	1500	\$1.50	\$2,250.00	\$1.28	\$1,920.00
56	FURNISH AND INSTALL FUSES COOPER BUSSMANN KTK-10 WITH FUSE HOLDER OR APPROVED EQUAL AT POLE'S HANDHOLE.	EA	13	\$53.00	\$689.00	\$55.00	\$715.00
57	FURNISH AND INSTALL 4-WAY SECONDARY BARS (3 CONNECTORS PER PB) UTILCO PED4-350SSP WITHIN PULL BOX.	EA	30	\$341.00	\$10,230.00	\$350.00	\$10,500.00
58	COMPRESSION CONNECTOR CAT NO: ES4W4W ON NEUTRAL WIRE FOR EACH STREETLIGHT POLE.	EA	13	\$16.00	\$208.00	\$20.00	\$260.00
59	INSTALL UBICQUIA WIRELESS STREETLIGHT CONTROLLER(NODE) CAT NO. UBC-30-0-01-NA-01-1-GY ON EACH LUMINAIRE (INCLUDE BUNDLE OF 5 YEAR CONNECTIVITY + 5 YEAR UBIVU SERVICES ) AND WORK WITH UBICQUIA TO MAKE REMOTE MONITORING SYSTEM FUNCTIONAL.	EA	4	\$893.00	\$3,572.00	\$900.00	\$3,600.00
60	FURNISH AND INSTALL (2) 40A, 1P,120/240 VOLT CIRCUIT BREAKER ON LOAD SIDE OF EXISTING METERING PEDESTAL.	EA	2	\$32.00	\$64.00	\$35.00	\$70.00
61	FURNISH AND INSTALL STREETLIGHT POLE FOUNDATION 2'X2'X4'-6".	EA	4	\$3,150.00	\$12,600.00	\$3,100.00	\$12,400.00
					\$150,428.00		\$154,265.00
					<b>\$1,876,542.00</b>		<b>\$1,998,483.00</b>

City of Industry

Bid Results for Project GRAND AVENUE SLOPE RECONSTRUCTION AND PAVEMENT  
REHABILITATION FROM BAKER PARKWAY TO FERRERO PARKWAY (CITY-1531)

Issued on 01/15/2025

Bid Due on March 20, 2025 10:00 AM (PDT)

Line Totals (Unit Price \* Quantity)

Item No	Description	Unit of Measure	Quantity	Gentry Brothers, Inc. -		Sequel Contractors, Inc. -	
				Unit Price	- Line Total	Inc. - Unit Price	Inc. - Line Total
1	MOBILIZATION	LS	1	\$100,000.00	\$100,000.00	\$200,000.00	\$200,000.00
2	PREPARATION AND IMPLEMENTATION OF EROSION CONTROL PLANS	LS	1	\$20,000.00	\$20,000.00	\$50,000.00	\$50,000.00
3	TRAFFIC CONTROL	LS	1	\$105,000.00	\$105,000.00	\$239,999.00	\$239,999.00
4	CLEARING AND GRUBBING	LS	1	\$321,000.00	\$321,000.00	\$250,000.00	\$250,000.00
5	COLDMILL AND REMOVE EXISTING AC PAVEMENT. DEPTH 2"	SY	6811	\$5.00	\$34,055.00	\$3.50	\$23,838.50
6	SAWCUT AND REMOVE EXISTING AC PAVEMENT AND BASE MATERIAL,	SF	3205	\$5.00	\$16,025.00	\$4.25	\$13,621.25
7	SAWCUT AND REMOVE EXISTING PCC PAVEMENT AND BASE MATERIAL,	SY	569	\$32.00	\$18,208.00	\$70.00	\$39,830.00
8	SAWCUT AND REMOVE EXISTING PCC CURB AND GUTTER INCLUDING BASE.	LF	720	\$30.00	\$21,600.00	\$23.00	\$16,560.00
9	SAWCUT AND REMOVE EXISTING PCC SIDEWALK INCLUDING BASE.	SF	5325	\$4.00	\$21,300.00	\$2.75	\$14,643.75
10	SAWCUT AND REMOVE EXISTING CURB RAMP.	SF	315	\$14.00	\$4,410.00	\$10.00	\$3,150.00
11	SAWCUT AND REMOVE EXISTING CATCH BASIN, LOCAL DEPRESSION AND PORTION OF REINFORCED CONCRETE PIPE.	EA	1	\$5,000.00	\$5,000.00	\$2,000.00	\$2,000.00
12	SAWCUT AND REMOVE EXISTING PCC BRIDGE APPROACH SLAB, INCLUDING REINFORCEMENT.	EA	3	\$1,500.00	\$4,500.00	\$5,000.00	\$15,000.00
13	ADJUST PULLBOX OR UTILITY COVER AND FRAME TO FINISHED GRADE.	EA	3	\$300.00	\$900.00	\$500.00	\$1,500.00
14	ADJUST BLOWOFF AND COVER TO FINISHED GRADE.	EA	3	\$1,250.00	\$3,750.00	\$7,000.00	\$21,000.00
15	ADJUST FIRE HYDRANT TO FINISHED GRADE.	EA	1	\$5,000.00	\$5,000.00	\$8,000.00	\$8,000.00
16	CONSTRUCT 2-INCH THICK (C2 PG 64-10-R0) AC OVERLAY.	TN	782	\$97.00	\$75,854.00	\$120.00	\$93,840.00
17	CONSTRUCT STREET PAVEOUT AC PER CITY OF INDUSTRY STD. PLAN NO. 111.	TN	8	\$100.00	\$800.00	\$500.00	\$4,000.00
18	CONSTRUCT STREET PAVEOUT COMPACTED AGGREGATE BASE PER CITY OF INDUSTRY STD. PLAN NO. 111.	CY	8	\$75.00	\$600.00	\$150.00	\$1,200.00
19	CONSTRUCT 4.5" HIGH STABILITY AC (TYPE C2 PG 70-10-R0)	TN	91	\$135.00	\$12,285.00	\$145.00	\$13,195.00
20	CONSTRUCT 22" AC (TYPE B PG 64-10-R0) BASE COURSE	TN	445	\$135.00	\$60,075.00	\$125.00	\$55,625.00
21	CONSTRUCT 9" PCC PAVEMENT.	CY	134	\$220.00	\$29,480.00	\$600.00	\$80,400.00
22	CONSTRUCT 3" OF ASPHALT TREATED PERMEABLE BASE.	TN	45	\$120.00	\$5,400.00	\$850.00	\$38,250.00
23	CONSTRUCT 10" OF CRUSHED AGGREGATE BASE.	CY	149	\$70.00	\$10,430.00	\$175.00	\$26,075.00

Item No	Description	Unit of Measure	Quantity	Gentry Brothers, Inc. -		Sequel Contractors,	
				Unit Price	- Line Total	Inc. - Unit Price	Inc. - Line Total
24	CONSTRUCT PCC CURB AND GUTTER TYPE A2 PER CITY OF INDUSTRY STD. PLAN 112 INCLUDING BASE MATERIAL.	LF	720	\$65.00	\$46,800.00	\$40.00	\$28,800.00
25	CONSTRUCT PCC SIDEWALK PER CITY OF INDUSTRY STD. PLAN 115 INCLUDING BASE MATERIAL.	SF	5325	\$8.00	\$42,600.00	\$10.00	\$53,250.00
26	CONSTRUCT CURB RAMP PER CALTRANS STD. PLAN A88A, CASE PER PLAN.	SF	420	\$40.00	\$16,800.00	\$30.00	\$12,600.00
27	CONSTRUCT LOCAL DEPRESSION PER SPPWC STD. PLAN 313-4, CASE E	EA	1	\$2,500.00	\$2,500.00	\$2,500.00	\$2,500.00
28	CONSTRUCT PCC STRUCTURE APPROACH TYPE R (10) PER CALTRANS STD. PLAN B9-2.	EA	3	\$1,500.00	\$4,500.00	\$25,000.00	\$75,000.00
29	CONSTRUCT CURB OPENING CATCH BASIN, W=10' AND H=2", PER SPPWC STD PLAN NO. 300-3.	EA	1	\$15,000.00	\$15,000.00	\$20,000.00	\$20,000.00
30	CONSTRUCT 18" RCP WITH SAND TRENCH BACKFILL.	LF	13	\$200.00	\$2,600.00	\$1,200.00	\$15,600.00
31	CONSTRUCT CONCRETE COLLAR PER SPPWC STD. PLAN 380-4	EA	2	\$3,000.00	\$6,000.00	\$2,000.00	\$4,000.00
32	CONSTRUCT MODIFIED MONOLITHIC CATCH BASIN CONNECTION PER SPPWC STD. PLAN 380-2	EA	1	\$7,500.00	\$7,500.00	\$2,500.00	\$2,500.00
33	CONSTRUCT 4" PERFORATED PVC SUBDRAIN WITH TRENCH.	LF	320	\$25.00	\$8,000.00	\$85.00	\$27,200.00
34	CONSTRUCT 6" PVC SUBDRAIN.	LF	465	\$35.00	\$16,275.00	\$60.00	\$27,900.00
35	CONSTRUCT PCC MOISTURE CUT-OFF BARRIER.	LF	80	\$30.00	\$2,400.00	\$200.00	\$16,000.00
36	CONSTRUCT 6" PVC SUBDRAIN CLEANOUT.	EA	1	\$2,500.00	\$2,500.00	\$1,000.00	\$1,000.00
37	UNCLASSIFIED EXCAVATION	CY	770	\$200.00	\$154,000.00	\$100.00	\$77,000.00
38	2' OVEREXCAVATION	CY	834	\$200.00	\$166,800.00	\$200.00	\$166,800.00
39	REGRADE SLOPE PER GEOTECHNICAL REPORT. UNCLASSIFIED FILL (IMPORT)	CY	1770	\$200.00	\$354,000.00	\$100.00	\$177,000.00
40	INSTALL LANDSCAPE PER LANDSCAPE PLANS.	LS	1	\$110,000.00	\$110,000.00	\$75,000.00	\$75,000.00
41	INSTALL IRRIGATION PER IRRIGATION PLANS.	LS	1	\$44,000.00	\$44,000.00	\$35,000.00	\$35,000.00
42	EXISTING LANDSCAPE AND IRRIGATION TO BE MODIFIED AS REQUIRED TO ACCOMMODATE IMPROVEMENTS.	LS	1	\$20,000.00	\$20,000.00	\$15,000.00	\$15,000.00
43	REMOVE AND SALVAGE EXISTING DECORATIVE ROCK AND REINSTALL IN GROUT TO MATCH ADJACENT GRADES.	LS	1	\$5,000.00	\$5,000.00	\$2,500.00	\$2,500.00
44	SIGNING AND STRIPING IMPROVEMENTS	LS	1	\$40,000.00	\$40,000.00	\$30,000.00	\$30,000.00
					\$1,942,947.00		\$2,076,377.50
45	REMOVE AND RELOCATE STREETLIGHT POLE AND REPLACE EXISTING 6' MASTARM WITH 8'.	EA	4	\$10,800.00	\$43,200.00	\$4,000.00	\$16,000.00
46	REPLACE EXISTING STREETLIGHT 6' MASTARM WITH 8'.	EA	1	\$1,080.00	\$1,080.00	\$1,500.00	\$1,500.00
47	FURNISH AND INSTALL NO.5 PULL BOX JENSEN CAT NO. CYN 20 OR APPROVED EQUAL FOR BOX AND JENSEN CAT NO. CYN16-61J OR APPROVED EQUAL FOR COVER WITH "COI ST LIGHT" MARKED ON THE COVER PER CALTRANS STD PLAN NO. RSP ES-8A.	EA	7	\$1,320.00	\$9,240.00	\$2,400.00	\$16,800.00

Item No	Description	Unit of Measure	Quantity	Gentry Brothers, Inc. -		Sequel Contractors,	
				Unit Price	- Line Total	Inc. - Unit Price	Inc. - Line Total
48	FURNISH AND INSTALL NO.6 PULL BOX JENSEN CAT NO. HT1730-B FOR BOX JENSEN CAT NO. HT1730-L11-01 FOR COVER OR APPROVED EQUAL PER CALTRANS STD PLAN NO. RSP ES-8A.	EA	2	\$1,920.00	\$3,840.00	\$3,000.00	\$6,000.00
49	FURNISH AND INSTALL 160 W LUMINAIRES COOPER LIGHTING MODEL: ARCH-L-PA3-160-740-U-T3-AP-10MSP-10X OR APPROVED EQUAL.	EA	4	\$900.00	\$3,600.00	\$2,000.00	\$8,000.00
50	REPLACE EXISTING PULLBOX COVER WITH MARKING "COI ST LIGHT".	EA	1	\$540.00	\$540.00	\$500.00	\$500.00
51	FURNISH AND INSTALL 3" PVC SCHEDULE 40 CONDUIT MIN.30" DEEP BETWEEN PULLBOXES.	LF	1200	\$53.76	\$64,512.00	\$40.00	\$48,000.00
52	FURNISH AND INSTALL 1" PVC SCHEDULE 40 CONDUIT MIN.30" DEEP BETWEEN PULLBOX AND STREET LIGHT FOUNDATION.	LF	50	\$30.00	\$1,500.00	\$70.00	\$3,500.00
53	FURNISH AND INSTALL 1/0 STRANDED ALUMINUM XHHW WIRE WITHIN 3" PVC CONDUIT PULLBOXES.	LF	3000	\$2.40	\$7,200.00	\$3.00	\$9,000.00
54	FURNISH AND INSTALL #2 STRANDED ALUMINUM XHHW WIRE WITHIN 3" PVC CONDUIT.	LF	1500	\$2.10	\$3,150.00	\$2.00	\$3,000.00
55	FURNISH AND INSTALL #6 STRANDED ALUMINUM XHHW WIRES WITHIN 1"PVC CONDUIT TO HANDHOLE ON THE STREETLIGHT POLE.	LF	1500	\$1.50	\$2,250.00	\$1.80	\$2,700.00
56	FURNISH AND INSTALL FUSES COOPER BUSSMANN KTK-10 WITH FUSE HOLDER OR APPROVED EQUAL AT POLE'S HANDHOLE.	EA	13	\$60.00	\$780.00	\$300.00	\$3,900.00
57	FURNISH AND INSTALL 4-WAY SECONDARY BARS (3 CONNECTORS PER PB) UTILCO PED4-350SSP WITHIN PULL BOX.	EA	30	\$390.00	\$11,700.00	\$250.00	\$7,500.00
58	COMPRESSION CONNECTOR CAT NO: ES4W4W ON NEUTRAL WIRE FOR EACH STREETLIGHT POLE.	EA	13	\$18.00	\$234.00	\$250.00	\$3,250.00
59	INSTALL UBICQUIA WIRELESS STREETLIGHT CONTROLLER(NODE) CAT NO. UBC-30-0-01-NA-01-1-GY ON EACH LUMINAIRE (INCLUDE BUNDLE OF 5 YEAR CONNECTIVITY + 5 YEAR UBIVU SERVICES ) AND WORK WITH UBICQUIA TO MAKE REMOTE MONITORING SYSTEM FUNCTIONAL.	EA	4	\$1,020.00	\$4,080.00	\$400.00	\$1,600.00
60	FURNISH AND INSTALL (2) 40A, 1P,120/240 VOLT CIRCUIT BREAKER ON LOAD SIDE OF EXISTING METERING PEDESTAL.	EA	2	\$36.00	\$72.00	\$300.00	\$600.00
61	FURNISH AND INSTALL STREETLIGHT POLE FOUNDATION 2'X2'X4'-6".	EA	4	\$3,600.00	\$14,400.00	\$5,000.00	\$20,000.00
					\$171,378.00		\$151,850.00
					<b>\$2,114,325.00</b>		<b>\$2,228,227.50</b>

City of Industry

Bid Results for Project GRAND AVENUE SLOPE RECONSTRUCTION AND PAVEMENT  
REHABILITATION FROM BAKER PARKWAY TO FERRERO PARKWAY (CITY-1531)

Issued on 01/15/2025

Bid Due on March 20, 2025 10:00 AM (PDT)

Line Totals (Unit Price \* Quantity)

Item No	Description	Unit of Measure	Quantity	TTS Engineering Inc	TTS Engineering Inc -	ANEEN CONSTRUCTION,	ANEEN
				- Unit Price	Line Total	INC. - Unit Price	CONSTRUCTION, INC. - Line Total
1	MOBILIZATION	LS	1	\$73,000.00	\$73,000.00	\$125,000.00	\$125,000.00
2	PREPARATION AND IMPLEMENTATION OF EROSION CONTROL PLANS	LS	1	\$77,000.00	\$77,000.00	\$6,000.00	\$6,000.00
3	TRAFFIC CONTROL	LS	1	\$34,000.00	\$34,000.00	\$150,000.00	\$150,000.00
4	CLEARING AND GRUBBING	LS	1	\$98,000.00	\$98,000.00	\$40,000.00	\$40,000.00
5	COLDMILL AND REMOVE EXISTING AC PAVEMENT. DEPTH 2"	SY	6811	\$5.21	\$35,485.31	\$5.00	\$34,055.00
6	SAWCUT AND REMOVE EXISTING AC PAVEMENT AND BASE MATERIAL,	SF	3205	\$11.77	\$37,722.85	\$5.00	\$16,025.00
7	SAWCUT AND REMOVE EXISTING PCC PAVEMENT AND BASE MATERIAL,	SY	569	\$82.60	\$46,999.40	\$100.00	\$56,900.00
8	SAWCUT AND REMOVE EXISTING PCC CURB AND GUTTER INCLUDING BASE.	LF	720	\$22.87	\$16,466.40	\$25.00	\$18,000.00
9	SAWCUT AND REMOVE EXISTING PCC SIDEWALK INCLUDING BASE.	SF	5325	\$9.33	\$49,682.25	\$8.00	\$42,600.00
10	SAWCUT AND REMOVE EXISTING CURB RAMP.	SF	315	\$11.50	\$3,622.50	\$20.00	\$6,300.00
11	SAWCUT AND REMOVE EXISTING CATCH BASIN, LOCAL DEPRESSION AND PORTION OF REINFORCED CONCRETE PIPE.	EA	1	\$13,482.00	\$13,482.00	\$10,000.00	\$10,000.00
12	SAWCUT AND REMOVE EXISTING PCC BRIDGE APPROACH SLAB, INCLUDING REINFORCEMENT.	EA	3	\$7,532.00	\$22,596.00	\$20,000.00	\$60,000.00
13	ADJUST PULLBOX OR UTILITY COVER AND FRAME TO FINISHED GRADE.	EA	3	\$2,092.00	\$6,276.00	\$3,000.00	\$9,000.00
14	ADJUST BLOWOFF AND COVER TO FINISHED GRADE.	EA	3	\$2,194.00	\$6,582.00	\$5,000.00	\$15,000.00
15	ADJUST FIRE HYDRANT TO FINISHED GRADE.	EA	1	\$3,570.00	\$3,570.00	\$5,000.00	\$5,000.00
16	CONSTRUCT 2-INCH THICK (C2 PG 64-10-R0) AC OVERLAY.	TN	782	\$205.00	\$160,310.00	\$160.00	\$125,120.00
17	CONSTRUCT STREET PAVEOUT AC PER CITY OF INDUSTRY STD. PLAN NO. 111. CONSTRUCT STREET PAVEOUT COMPACTED AGGREGATE BASE PER CITY OF	TN	8	\$850.00	\$6,800.00	\$1,500.00	\$12,000.00
18	INDUSTRY STD. PLAN NO. 111.	CY	8	\$620.11	\$4,960.88	\$3,000.00	\$24,000.00
19	CONSTRUCT 4.5" HIGH STABILITY AC (TYPE C2 PG 70-10-R0)	TN	91	\$410.00	\$37,310.00	\$350.00	\$31,850.00
20	CONSTRUCT 22" AC (TYPE B PG 64-10-R0) BASE COURSE	TN	445	\$398.00	\$177,110.00	\$350.00	\$155,750.00
21	CONSTRUCT 9" PCC PAVEMENT.	CY	134	\$496.12	\$66,480.08	\$4,000.00	\$536,000.00
22	CONSTRUCT 3" OF ASPHALT TREATED PERMEABLE BASE.	TN	45	\$410.00	\$18,450.00	\$350.00	\$15,750.00
23	CONSTRUCT 10" OF CRUSHED AGGREGATE BASE.	CY	149	\$162.79	\$24,255.71	\$180.00	\$26,820.00

Item No	Description	Unit of Measure	Quantity	TTS Engineering Inc	TTS Engineering Inc -	ANEEN CONSTRUCTION,	ANEEN
				- Unit Price	Line Total	INC. - Unit Price	CONSTRUCTION, INC. - Line Total
24	CONSTRUCT PCC CURB AND GUTTER TYPE A2 PER CITY OF INDUSTRY STD. PLAN 112 INCLUDING BASE MATERIAL.	LF	720	\$98.38	\$70,833.60	\$60.00	\$43,200.00
25	CONSTRUCT PCC SIDEWALK PER CITY OF INDUSTRY STD. PLAN 115 INCLUDING BASE MATERIAL.	SF	5325	\$15.02	\$79,981.50	\$12.00	\$63,900.00
26	CONSTRUCT CURB RAMP PER CALTRANS STD. PLAN A88A, CASE PER PLAN.	SF	420	\$50.48	\$21,201.60	\$20.00	\$8,400.00
27	CONSTRUCT LOCAL DEPRESSION PER SPPWC STD. PLAN 313-4, CASE E	EA	1	\$8,849.00	\$8,849.00	\$2,500.00	\$2,500.00
28	CONSTRUCT PCC STRUCTURE APPROACH TYPE R (10) PER CALTRANS STD. PLAN B9-2.	EA	3	\$25,110.00	\$75,330.00	\$20,000.00	\$60,000.00
29	CONSTRUCT CURB OPENING CATCH BASIN, W=10' AND H=2", PER SPPWC STD PLAN NO. 300-3.	EA	1	\$16,362.00	\$16,362.00	\$25,000.00	\$25,000.00
30	CONSTRUCT 18" RCP WITH SAND TRENCH BACKFILL.	LF	13	\$1,616.41	\$21,013.33	\$900.00	\$11,700.00
31	CONSTRUCT CONCRETE COLLAR PER SPPWC STD. PLAN 380-4	EA	2	\$1,914.00	\$3,828.00	\$5,000.00	\$10,000.00
32	CONSTRUCT MODIFIED MONOLITHIC CATCH BASIN CONNECTION PER SPPWC STD. PLAN 380-2	EA	1	\$1,444.00	\$1,444.00	\$25,000.00	\$25,000.00
33	CONSTRUCT 4" PERFORATED PVC SUBDRAIN WITH TRENCH.	LF	320	\$61.18	\$19,577.60	\$120.00	\$38,400.00
34	CONSTRUCT 6" PVC SUBDRAIN.	LF	465	\$60.00	\$27,900.00	\$120.00	\$55,800.00
35	CONSTRUCT PCC MOISTURE CUT-OFF BARRIER.	LF	80	\$52.06	\$4,164.80	\$100.00	\$8,000.00
36	CONSTRUCT 6" PVC SUBDRAIN CLEANOUT.	EA	1	\$2,954.00	\$2,954.00	\$2,500.00	\$2,500.00
37	UNCLASSIFIED EXCAVATION	CY	770	\$113.00	\$87,010.00	\$120.00	\$92,400.00
38	2' OVEREXCAVATION	CY	834	\$100.00	\$83,400.00	\$120.00	\$100,080.00
39	REGRADE SLOPE PER GEOTECHNICAL REPORT. UNCLASSIFIED FILL (IMPORT)	CY	1770	\$246.00	\$435,420.00	\$110.00	\$194,700.00
40	INSTALL LANDSCAPE PER LANDSCAPE PLANS.	LS	1	\$122,500.00	\$122,500.00	\$99,000.00	\$99,000.00
41	INSTALL IRRIGATION PER IRRIGATION PLANS.	LS	1	\$56,790.00	\$56,790.00	\$42,000.00	\$42,000.00
42	EXISTING LANDSCAPE AND IRRIGATION TO BE MODIFIED AS REQUIRED TO ACCOMMODATE IMPROVEMENTS.	LS	1	\$44,872.00	\$44,872.00	\$17,000.00	\$17,000.00
43	REMOVE AND SALVAGE EXISTING DECORATIVE ROCK AND REINSTALL IN GROUT TO MATCH ADJACENT GRADES.	LS	1	\$53,000.00	\$53,000.00	\$10,000.00	\$10,000.00
44	SIGNING AND STRIPING IMPROVEMENTS	LS	1	\$50,000.00	\$50,000.00	\$54,000.00	\$54,000.00
					\$2,306,592.81		\$2,484,750.00
45	REMOVE AND RELOCATE STREETLIGHT POLE AND REPLACE EXISTING 6' MASTARM WITH 8'.	EA	4	\$15,000.00	\$60,000.00	\$10,500.00	\$42,000.00
46	REPLACE EXISTING STREETLIGHT 6' MASTARM WITH 8'.	EA	1	\$6,000.00	\$6,000.00	\$1,050.00	\$1,050.00
47	FURNISH AND INSTALL NO.5 PULL BOX JENSEN CAT NO. CYN 20 OR APPROVED EQUAL FOR BOX AND JENSEN CAT NO. CYN16-61J OR APPROVED EQUAL FOR COVER WITH "COI ST LIGHT" MARKED ON THE COVER PER CALTRANS STD PLAN NO. RSP ES-8A.	EA	7	\$690.00	\$4,830.00	\$1,500.00	\$10,500.00

Item No	Description	Unit of Measure	Quantity	TTS Engineering Inc	TTS Engineering Inc -	ANEEN CONSTRUCTION,	ANEEN
				- Unit Price	Line Total	INC. - Unit Price	CONSTRUCTION, INC. - Line Total
48	FURNISH AND INSTALL NO.6 PULL BOX JENSEN CAT NO. HT1730-B FOR BOX JENSEN CAT NO. HT1730-L11-01 FOR COVER OR APPROVED EQUAL PER CALTRANS STD PLAN NO. RSP ES-8A.	EA	2	\$3,900.00	\$7,800.00	\$1,900.00	\$3,800.00
49	FURNISH AND INSTALL 160 W LUMINAIRES COOPER LIGHTING MODEL: ARCH-L-PA3-160-740-U-T3-AP-10MSP-10X OR APPROVED EQUAL.	EA	4	\$1,500.00	\$6,000.00	\$900.00	\$3,600.00
50	REPLACE EXISTING PULLBOX COVER WITH MARKING "COI ST LIGHT".	EA	1	\$4,200.00	\$4,200.00	\$600.00	\$600.00
51	FURNISH AND INSTALL 3" PVC SCHEDULE 40 CONDUIT MIN.30" DEEP BETWEEN PULLBOXES.	LF	1200	\$46.80	\$56,160.00	\$58.00	\$69,600.00
52	FURNISH AND INSTALL 1" PVC SCHEDULE 40 CONDUIT MIN.30" DEEP BETWEEN PULLBOX AND STREET LIGHT FOUNDATION.	LF	50	\$102.00	\$5,100.00	\$30.00	\$1,500.00
53	FURNISH AND INSTALL 1/0 STRANDED ALUMINUM XHHW WIRE WITHIN 3" PVC CONDUIT PULLBOXES.	LF	3000	\$7.20	\$21,600.00	\$2.50	\$7,500.00
54	FURNISH AND INSTALL #2 STRANDED ALUMINUM XHHW WIRE WITHIN 3" PVC CONDUIT.	LF	1500	\$6.00	\$9,000.00	\$2.00	\$3,000.00
55	FURNISH AND INSTALL #6 STRANDED ALUMINUM XHHW WIRES WITHIN 1"PVC CONDUIT TO HANDHOLE ON THE STREETLIGHT POLE.	LF	1500	\$4.80	\$7,200.00	\$1.50	\$2,250.00
56	FURNISH AND INSTALL FUSES COOPER BUSSMANN KTK-10 WITH FUSE HOLDER OR APPROVED EQUAL AT POLE'S HANDHOLE.	EA	13	\$612.00	\$7,956.00	\$60.00	\$780.00
57	FURNISH AND INSTALL 4-WAY SECONDARY BARS (3 CONNECTORS PER PB) UTILCO PED4-350SSP WITHIN PULL BOX.	EA	30	\$672.00	\$20,160.00	\$400.00	\$12,000.00
58	COMPRESSION CONNECTOR CAT NO: ES4W4W ON NEUTRAL WIRE FOR EACH STREETLIGHT POLE.	EA	13	\$840.00	\$10,920.00	\$18.00	\$234.00
59	INSTALL UBICQUIA WIRELESS STREETLIGHT CONTROLLER(NODE) CAT NO. UBC-30-0-01-NA-01-1-GY ON EACH LUMINAIRE (INCLUDE BUNDLE OF 5 YEAR CONNECTIVITY + 5 YEAR UBIVU SERVICES ) AND WORK WITH UBICQUIA TO MAKE REMOTE MONITORING SYSTEM FUNCTIONAL.	EA	4	\$2,610.00	\$10,440.00	\$1,000.00	\$4,000.00
60	FURNISH AND INSTALL (2) 40A, 1P,120/240 VOLT CIRCUIT BREAKER ON LOAD SIDE OF EXISTING METERING PEDESTAL.	EA	2	\$942.00	\$1,884.00	\$40.00	\$80.00
61	FURNISH AND INSTALL STREETLIGHT POLE FOUNDATION 2'X2'X4'-6".	EA	4	\$468.00	\$1,872.00	\$2,500.00	\$10,000.00
					\$241,122.00		\$172,494.00
					<b>\$2,547,714.81</b>		<b>\$2,657,244.00</b>

City of Industry

Bid Results for Project GRAND AVENUE SLOPE RECONSTRUCTION AND PAVEMENT  
REHABILITATION FROM BAKER PARKWAY TO FERRERO PARKWAY (CITY-1531)

Issued on 01/15/2025

Bid Due on March 20, 2025 10:00 AM (PDT)

Line Totals (Unit Price \* Quantity)

Item No	Description	Unit of Measure	Quantity	Mike Bubalo Construction Co., Inc. - Unit Price	Mike Bubalo	Alfaro	Alfaro Communications
					Construction Co., Inc. - Line Total	Construction, Inc. - Unit Price	Construction, Inc. - Line Total
1	MOBILIZATION	LS	1	\$280,000.00	\$280,000.00	\$142,467.00	\$142,467.00
2	PREPARATION AND IMPLEMENTATION OF EROSION CONTROL PLANS	LS	1	\$35,000.00	\$35,000.00	\$13,195.00	\$13,195.00
3	TRAFFIC CONTROL	LS	1	\$45,000.00	\$45,000.00	\$48,750.00	\$48,750.00
4	CLEARING AND GRUBBING	LS	1	\$200,000.00	\$200,000.00	\$74,230.00	\$74,230.00
5	COLDMILL AND REMOVE EXISTING AC PAVEMENT. DEPTH 2"	SY	6811	\$15.00	\$102,165.00	\$6.85	\$46,655.35
6	SAWCUT AND REMOVE EXISTING AC PAVEMENT AND BASE MATERIAL,	SF	3205	\$20.00	\$64,100.00	\$8.09	\$25,928.45
7	SAWCUT AND REMOVE EXISTING PCC PAVEMENT AND BASE MATERIAL,	SY	569	\$120.00	\$68,280.00	\$318.66	\$181,317.54
8	SAWCUT AND REMOVE EXISTING PCC CURB AND GUTTER INCLUDING BASE.	LF	720	\$60.00	\$43,200.00	\$74.57	\$53,690.40
9	SAWCUT AND REMOVE EXISTING PCC SIDEWALK INCLUDING BASE.	SF	5325	\$15.00	\$79,875.00	\$8.80	\$46,860.00
10	SAWCUT AND REMOVE EXISTING CURB RAMP.	SF	315	\$50.00	\$15,750.00	\$21.17	\$6,668.55
11	SAWCUT AND REMOVE EXISTING CATCH BASIN, LOCAL DEPRESSION AND PORTION OF REINFORCED CONCRETE PIPE.	EA	1	\$25,000.00	\$25,000.00	\$18,630.00	\$18,630.00
12	SAWCUT AND REMOVE EXISTING PCC BRIDGE APPROACH SLAB, INCLUDING REINFORCEMENT.	EA	3	\$5,000.00	\$15,000.00	\$6,671.17	\$20,013.51
13	ADJUST PULLBOX OR UTILITY COVER AND FRAME TO FINISHED GRADE.	EA	3	\$2,000.00	\$6,000.00	\$962.00	\$2,886.00
14	ADJUST BLOWOFF AND COVER TO FINISHED GRADE.	EA	3	\$2,000.00	\$6,000.00	\$10,235.00	\$30,705.00
15	ADJUST FIRE HYDRANT TO FINISHED GRADE.	EA	1	\$5,000.00	\$5,000.00	\$11,270.00	\$11,270.00
16	CONSTRUCT 2-INCH THICK (C2 PG 64-10-R0) AC OVERLAY.	TN	782	\$150.00	\$117,300.00	\$305.89	\$239,205.98
17	CONSTRUCT STREET PAVEOUT AC PER CITY OF INDUSTRY STD. PLAN NO. 111.	TN	8	\$1,500.00	\$12,000.00	\$1,657.50	\$13,260.00
18	CONSTRUCT STREET PAVEOUT COMPACTED AGGREGATE BASE PER CITY OF INDUSTRY STD. PLAN NO. 111.	CY	8	\$1,500.00	\$12,000.00	\$1,638.00	\$13,104.00
19	CONSTRUCT 4.5" HIGH STABILITY AC (TYPE C2 PG 70-10-R0)	TN	91	\$400.00	\$36,400.00	\$354.93	\$32,298.63
20	CONSTRUCT 22" AC (TYPE B PG 64-10-R0) BASE COURSE	TN	445	\$200.00	\$89,000.00	\$210.86	\$93,832.70
21	CONSTRUCT 9" PCC PAVEMENT.	CY	134	\$1,000.00	\$134,000.00	\$704.81	\$94,444.54
22	CONSTRUCT 3" OF ASPHALT TREATED PERMEABLE BASE.	TN	45	\$500.00	\$22,500.00	\$317.06	\$14,267.70
23	CONSTRUCT 10" OF CRUSHED AGGREGATE BASE.	CY	149	\$400.00	\$59,600.00	\$280.29	\$41,763.21

Item No	Description	Unit of Measure	Quantity	Mike Bubalo Construction Co., Inc. - Unit Price	Mike Bubalo	Alfaro	Alfaro
					Construction Co., Inc. - Line Total	Communications Construction, Inc. - Unit Price	Communications Construction, Inc. - Line Total
24	CONSTRUCT PCC CURB AND GUTTER TYPE A2 PER CITY OF INDUSTRY STD. PLAN 112 INCLUDING BASE MATERIAL.	LF	720	\$100.00	\$72,000.00	\$84.50	\$60,840.00
25	CONSTRUCT PCC SIDEWALK PER CITY OF INDUSTRY STD. PLAN 115 INCLUDING BASE MATERIAL.	SF	5325	\$20.00	\$106,500.00	\$12.53	\$66,722.25
26	CONSTRUCT CURB RAMP PER CALTRANS STD. PLAN A88A, CASE PER PLAN.	SF	420	\$100.00	\$42,000.00	\$40.21	\$16,888.20
27	CONSTRUCT LOCAL DEPRESSION PER SPPWC STD. PLAN 313-4, CASE E	EA	1	\$6,000.00	\$6,000.00	\$9,720.00	\$9,720.00
28	CONSTRUCT PCC STRUCTURE APPROACH TYPE R (10) PER CALTRANS STD. PLAN B9-2.	EA	3	\$10,000.00	\$30,000.00	\$10,213.67	\$30,641.01
29	CONSTRUCT CURB OPENING CATCH BASIN, W=10' AND H=2", PER SPPWC STD PLAN NO. 300-3.	EA	1	\$10,000.00	\$10,000.00	\$19,440.00	\$19,440.00
30	CONSTRUCT 18" RCP WITH SAND TRENCH BACKFILL.	LF	13	\$2,000.00	\$26,000.00	\$2,328.00	\$30,264.00
31	CONSTRUCT CONCRETE COLLAR PER SPPWC STD. PLAN 380-4	EA	2	\$4,000.00	\$8,000.00	\$4,260.00	\$8,520.00
32	CONSTRUCT MODIFIED MONOLITHIC CATCH BASIN CONNECTION PER SPPWC STD. PLAN 380-2	EA	1	\$25,000.00	\$25,000.00	\$9,108.00	\$9,108.00
33	CONSTRUCT 4" PERFORATED PVC SUBDRAIN WITH TRENCH.	LF	320	\$60.00	\$19,200.00	\$356.50	\$114,080.00
34	CONSTRUCT 6" PVC SUBDRAIN.	LF	465	\$90.00	\$41,850.00	\$511.75	\$237,963.75
35	CONSTRUCT PCC MOISTURE CUT-OFF BARRIER.	LF	80	\$200.00	\$16,000.00	\$333.94	\$26,715.20
36	CONSTRUCT 6" PVC SUBDRAIN CLEANOUT.	EA	1	\$2,000.00	\$2,000.00	\$4,485.00	\$4,485.00
37	UNCLASSIFIED EXCAVATION	CY	770	\$350.00	\$269,500.00	\$223.62	\$172,187.40
38	2' OVEREXCAVATION	CY	834	\$225.00	\$187,650.00	\$419.75	\$350,071.50
39	REGRADE SLOPE PER GEOTECHNICAL REPORT. UNCLASSIFIED FILL (IMPORT)	CY	1770	\$100.00	\$177,000.00	\$276.00	\$488,520.00
40	INSTALL LANDSCAPE PER LANDSCAPE PLANS.	LS	1	\$95,000.00	\$95,000.00	\$103,500.00	\$103,500.00
41	INSTALL IRRIGATION PER IRRIGATION PLANS.	LS	1	\$40,000.00	\$40,000.00	\$42,550.00	\$42,550.00
42	EXISTING LANDSCAPE AND IRRIGATION TO BE MODIFIED AS REQUIRED TO ACCOMMODATE IMPROVEMENTS.	LS	1	\$20,000.00	\$20,000.00	\$17,825.00	\$17,825.00
43	REMOVE AND SALVAGE EXISTING DECORATIVE ROCK AND REINSTALL IN GROUT TO MATCH ADJACENT GRADES.	LS	1	\$15,000.00	\$15,000.00	\$10,647.00	\$10,647.00
44	SIGNING AND STRIPING IMPROVEMENTS	LS	1	\$40,000.00	\$40,000.00	\$42,854.50	\$42,854.50
					\$2,721,870.00		\$3,128,986.37
45	REMOVE AND RELOCATE STREETLIGHT POLE AND REPLACE EXISTING 6' MASTARM WITH 8'.	EA	4	\$10,000.00	\$40,000.00	\$8,244.28	\$32,977.12
46	REPLACE EXISTING STREETLIGHT 6' MASTARM WITH 8'.	EA	1	\$1,000.00	\$1,000.00	\$1,891.50	\$1,891.50
47	FURNISH AND INSTALL NO.5 PULL BOX JENSEN CAT NO. CYN 20 OR APPROVED EQUAL FOR BOX AND JENSEN CAT NO. CYN16-61J OR APPROVED EQUAL FOR COVER WITH "COI ST LIGHT" MARKED ON THE COVER PER CALTRANS STD PLAN NO. RSP ES-8A.	EA	7	\$1,500.00	\$10,500.00	\$2,061.43	\$14,430.01

Item No	Description	Unit of Measure	Quantity	Mike Bubalo Construction Co., Inc. - Unit Price	Mike Bubalo	Alfaro	Alfaro
					Construction Co., Inc. - Line Total	Communications Construction, Inc. - Unit Price	Communications Construction, Inc. - Line Total
48	FURNISH AND INSTALL NO.6 PULL BOX JENSEN CAT NO. HT1730-B FOR BOX JENSEN CAT NO. HT1730-L11-01 FOR COVER OR APPROVED EQUAL PER CALTRANS STD PLAN NO. RSP ES-8A.	EA	2	\$1,750.00	\$3,500.00	\$2,229.50	\$4,459.00
49	FURNISH AND INSTALL 160 W LUMINAIRES COOPER LIGHTING MODEL: ARCH-L-PA3-160-740-U-T3-AP-10MSP-10X OR APPROVED EQUAL.	EA	4	\$1,000.00	\$4,000.00	\$1,358.50	\$5,434.00
50	REPLACE EXISTING PULLBOX COVER WITH MARKING "COI ST LIGHT".	EA	1	\$600.00	\$600.00	\$451.75	\$451.75
51	FURNISH AND INSTALL 3" PVC SCHEDULE 40 CONDUIT MIN.30" DEEP BETWEEN PULLBOXES.	LF	1200	\$50.00	\$60,000.00	\$46.11	\$55,332.00
52	FURNISH AND INSTALL 1" PVC SCHEDULE 40 CONDUIT MIN.30" DEEP BETWEEN PULLBOX AND STREET LIGHT FOUNDATION.	LF	50	\$30.00	\$1,500.00	\$98.54	\$4,927.00
53	FURNISH AND INSTALL 1/0 STRANDED ALUMINUM XHHW WIRE WITHIN 3" PVC CONDUIT PULLBOXES.	LF	3000	\$3.00	\$9,000.00	\$6.96	\$20,880.00
54	FURNISH AND INSTALL #2 STRANDED ALUMINUM XHHW WIRE WITHIN 3" PVC CONDUIT.	LF	1500	\$2.00	\$3,000.00	\$4.01	\$6,015.00
55	FURNISH AND INSTALL #6 STRANDED ALUMINUM XHHW WIRES WITHIN 1" PVC CONDUIT TO HANDHOLE ON THE STREETLIGHT POLE.	LF	1500	\$2.00	\$3,000.00	\$4.01	\$6,015.00
56	FURNISH AND INSTALL FUSES COOPER BUSSMANN KTK-10 WITH FUSE HOLDER OR APPROVED EQUAL AT POLE'S HANDHOLE.	EA	13	\$80.00	\$1,040.00	\$279.50	\$3,633.50
57	FURNISH AND INSTALL 4-WAY SECONDARY BARS (3 CONNECTORS PER PB) UTILCO PED4-350SSP WITHIN PULL BOX.	EA	30	\$400.00	\$12,000.00	\$334.10	\$10,023.00
58	COMPRESSION CONNECTOR CAT NO: ES4W4W ON NEUTRAL WIRE FOR EACH STREETLIGHT POLE.	EA	13	\$20.00	\$260.00	\$58.50	\$760.50
59	INSTALL UBICQUIA WIRELESS STREETLIGHT CONTROLLER(NODE) CAT NO. UBC-30-0-01-NA-01-1-GY ON EACH LUMINAIRE (INCLUDE BUNDLE OF 5 YEAR CONNECTIVITY + 5 YEAR UBIVU SERVICES ) AND WORK WITH UBICQUIA TO MAKE REMOTE MONITORING SYSTEM FUNCTIONAL.	EA	4	\$1,000.00	\$4,000.00	\$1,205.75	\$4,823.00
60	FURNISH AND INSTALL (2) 40A, 1P,120/240 VOLT CIRCUIT BREAKER ON LOAD SIDE OF EXISTING METERING PEDESTAL.	EA	2	\$100.00	\$200.00	\$78.00	\$156.00
61	FURNISH AND INSTALL STREETLIGHT POLE FOUNDATION 2'X2'X4'-6".	EA	4	\$5,000.00	\$20,000.00	\$4,137.25	\$16,549.00
					\$173,600.00		\$188,757.38
					<b>\$2,895,470.00</b>		<b>\$3,317,743.75</b>

**BID BOND**

PROJECT NO. 531

GRAND AVENUE SLOPE RECONSTRUCTION AND PAVEMENT REHABILITATION FROM  
BAKER PARKWAY TO FERRERO PARKWAY

CONTRACT NO. CITY-1531

KNOW ALL MEN BY THESE PRESENTS that we Sol Construction, Inc.

\_\_\_\_\_ as BIDDER, and \_\_\_\_\_  
Everest National Insurance Company, a corporation organized  
and existing under the laws of the State of Delaware, and duly authorized to transact  
business under the laws of the State of California, as SURETY, are held and firmly bound unto  
the City of Industry ("CITY"), in the penal sum of Ten Percent of Total Amount Bid----- [IN WORDS]  
dollars (\$ 10% of Bid), which is 10 percent of the total amount bid by BIDDER to CITY for  
the above-stated project, for the payment of which sum, BIDDER and SURETY agree to be bound,  
jointly and severally, firmly by these presents.

THE CONDITIONS OF THIS OBLIGATION ARE SUCH that, whereas BIDDER is about to submit  
a bid to CITY for the above-stated project, if said bid is rejected, or if said bid is accepted and a  
contract is awarded and entered into by BIDDER in the manner and time specified, then this  
obligation shall be null and void, otherwise it shall remain in full force and effect in favor of CITY.

IN WITNESS WHEREOF the parties hereto have set their names, titles, hands, and seals this  
14th day of February, 2025.

**BIDDER:**

Name: Sol Construction, Inc.

Address: 231 E. Alessandro Blvd. STE A445  
Riverside, CA 92508

By: *Manuel Andrade*

Signature: *Manuel Andrade*

Title: President

**SURETY:**

Name: Everest National Insurance Company

Address: 100 Everest Way, Warren Corporate Center  
Warren, NJ 07059

By: Rebecca Haas-Bates

Signature: *Rebecca Haas-Bates*

Title: Attorney-in-Fact

**Note:**

- The signature on this form (Bid Bond, Page A-12) must be acknowledged before a Notary Public with an Acknowledgement Form attached.
- If any person is signing as attorney-in-fact, evidence of the authority for that must be attached as well.

**CALIFORNIA ALL-PURPOSE ACKNOWLEDGMENT**

**CIVIL CODE § 1189**

A notary public or other officer completing this certificate verifies only the identity of the individual who signed the document to which this certificate is attached, and not the truthfulness, accuracy, or validity of that document.

State of California )  
County of Orange )

On 02/14/2025 before me, Alma Karen Hernandez, Notary Public  
*Date Here Insert Name and Title of the Officer*

personally appeared Rebecca Haas-Bates  
*Name(s) of Signer(s)*

who proved to me on the basis of satisfactory evidence to be the person(s) whose name(s) is/are subscribed to the within instrument and acknowledged to me that he/she/they executed the same in his/her/their authorized capacity(ies), and that by his/her/their signature(s) on the instrument the person(s), or the entity upon behalf of which the person(s) acted, executed the instrument.

I certify under PENALTY OF PERJURY under the laws of the State of California that the foregoing paragraph is true and correct.

WITNESS my hand and official seal.

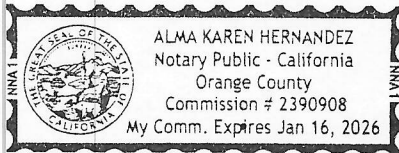

Signature [Handwritten Signature]  
*Signature of Notary Public*

*Place Notary Seal Above*

**OPTIONAL**

*Though this section is optional, completing this information can deter alteration of the document or fraudulent reattachment of this form to an unintended document.*

**Description of Attached Document**

Title or Type of Document: Bid Bond Document Date: 02/14/2025

Number of Pages: One (1) Signer(s) Other Than Named Above: \_\_\_\_\_

**Capacity(ies) Claimed by Signer(s)**

Signer's Name: Rebecca Haas-Bates

- Corporate Officer — Title(s): \_\_\_\_\_
- Partner —  Limited  General
- Individual  Attorney in Fact
- Trustee  Guardian or Conservator
- Other: \_\_\_\_\_

Signer Is Representing: Everest National Insurance Company

Signer's Name: \_\_\_\_\_

- Corporate Officer — Title(s): \_\_\_\_\_
- Partner —  Limited  General
- Individual  Attorney in Fact
- Trustee  Guardian or Conservator
- Other: \_\_\_\_\_

Signer Is Representing: \_\_\_\_\_

**CALIFORNIA ALL-PURPOSE ACKNOWLEDGMENT**

**CIVIL CODE § 1189**

A notary public or other officer completing this certificate verifies only the identity of the individual who signed the document to which this certificate is attached, and not the truthfulness, accuracy, or validity of that document.

State of California )  
County of Riverside )  
On 2/19/25 before me, Crystal Cervantes, Notary Public,  
Date Here Insert Name and Title of the Officer  
personally appeared Manuel Andrade  
Name(s) of Signer(s)

who proved to me on the basis of satisfactory evidence to be the person(s) whose name(s) is/are subscribed to the within instrument and acknowledged to me that he/she/they executed the same in his/her/their authorized capacity(ies), and that by his/her/their signature(s) on the instrument the person(s), or the entity upon behalf of which the person(s) acted, executed the instrument.

I certify under PENALTY OF PERJURY under the laws of the State of California that the foregoing paragraph is true and correct.

WITNESS my hand and official seal.

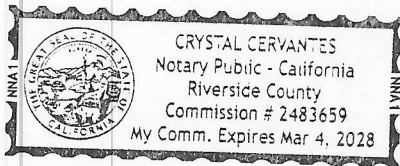

Signature [Signature]  
Signature of Notary Public

Place Notary Seal Above

**OPTIONAL**

Though this section is optional, completing this information can deter alteration of the document or fraudulent reattachment of this form to an unintended document.

**Description of Attached Document**

Title or Type of Document: Bid Bond

Document Date: \_\_\_\_\_ Number of Pages: \_\_\_\_\_

Signer(s) Other Than Named Above: \_\_\_\_\_

**Capacity(ies) Claimed by Signer(s)**

Signer's Name: \_\_\_\_\_

Corporate Officer — Title(s): \_\_\_\_\_

Partner —  Limited  General

Individual  Attorney in Fact

Trustee  Guardian or Conservator

Other: \_\_\_\_\_

Signer Is Representing: \_\_\_\_\_

Signer's Name: \_\_\_\_\_

Corporate Officer — Title(s): \_\_\_\_\_

Partner —  Limited  General

Individual  Attorney in Fact

Trustee  Guardian or Conservator

Other: \_\_\_\_\_

Signer Is Representing: \_\_\_\_\_



POWER OF ATTORNEY
EVEREST REINSURANCE COMPANY and EVEREST NATIONAL INSURANCE COMPANY

KNOW ALL PERSONS BY THESE PRESENTS: That Everest Reinsurance Company and Everest National Insurance Company, corporations of the State of Delaware ("Company") having their principal offices located at Warren Corporate Center, 100 Everest Way, Warren, New Jersey, 07059, do hereby nominate, constitute, and appoint:

William Syrkin, Rebecca Haas-Bates, Megan Hilke, Richard Adair

its true and lawful Attorney(s)-in-fact to make, execute, attest, seal and deliver for and on its behalf, as surety, and as its act and deed, where required, any and all bonds and undertakings in the nature thereof, for the penal sum of no one of which is in any event to exceed UNLIMITED, reserving for itself the full power of substitution and revocation.

Such bonds and undertakings, when duly executed by the aforesaid Attorney(s)-in-fact shall be binding upon the Company as fully and to the same extent as if such bonds and undertakings were signed by the President and Secretary of the Company and sealed with its corporate seal.

This Power of Attorney is granted and is signed by facsimile under and by the authority of the following Resolutions adopted by the Board of Directors of Company ("Board") on April 21, 2016:

RESOLVED, that the President, any Executive Vice President, and any Senior Vice President are hereby appointed by the Board as authorized to make, execute, seal and deliver for and on behalf of the Company, any and all bonds, undertakings, contracts or obligations in surety or co-surety with others and that the Secretary or any Assistant Secretary of the Company be and that each of them hereby is authorized to attest to the execution of any such bonds, undertakings, contracts or obligations in surety or co-surety and attach thereto the corporate seal of the Company.

RESOLVED, FURTHER, that the President, any Executive Vice President, and any Senior Vice President are hereby authorized to execute powers of attorney qualifying the attorney named in the given power of attorney to execute, on behalf of the Company, bonds and undertakings in surety or co-surety with others, and that the Secretary or any Assistant Secretary of the Company be, and that each of them is hereby authorized to attest the execution of any such power of attorney, and to attach thereto the corporate seal of the Company.

RESOLVED, FURTHER, that the signature of such officers named in the preceding resolutions and the corporate seal of the Company may be affixed to such powers of attorney or to any certificate relating thereto by facsimile, and any such power of attorney or certificate bearing such facsimile signatures or facsimile seal shall be thereafter valid and binding upon the Company with respect to any bond, undertaking, contract or obligation in surety or co-surety with others to which it is attached.

IN WITNESS WHEREOF, Everest Reinsurance Company and Everest National Insurance Company have caused their corporate seals to be affixed hereto, and these presents to be signed by their duly authorized officers this 10th day of October 2023.



Everest Reinsurance Company and Everest National Insurance Company

[Handwritten signature of Anthony Romano]

By: Anthony Romano, Senior Vice President

On this 22nd of March 2023, before me personally came Anthony Romano, known to me, who, being duly sworn, did execute the above instrument; that he knows the seal of said Company; that the seal affixed to the aforesaid instrument is such corporate seal and was affixed thereto; and that he executed said instrument by like order.

LINDA ROBINS
Notary Public, State of New York
No 01R06239736
Qualified in Queens County
Term Expires April 25, 2027

[Handwritten signature of Linda Robins]

Linda Robins, Notary Public

I, Sylvia Semerdjian, Assistant Secretary of Everest Reinsurance Company and Everest National Insurance Company do hereby certify that I have compared the foregoing copy of the Power of Attorney and affidavit, and the copy of the Section of the bylaws and resolutions of said Corporation as set forth in said Power of Attorney, with the ORIGINALS ON FILE IN THE HOME OFFICE OF SAID CORPORATION, and that the same are correct transcripts thereof, and of the whole of the said originals, and that the said Power of Attorney has not been revoked and is now in full force and effect.

IN WITNESS WHEREOF, I have hereunto set my hand and affixed the seal of said Company, this 14th day of February 2025.



[Handwritten signature of Sylvia Semerdjian]

By: Sylvia Semerdjian, Assistant Secretary

CITY OF INDUSTRY  
15625 Mayor Dave Way  
City of Industry, CA 91744

**ADDENDUM NO. 1**  
TO THE CONTRACT DOCUMENTS FOR:

CITY OF INDUSTRY  
CONTRACT NO. CITY-1531

GRAND AVENUE SLOPE RECONSTRUCTION AND PAVEMENT REHABILITATION  
FROM BAKER PARKWAY TO FERRERO PARKWAY

January 30, 2025

**This Addendum forms a part of the Contract Documents and modifies the original bid documents. Acknowledge receipt of the Addendum on PlanetBids™ per Bidders Information Sheet of the Contract Documents and Specifications. Failure to do so will result in the bid being deemed non-responsive.**

**Note:** It is the responsibility of all bidders to notify all subcontractors from whom they request bids and from whom they accept bids of all changes contained in this addendum.

All other terms and conditions remain unchanged.

**ADDENDUM NO. 1 CONTENTS**

**I. PLANETBIDS QUESTIONS AND ANSWERS**

\*\*\*\*\*

**I. PLANETBIDS QUESTIONS & ANSWERS**

1. **QUESTION: We're currently reviewing the landscape and irrigation plan sheets for this project, but we're having some difficulty reading them due to markings obscuring key details and the absence of scale measurements. Would you happen to have clearer versions of these plans, or perhaps a more legible set that we could review?**  
*ANSWER: The plan included with the planset is the most legible version available to the city.*
2. **QUESTION: Is there a self-performance minimum for prime contractors?**  
*ANSWER: Self-Performance requirements for prime contractors shall be per Subsection 3-2 of the Greenbook Specifications.*
3. **QUESTION: I was reviewing the landscape plans for the above-mentioned project, and came across the abbreviation "N.A.P." Could you please clarify what this stands for?**  
*ANSWER: N.A.P. stand for 'Not a Part', therefore the area clouded will not be part of the project.*

**\*\* END OF ADDENDUM NO. 1 \*\***

Acknowledged by Manuel Andrade  
[Signature]

CITY OF INDUSTRY  
15625 Mayor Dave Way  
City of Industry, CA 91744

**ADDENDUM NO. 2**  
TO THE CONTRACT DOCUMENTS FOR:

CITY OF INDUSTRY  
CONTRACT NO. CITY-1531

GRAND AVENUE SLOPE RECONSTRUCTION AND PAVEMENT REHABILITATION  
FROM BAKER PARKWAY TO FERRERO PARKWAY

February 20, 2025

**This Addendum forms a part of the Contract Documents and modifies the original bid documents. Acknowledge receipt of the Addendum on PlanetBids™ per Bidders Information Sheet of the Contract Documents and Specifications. Failure to do so will result in the bid being deemed non-responsive.**

**Note:** It is the responsibility of all bidders to notify all subcontractors from whom they request bids and from whom they accept bids of all changes contained in this addendum.

All other terms and conditions remain unchanged.

**ADDENDUM NO. 2 CONTENTS**

**I. SPECIFICATIONS**

\*\*\*\*\*

**I. SPECIFICATIONS**

1. **NOTICE INVITING SEALED BIDS, PAGE A-1**, change the date of receiving bids to **Thursday, March 20, 2025 at 10:00 a.m.** via the City of Industry's PlanetBids™ vendor portal.

**NOTE**

**Please note the City is working diligently to address all of the posted questions and will be releasing subsequent addenda to clarify the issues raised, with sufficient time to adjust bids.**

**\*\* END OF ADDENDUM NO. 2 \*\***

*Acknowledged by Manuel Andrade*



**SHADING INDICATES  
CHANGES MADE IN  
ADDENDUM NO. 3**

**PLEASE NOTE THAT UNIT  
PRICES SHALL ONLY BE  
ENTERED ONLINE WITHIN THE  
PLANETBIDS™ SOFTWARE. BID  
SCHEDULE PAGES C-4  
THROUGH C-13 ARE REQUIRED  
TO BE SUBMITTED AS A PDF  
UPLOAD VIA PLANETBIDS PER  
CHECKLIST ON PAGE B-6**

**SECTION C  
BID SCHEDULE  
FOR  
CITY OF INDUSTRY  
PROJECT NO. 531**

**GRAND AVENUE SLOPE RECONSTRUCTION AND PAVEMENT REHABILITATION  
FROM BAKER PARKWAY TO FERRERO PARKWAY**

CONTRACT NO. CITY-1531

BIDDER: Sol Construction, Inc.

Hereby proposes to construct the above-named project in accordance with the plans and specifications for the following prices:

**SCHEDULE OF WORK ITEMS**

NO.	DESCRIPTION	APPROX. QTY	UNIT MEAS.	UNIT PRICE	TOTAL
<b>SCHEDULE A - STREET, STORM DRAIN, GRADING, SIGNING &amp; STRIPING &amp; LANDSCAPING</b>					
1.	MOBILIZATION	1	LS		
2.	PREPARATION AND IMPLEMENTATION OF EROSION CONTROL PLANS	1	LS		
3.	TRAFFIC CONTROL	1	LS		
4.	CLEARING AND GRUBBING	1	LS		
5.	COLDMILL AND REMOVE EXISTING AC PAVEMENT. DEPTH 2"	6,811	SY		
6.	SAWCUT AND REMOVE EXISTING AC PAVEMENT AND BASE MATERIAL,	3,205	SF		
7.	SAWCUT AND REMOVE EXISTING PCC PAVEMENT AND BASE MATERIAL,	569	SY		
8.	SAWCUT AND REMOVE EXISTING PCC CURB AND GUTTER INCLUDING BASE.	720	LF		
9.	SAWCUT AND REMOVE EXISTING PCC SIDEWALK INCLUDING BASE.	5,325	SF		
10.	SAWCUT AND REMOVE EXISTING CURB RAMP.	315	SF		
11.	SAWCUT AND REMOVE EXISTING CATCH BASIN, LOCAL DEPRESSION AND PORTION OF REINFORCED CONCRETE PIPE.	1	EA		
12.	SAWCUT AND REMOVE EXISTING PCC BRIDGE APPROACH SLAB, INCLUDING REINFORCEMENT.	3	EA		

**SHADING INDICATES  
CHANGES MADE IN  
ADDENDUM NO. 3**

NO.	DESCRIPTION	APPROX. QTY	UNIT MEAS.	UNIT PRICE	TOTAL
13.	ADJUST PULLBOX OR UTILITY COVER AND FRAME TO FINISHED GRADE.	3	EA		
14.	ADJUST BLOWOFF AND COVER TO FINISHED GRADE.	3	EA		
15.	ADJUST FIRE HYDRANT TO FINISHED GRADE.	1	EA		
16.	CONSTRUCT 2-INCH THICK (C2 PG 64-10-R0) AC OVERLAY.	782	TN		
17.	CONSTRUCT STREET PAVEOUT AC PER CITY OF INDUSTRY STD. PLAN NO. 111.	8	TN		
18.	CONSTRUCT STREET PAVEOUT COMPACTED AGGREGATE BASE PER CITY OF INDUSTRY STD. PLAN NO. 111.	8	CY		
19.	CONSTRUCT 4.5" HIGH STABILITY AC (TYPE C2 PG 70-10-R0)	91	TN		
20.	CONSTRUCT 22" AC (TYPE B PG 64-10-R0) BASE COURSE	445	TN		
21.	CONSTRUCT 9" PCC PAVEMENT.	134	CY		
22.	CONSTRUCT 3" OF ASPHALT TREATED PERMEABLE BASE.	45	TN		
23.	CONSTRUCT 10" OF CRUSHED AGGREGATE BASE.	149	CY		
24.	CONSTRUCT PCC CURB AND GUTTER TYPE A2 PER CITY OF INDUSTRY STD. PLAN 112 INCLUDING BASE MATERIAL.	720	LF		
25.	CONSTRUCT PCC SIDEWALK PER CITY OF INDUSTRY STD. PLAN 115 INCLUDING BASE MATERIAL.	5,325	SF		
26.	CONSTRUCT CURB RAMP PER CALTRANS STD. PLAN A88A, CASE PER PLAN.	420	SF		
27.	CONSTRUCT LOCAL DEPRESSION PER SPPWC STD. PLAN 313-4, CASE E	1	EA		
28.	CONSTRUCT PCC STRUCTURE APPROACH TYPE R (10) PER CALTRANS STD. PLAN B9-2.	3	EA		
29.	CONSTRUCT CURB OPENING CATCH BASIN, W=10' AND H=2", PER SPPWC STD PLAN NO. 300-3.	1	EA		
30.	CONSTRUCT 18" RCP WITH SAND TRENCH BACKFILL.	13	LF		
31.	CONSTRUCT CONCRETE COLLAR PER SPPWC STD. PLAN 380-4	2	EA		
32.	CONSTRUCT MODIFIED MONOLITHIC CATCH BASIN CONNECTION PER SPPWC STD. PLAN 380-2	1	EA		
33.	CONSTRUCT 4" PERFORATED PVC SUBDRAIN WITH TRENCH.	320	LF		
34.	CONSTRUCT 6" PVC SUBDRAIN.	465	LF		
35.	CONSTRUCT PCC MOISTURE CUT-OFF BARRIER.	80	LF		

**SHADING INDICATES  
CHANGES MADE IN  
ADDENDUM NO. 3**

NO.	DESCRIPTION	APPROX. QTY	UNIT MEAS.	UNIT PRICE	TOTAL
36.	CONSTRUCT 6" PVC SUBDRAIN CLEANOUT.	1	EA		
37.	UNCLASSIFIED EXCAVATION	770	CY		
38.	2' OVEREXCAVATION	834	CY		
39.	REGRADE SLOPE PER GEOTECHNICAL REPORT. UNCLASSIFIED FILL (IMPORT)	1,770	CY		
40.	INSTALL LANDSCAPE PER LANDSCAPE PLANS.	1	LS		
41.	INSTALL IRRIGATION PER IRRIGATION PLANS.	1	LS		
42.	EXISTING LANDSCAPE AND IRRIGATION TO BE MODIFIED AS REQUIRED TO ACCOMMODATE IMPROVEMENTS.	1	LS		
43.	REMOVE AND SALVAGE EXISTING DECORATIVE ROCK AND REINSTALL IN GROUT TO MATCH ADJACENT GRADES.	1	LS		
44.	SIGNING AND STRIPING IMPROVEMENTS	1	LS		
<b>SCHEDULE B – STREET LIGHTING</b>					
45.	REMOVE AND RELOCATE STREETLIGHT POLE AND REPLACE EXISTING 6' MASTARM WITH 8'.	4	EA		
46.	REPLACE EXISTING STREETLIGHT 6' MASTARM WITH 8'.	1	EA		
47.	FURNISH AND INSTALL NO.5 PULL BOX JENSEN CAT NO. CYN 20 OR APPROVED EQUAL FOR BOX AND JENSEN CAT NO. CYN16-61J OR APPROVED EQUAL FOR COVER WITH "COI ST LIGHT" MARKED ON THE COVER PER CALTRANS STD PLAN NO. RSP ES-8A.	7	EA		
48.	FURNISH AND INSTALL NO.6 PULL BOX JENSEN CAT NO. HT1730-B FOR BOX JENSEN CAT NO. HT1730-L11-01 FOR COVER OR APPROVED EQUAL PER CALTRANS STD PLAN NO. RSP ES-8A.	2	EA		
49.	FURNISH AND INSTALL 160 W LUMINAIRES COOPER LIGHTING MODEL: ARCH-L-PA3-160-740-U-T3-AP-10MSP-10X OR APPROVED EQUAL.	4	EA		
50.	REPLACE EXISTING PULLBOX COVER WITH MARKING "COI ST LIGHT".	1	EA		
51.	FURNISH AND INSTALL 3" PVC SCHEDULE 40 CONDUIT MIN.30" DEEP BETWEEN PULLBOXES.	1,200	LF		
52.	FURNISH AND INSTALL 1" PVC SCHEDULE 40 CONDUIT MIN.30" DEEP BETWEEN PULLBOX AND STREET LIGHT FOUNDATION.	50	LF		

**SHADING INDICATES  
CHANGES MADE IN  
ADDENDUM NO. 3**

NO.	DESCRIPTION	APPROX. QTY	UNIT MEAS.	UNIT PRICE	TOTAL
53.	FURNISH AND INSTALL 1/0 STRANDED ALUMINUM XHHW WIRE WITHIN 3" PVC CONDUIT PULLBOXES.	3,000	LF		
54.	FURNISH AND INSTALL #2 STRANDED ALUMINUM XHHW WIRE WITHIN 3" PVC CONDUIT.	1,500	LF		
55.	FURNISH AND INSTALL #6 STRANDED ALUMINUM XHHW WIRES WITHIN 1" PVC CONDUIT TO HANDHOLE ON THE STREETLIGHT POLE.	1,500	LF		
56.	FURNISH AND INSTALL FUSES COOPER BUSSMANN KTK-10 WITH FUSE HOLDER OR APPROVED EQUAL AT POLE'S HANDHOLE.	13	EA		
57.	FURNISH AND INSTALL 4-WAY SECONDARY BARS (3 CONNECTORS PER PB) UTILCO PED4-350SSP WITHIN PULL BOX.	30	EA		
58.	FURNISH AND INSTALL BURNDY INSULATED AL SERVICE ENTRANCE COMPRESSION CONNECTOR CAT NO: ES4W4W ON NEUTRAL WIRE FOR EACH STREETLIGHT POLE.	13	EA		
59.	INSTALL UBICQUIA WIRELESS STREETLIGHT CONTROLLER(NODE) CAT NO. UBC-30-0-01-NA-01-1-GY ON EACH LUMINAIRE (INCLUDE BUNDLE OF 5 YEAR CONNECTIVITY + 5 YEAR UBIVU SERVICES ) AND WORK WITH UBICQUIA TO MAKE REMOTE MONITORING SYSTEM FUNCTIONAL.	4	EA		
60.	FURNISH AND INSTALL (2) 40A, 1P, 120/240 VOLT CIRCUIT BREAKER ON LOAD SIDE OF EXISTING METERING PEDESTAL.	2	EA		
61.	FURNISH AND INSTALL STREETLIGHT POLE FOUNDATION 2'X2'X4'-6".	4	EA		
GRAND TOTAL					

I hereby certify that on March 20, 2025, Manuel Andrade  
(Print Name)

examined the site of the proposed work, and the undersigned, fully understands the scope of work and has checked carefully all words and figures inserted in the Bid Schedule.

**SHADING INDICATES  
CHANGES MADE IN  
ADDENDUM NO. 3**

By:

Sol Construction, Inc.

CONTRACTOR NAME

mandrade@sol-construction.com

EMAIL ADDRESS

1000012204

DIR #

Manuel Andrade

PRINT NAME



SIGNATURE

**BID RESULTS**

CITY OF INDUSTRY  
PROJECT NO. 531

GRAND AVENUE SLOPE RECONSTRUCTION AND PAVEMENT REHABILITATION FROM  
BAKER PARKWAY TO FERRERO PARKWAY

CONTRACT NO. CITY-1531

**PLEASE NOTE:** This page was intentionally left blank. After the bid has been awarded, it will be replaced with the awardee's Bid Results from PlanetBids™

## BIDDER'S INFORMATION SHEET

- **Receipt of any addenda shall be acknowledged only online through the PlanetBids™ software.**

RETENTION MONEY OPTION: Please initial one of the following options.

1. I will provide securities (escrow account) in lieu of monies to be withheld to  
(Initials) ensure performance under the contract as per Section D63, General Provisions.
- 475   2. I will not provide securities in lieu of monies to ensure performance under the  
(Initials) contract. I understand retention will be held by the City of Industry per Section  
D22, General Provisions.

The undersigned, as bidder, declares as follows:

1. The only persons or parties interested in this proposal as principals are those named herein;
2. This proposal is made without collusion with any other person, firm or corporation;
3. We have carefully examined the location of the proposed work, the attached proposed form of contract, and the plans therein referred to; and
4. We propose and agree, if this Proposal is accepted, that we will contract with the City of Industry in the form of the copy of the contract attached hereto;
5. We will provide all necessary machinery, tools, apparatus and other means of construction and/or maintenance;
6. We will do all the work and furnish all the materials specified in the contract, in the manner and time therein prescribed, and according to the requirements of the CITY Engineer as therein set forth; and
7. This bid is sufficient to allow us to comply with all applicable local, state, and federal laws or regulations governing the labor or services to be provided; and
8. We will take in full payment therefore in the amounts shown on the Bid Schedule.

IN WITNESS WHEREOF, Bidder executes and submits this proposal with the names, titles, hands, and seals of all aforementioned principals this 19<sup>th</sup> day of March, 2025.

The undersigned declares under penalty of perjury under the laws of the State of California that the representations made hereto are true and correct.

Sol Construction, Inc.  
Bidder

Manuel Andrade  
Signature

231 E. Alessandro Blvd #A445  
Mailing Address

Manuel Andrade  
Print Name

Riverside, CA. 92508  
City/State/Zip

President  
Title

(951) 653-1155  
Telephone

812330 A General  
License No./Class

(951) 653-1115  
Fax

9-30-2025  
Expiration Date

Select **one** of the following: The Bidder is a:

- Partnership
- Corporation
- Individual

The names of all persons, firms or corporations interested in this bid are: (See Section B, Page B-2, Item 4 - Signature of Bid).

**AFFIX CORPORATE SEAL**

Manuel Andrade  
\_\_\_\_\_  
\_\_\_\_\_  
\_\_\_\_\_

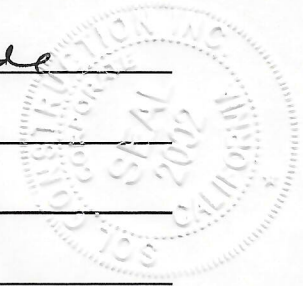

**Note:**

- The signature on this form (Bidders Information Sheet, Pages C-9 and C-10) must be acknowledged before a Notary Public with an Acknowledgement Form attached.
- If any person is signing as attorney-in-fact, evidence of the authority for that must be attached as well.

Notary Certificate  
Attached

# California Jurat Certificate

A notary public or other officer completing this certificate verifies only the identity of the individual who signed the document to which this certificate is attached, and not the truthfulness, accuracy, or validity of that document.

**State of California**

County of Riverside } s.s.

Subscribed and sworn to (or affirmed) before me on this 19 day of March,  
Month

2025, by Manuel Salvador Andrade and  
Name of Signer (1)

\_\_\_\_\_,  
Name of Signer (2) proved to me on the basis of

satisfactory evidence to be the person(s) who appeared before me.

Debra Mello  
Signature of Notary Public

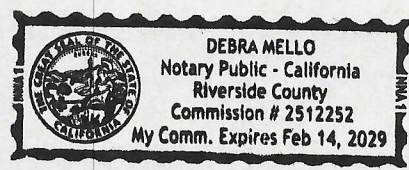

For other required information (Notary Name, Commission No. etc.)

Seal

**OPTIONAL INFORMATION**

*Although the information in this section is not required by law, it could prevent fraudulent removal and reattachment of this jurat to an unauthorized document and may prove useful to persons relying on the attached document.*

**Description of Attached Document**

The certificate is attached to a document titled/for the purpose of

Bidders Information Sheet

containing \_\_\_\_\_ pages, and dated \_\_\_\_\_

Additional Information
<b>Method of Affiant Identification</b>  Proved to me on the basis of satisfactory evidence: <input type="radio"/> form(s) of identification <input type="radio"/> credible witness(es)
Notarial event is detailed in notary journal on:  Page # _____ Entry # _____
Notary contact: _____
Other  <input type="checkbox"/> Affiant(s) Thumbprint(s) <input type="checkbox"/> Describe: _____  _____

8  
1A  
28  
REI

CONTRACTOR'S LICENSE AFFIDAVIT

STATE OF CALIFORNIA )  
COUNTY OF LOS ANGELES )

CITY OF INDUSTRY  
PROJECT NO. 531

GRAND AVENUE SLOPE RECONSTRUCTION AND PAVEMENT REHABILITATION FROM  
BAKER PARKWAY TO FERRERO PARKWAY

CONTRACT NO. CITY-1531

Manuel Andrade, being first duly sworn, deposes and says that  
Name

he or she is President, of Sol Construction, Inc.,  
Title Name of Firm

812330 License Number A-General Classification

9-30-2025  
Expiration Date

The party making the foregoing bid, is a licensed contractor and understands the information shown above shall be included with the bid, and understands that any bid not containing this information, or if this information is subsequently proven to be false, shall be considered non-responsive and shall be rejected by the CITY OF INDUSTRY.

I certify under penalty of perjury under the laws of the State of California that the foregoing is true and correct.

3-19-25  
DATE

[Signature]  
SIGNATURE

Note:

- The signature on this form (Contractor's License Affidavit, Page C-11) must be acknowledged before a Notary Public with an Acknowledgement Form attached.
- If any person is signing as attorney-in-fact, evidence of the authority for that must be attached as well.

# California Jurat Certificate

A notary public or other officer completing this certificate verifies only the identity of the individual who signed the document to which this certificate is attached, and not the truthfulness, accuracy, or validity of that document.

State of California

County of Riverside

} s.s.

Subscribed and sworn to (or affirmed) before me on this 19 day of March,  
Month

20 25, by Mmanuel Salvador Andrade and  
Name of Signer (1)

[Signature], proved to me on the basis of  
Name of Signer (2)

satisfactory evidence to be the person(s) who appeared before me.

[Signature]  
Signature of Notary Public

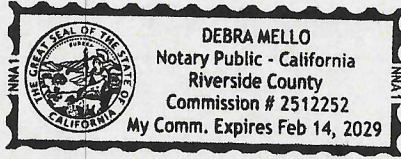

For other required information (Notary Name, Commission No. etc.)

Seal

### OPTIONAL INFORMATION

Although the information in this section is not required by law, it could prevent fraudulent removal and reattachment of this jurat to an unauthorized document and may prove useful to persons relying on the attached document.

### Description of Attached Document

The certificate is attached to a document titled/for the purpose of

Contractors License Affidavit

containing \_\_\_\_\_ pages, and dated \_\_\_\_\_

Additional Information
Method of Affiant Identification
Proved to me on the basis of satisfactory evidence: <input type="radio"/> form(s) of identification <input type="radio"/> credible witness(es)
Notarial event is detailed in notary journal on: Page # _____ Entry # _____
Notary contact: _____
Other
<input type="checkbox"/> Affiant(s) Thumbprint(s) <input type="checkbox"/> Describe: _____

**BIDDER'S LIST OF CONSTRUCTION TRADES**

In submitting this bid for the following project:

CITY OF INDUSTRY  
PROJECT NO. 531

GRAND AVENUE SLOPE RECONSTRUCTION AND PAVEMENT REHABILITATION FROM  
BAKER PARKWAY TO FERRERO PARKWAY

CONTRACT NO. CITY-1531

Sol Construction, Inc. \_\_\_\_\_ certifies that:  
Bidder

The following listed construction trades will be used in the work.

- |  |   |   |  |
|--|---|---|--|
| <input type="checkbox"/> ASBESTOS            | <input type="checkbox"/> BOILERMAKER              | <input type="checkbox"/> BRICKLAYERS              | <input checked="" type="checkbox"/> CARPENTERS   |
| <input type="checkbox"/> CARPET/LINOLEUM     | <input checked="" type="checkbox"/> CEMENT MASONS | <input type="checkbox"/> DRYWALL FINISHER         | <input type="checkbox"/> DRYWALL/LATHERS         |
| <input type="checkbox"/> ELECTRICIANS        | <input type="checkbox"/> ELEVATOR MECHANIC        | <input type="checkbox"/> GLAZIERS                 | <input checked="" type="checkbox"/> IRON WORKERS |
| <input checked="" type="checkbox"/> LABORERS | <input type="checkbox"/> MILLWRIGHTS              | <input checked="" type="checkbox"/> OPERATING ENG | <input type="checkbox"/> PAINTERS                |
| <input type="checkbox"/> PILE DRIVERS        | <input type="checkbox"/> PIPE TRADES              | <input type="checkbox"/> PLASTERERS               | <input type="checkbox"/> ROOFERS                 |
| <input type="checkbox"/> SHEET METAL         | <input type="checkbox"/> SOUND/COMM               | <input type="checkbox"/> SURVEYORS                | <input type="checkbox"/> TEAMSTER                |
| <input type="checkbox"/> TILE WORKERS        |   |   |  |



\_\_\_\_\_  
Signature of Authorized  
Representative of Bidder

NON-COLLUSION DECLARATION

CITY OF INDUSTRY  
PROJECT NO. 531

GRAND AVENUE SLOPE RECONSTRUCTION AND PAVEMENT REHABILITATION FROM  
BAKER PARKWAY TO FERRERO PARKWAY

CONTRACT NO. CITY-1531

CONTRACTOR:

Sol Construction, Inc.

BUSINESS ADDRESS:

231 E. Alessandro Blvd #A445  
Riverside CA 92508

In submitting this bid for the project:

I, Manuel Andrade, state that I have not directly or indirectly,  
(Name)  
entered into any agreement, participated in any collusion or otherwise taken any action in restraint  
of free competitive bidding in connection with the project.

I do hereby certify under penalty of perjury under the laws of the State of California that the  
foregoing is true and correct. Executed at Riverside  
California, this 19<sup>th</sup> day of March, 2025

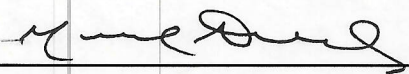

SIGNATURE

Note:

- The signature on this form (Non-Collusion Declaration, Page C-13) must be acknowledged before a Notary Public with an Acknowledgement Form attached.
- If any person is signing as attorney-in-fact, evidence of the authority for that must be attached as well.



City of Industry  
 Bid Results for Project GRAND AVENUE SLOPE RECONSTRUCTION AND PAVEMENT REHABILITATION FROM BAKER  
 PARKWAY TO FERRERO PARKWAY (CITY-1531)  
 Issued on 01/15/2025  
 Bid Due on March 20, 2025 10:00 AM (PDT)  
 Line Totals (Unit Price \* Quantity)

Item No	Description	Unit of Measure	Quantity	Sol Construction, Inc - Unit Price	Sol Construction, Inc - Line Total
1	MOBILIZATION	LS	1	\$185,000.00	\$185,000.00
2	PREPARATION AND IMPLEMENTATION OF EROSION CONTROL PLANS	LS	1	\$18,075.00	\$18,075.00
3	TRAFFIC CONTROL	LS	1	\$66,275.00	\$66,275.00
4	CLEARING AND GRUBBING	LS	1	\$68,600.00	\$68,600.00
5	COLDMILL AND REMOVE EXISTING AC PAVEMENT. DEPTH 2"	SY	6811	\$8.00	\$54,488.00
6	SAWCUT AND REMOVE EXISTING AC PAVEMENT AND BASE MATERIAL,	SF	3205	\$11.00	\$35,255.00
7	SAWCUT AND REMOVE EXISTING PCC PAVEMENT AND BASE MATERIAL,	SY	569	\$96.00	\$54,624.00
8	SAWCUT AND REMOVE EXISTING PCC CURB AND GUTTER INCLUDING BASE.	LF	720	\$18.00	\$12,960.00
9	SAWCUT AND REMOVE EXISTING PCC SIDEWALK INCLUDING BASE.	SF	5325	\$5.00	\$26,625.00
10	SAWCUT AND REMOVE EXISTING CURB RAMP.	SF	315	\$43.00	\$13,545.00
11	SAWCUT AND REMOVE EXISTING CATCH BASIN, LOCAL DEPRESSION AND PORTION OF REINFORCED CONCRETE PIPE.	EA	1	\$30,000.00	\$30,000.00
12	SAWCUT AND REMOVE EXISTING PCC BRIDGE APPROACH SLAB, INCLUDING REINFORCEMENT.	EA	3	\$10,000.00	\$30,000.00
13	ADJUST PULLBOX OR UTILITY COVER AND FRAME TO FINISHED GRADE.	EA	3	\$600.00	\$1,800.00
14	ADJUST BLOWOFF AND COVER TO FINISHED GRADE.	EA	3	\$600.00	\$1,800.00
15	ADJUST FIRE HYDRANT TO FINISHED GRADE.	EA	1	\$8,160.00	\$8,160.00
16	CONSTRUCT 2-INCH THICK (C2 PG 64-10-R0) AC OVERLAY.	TN	782	\$199.00	\$155,618.00
17	CONSTRUCT STREET PAVEOUT AC PER CITY OF INDUSTRY STD. PLAN NO. 111.	TN	8	\$669.00	\$5,352.00
18	CONSTRUCT STREET PAVEOUT COMPACTED AGGREGATE BASE PER CITY OF INDUSTRY STD. PLAN NO. 111.	CY	8	\$538.00	\$4,304.00
19	CONSTRUCT 4.5" HIGH STABILITY AC (TYPE C2 PG 70-10-R0)	TN	91	\$257.00	\$23,387.00
20	CONSTRUCT 22" AC (TYPE B PG 64-10-R0) BASE COURSE	TN	445	\$241.00	\$107,245.00
21	CONSTRUCT 9" PCC PAVEMENT.	CY	134	\$488.00	\$65,392.00
22	CONSTRUCT 3" OF ASPHALT TREATED PERMEABLE BASE.	TN	45	\$393.00	\$17,685.00
23	CONSTRUCT 10" OF CRUSHED AGGREGATE BASE.	CY	149	\$160.00	\$23,840.00
24	CONSTRUCT PCC CURB AND GUTTER TYPE A2 PER CITY OF INDUSTRY STD. PLAN 112 INCLUDING BASE MATERIAL.	LF	720	\$64.00	\$46,080.00
25	CONSTRUCT PCC SIDEWALK PER CITY OF INDUSTRY STD. PLAN 115 INCLUDING BASE MATERIAL.	SF	5325	\$11.00	\$58,575.00
26	CONSTRUCT CURB RAMP PER CALTRANS STD. PLAN A88A, CASE PER PLAN.	SF	420	\$30.00	\$12,600.00
27	CONSTRUCT LOCAL DEPRESSION PER SPPWC STD. PLAN 313-4, CASE E	EA	1	\$3,082.00	\$3,082.00
28	CONSTRUCT PCC STRUCTURE APPROACH TYPE R (10) PER CALTRANS STD. PLAN B9-2.	EA	3	\$12,864.00	\$38,592.00
29	CONSTRUCT CURB OPENING CATCH BASIN, W=10' AND H=2", PER SPPWC STD PLAN NO. 300-3.	EA	1	\$14,429.00	\$14,429.00
30	CONSTRUCT 18" RCP WITH SAND TRENCH BACKFILL.	LF	13	\$420.00	\$5,460.00
31	CONSTRUCT CONCRETE COLLAR PER SPPWC STD. PLAN 380-4	EA	2	\$1,442.00	\$2,884.00
32	CONSTRUCT MODIFIED MONOLITHIC CATCH BASIN CONNECTION PER SPPWC STD. PLAN 380-2	EA	1	\$3,360.00	\$3,360.00
33	CONSTRUCT 4" PERFORATED PVC SUBDRAIN WITH TRENCH.	LF	320	\$107.00	\$34,240.00
34	CONSTRUCT 6" PVC SUBDRAIN.	LF	465	\$91.00	\$42,315.00
35	CONSTRUCT PCC MOISTURE CUT-OFF BARRIER.	LF	80	\$165.00	\$13,200.00
36	CONSTRUCT 6" PVC SUBDRAIN CLEANOUT.	EA	1	\$600.00	\$600.00
37	UNCLASSIFIED EXCAVATION	CY	770	\$43.00	\$33,110.00
38	2' OVEREXCAVATION	CY	834	\$53.00	\$44,202.00
39	REGRADE SLOPE PER GEOTECHNICAL REPORT. UNCLASSIFIED FILL (IMPORT)	CY	1770	\$97.00	\$171,690.00
40	INSTALL LANDSCAPE PER LANDSCAPE PLANS.	LS	1	\$94,500.00	\$94,500.00
41	INSTALL IRRIGATION PER IRRIGATION PLANS.	LS	1	\$38,850.00	\$38,850.00
42	EXISTING LANDSCAPE AND IRRIGATION TO BE MODIFIED AS REQUIRED TO ACCOMMODATE IMPROVEMENTS.	LS	1	\$16,275.00	\$16,275.00
43	REMOVE AND SALVAGE EXISTING DECORATIVE ROCK AND REINSTALL IN GROUT TO MATCH ADJACENT GRADES.	LS	1	\$5,500.00	\$5,500.00
44	SIGNING AND STRIPING IMPROVEMENTS	LS	1	\$36,540.00	\$36,540.00

Item No	Description	Unit of Measure	Quantity	Sol Construction, Inc - Unit Price	Sol Construction, Inc - Line Total
					\$1,726,114.00
45	REMOVE AND RELOCATE STREETLIGHT POLE AND REPLACE EXISTING 6' MASTARM WITH 8'.	EA	4	\$9,450.00	\$37,800.00
46	REPLACE EXISTING STREETLIGHT 6' MASTARM WITH 8'.	EA	1	\$945.00	\$945.00
	FURNISH AND INSTALL NO.5 PULL BOX JENSEN CAT NO. CYN 20 OR APPROVED EQUAL FOR BOX AND JENSEN CAT NO. CYN16-61J OR APPROVED EQUAL FOR COVER WITH "COI ST LIGHT" MARKED ON THE COVER PER CALTRANS STD PLAN NO. RSP ES-8A.	EA	7	\$1,155.00	\$8,085.00
47					
	FURNISH AND INSTALL NO.6 PULL BOX JENSEN CAT NO. HT1730-B FOR BOX JENSEN CAT NO. HT1730-L11-01 FOR COVER OR APPROVED EQUAL PER CALTRANS STD PLAN NO. RSP ES-8A.	EA	2	\$1,680.00	\$3,360.00
48					
	FURNISH AND INSTALL 160 W LUMINAIRES COOPER LIGHTING MODEL: ARCH-L-PA3-160-740-U-T3-AP-10MSP-10X OR APPROVED EQUAL.	EA	4	\$788.00	\$3,152.00
49					
	REPLACE EXISTING PULLBOX COVER WITH MARKING "COI ST LIGHT".	EA	1	\$473.00	\$473.00
50					
51	FURNISH AND INSTALL 3" PVC SCHEDULE 40 CONDUIT MIN.30" DEEP BETWEEN PULLBOXES.	LF	1200	\$47.00	\$56,400.00
52	FURNISH AND INSTALL 1" PVC SCHEDULE 40 CONDUIT MIN.30" DEEP BETWEEN PULLBOX AND STREET LIGHT FOUNDATION.	LF	50	\$26.00	\$1,300.00
53	FURNISH AND INSTALL 1/0 STRANDED ALUMINUM XHHW WIRE WITHIN 3" PVC CONDUIT PULLBOXES.	LF	3000	\$2.10	\$6,300.00
54	FURNISH AND INSTALL #2 STRANDED ALUMINUM XHHW WIRE WITHIN 3" PVC CONDUIT.	LF	1500	\$2.00	\$3,000.00
55	FURNISH AND INSTALL #6 STRANDED ALUMINUM XHHW WIRES WITHIN 1"PVC CONDUIT TO HANDHOLE ON THE STREETLIGHT POLE.	LF	1500	\$1.50	\$2,250.00
56	FURNISH AND INSTALL FUSES COOPER BUSSMANN KTK-10 WITH FUSE HOLDER OR APPROVED EQUAL AT POLE'S HANDHOLE.	EA	13	\$53.00	\$689.00
57	FURNISH AND INSTALL 4-WAY SECONDARY BARS (3 CONNECTORS PER PB) UTILCO PED4-3505SP WITHIN PULL BOX.	EA	30	\$341.00	\$10,230.00
58	FURNISH AND INSTALL BURNDY INSULATED AL SERVICE ENTRANCE COMPRESSION CONNECTOR CAT NO: ES4W4W ON NEUTRAL WIRE FOR EACH STREETLIGHT POLE.	EA	13	\$16.00	\$208.00
	INSTALL UBICQUIA WIRELESS STREETLIGHT CONTROLLER(NODE) CAT NO. UBC-30-0-01-NA-01-1-GY ON EACH LUMINAIRE (INCLUDE BUNDLE OF 5 YEAR CONNECTIVITY + 5 YEAR UBIVU SERVICES ) AND WORK WITH UBICQUIA TO MAKE REMOTE MONITORING SYSTEM FUNCTIONAL.	EA	4	\$893.00	\$3,572.00
59					
	FURNISH AND INSTALL (2) 40A, 1P,120/240 VOLT CIRCUIT BREAKER ON LOAD SIDE OF EXISTING METERING PEDESTAL.	EA	2	\$32.00	\$64.00
60					
	FURNISH AND INSTALL STREETLIGHT POLE FOUNDATION 2'X2'X4'-6".	EA	4	\$3,150.00	\$12,600.00
61					
					\$150,428.00
					<b>\$1,876,542.00</b>



## CONTRACTORS STATE LICENSE BOARD

### ▼ Contractor's License Detail for License # 812330

**DISCLAIMER: A license status check provides information taken from the CSLB license database. Before relying on this information, you should be aware of the following limitations.**

- ▶ CSLB complaint disclosure is restricted by law (B&P 7124.6) If this entity is subject to public complaint disclosure click on link that will appear below for more information. Click [here](#) for a definition of disclosable actions.
- ▶ Only construction related civil judgments reported to CSLB are disclosed (B&P 7071.17).
- ▶ Arbitrations are not listed unless the contractor fails to comply with the terms.
- ▶ Due to workload, there may be relevant information that has not yet been entered into the board's license database.

Data current as of 4/14/2025 5:18:54 PM

#### Business Information

SOL CONSTRUCTION INC  
231 EAST ALESSANDRO BLVD A445  
RIVERSIDE, CA 92508  
Business Phone Number:(951) 653-1155

**Entity** Corporation  
**Issue Date** 09/10/2002  
**Expire Date** **09/30/2026**

#### License Status

**This license is current and active.**

**All information below should be reviewed.**

#### Classifications

A - GENERAL ENGINEERING

#### Bonding Information

##### Contractor's Bond

This license filed a Contractor's Bond with [EVEREST REINSURANCE COMPANY](#).

**Bond Number:** ES00010504

**Bond Amount:** \$25,000

**Effective Date:** 01/01/2023

[Contractor's Bond History](#)

##### Bond of Qualifying Individual

The qualifying individual MANUEL SALVADOR ANDRADE certified that he/she owns 10 percent or more of the voting stock/membership interest of this company; therefore, the Bond of Qualifying Individual is not required.

**Effective Date:** 11/26/2014

## Workers' Compensation

This license has workers compensation insurance with the [SENTRY INSURANCE COMPANY](#)

**Policy Number:**A0175084002

**Effective Date:** 08/06/2024

**Expire Date:** 08/06/2025

[Workers' Compensation History](#)

**Workers' compensation classification code(s):**

52051 - Concrete/Cement Work-sidewalks-high wage

8810 - Clerical Office Employees

For a description of the workers' compensation classification code(s) listed for this licensee, contact the licensee's insurance carrier. Contact information for the licensee's insurer is available by clicking the insurer link above. Classification codes are also available on the Workers' Compensation Insurance Rating Bureau's classification search page.

**The board does not verify or investigate the accuracy of classification codes displayed.**

### Other

- ▶ Personnel listed on this license (current or disassociated) are listed on other licenses.

[Back to Top](#)

[Privacy Policy](#)

[Accessibility Certification](#)

Copyright © 2025 State of California

[Conditions of Use](#)

[Accessibility](#)



[eCPR Public Search](#)

[Log in](#)

[Public Works Support](#)

[Contractors](#)

[Projects](#)

[Register](#)

[Home](#) > [Customer Account Lookup](#) > SOL CONSTRUCTION, INC.

SOL CONSTRUCTION, INC.

## Customer Account Lookup

Name

SOL CONSTRUCTION, INC.

Customer Account

 SOL CONSTRUCTION, INC.

Type

Contractor

Website

(empty)



Email

mandrade@sol-construction.com

Address 1

231 E. ALESSANDRO BLVDA445

Address\_2

City

RIVERSIDE

State

CA

Zip

92508

Contractor Status

DIR Approved

CSLB

812330

Legal Name

SOL CONSTRUCTION, INC.

Business Structure

-- None --

Business Phone

951.653.1155

Registration Number

President

Manuel Andrade

PWCR

1000012204

Registration Start Date

2025-07-01

Registration End Date

2028-06-30

Doing Business As (DBA)

SOL CONSTRUCTION, INC.

Crafts

Laborer and Related Classifications Operating Engineer Carpenter Cement Mason

Legacy Registration Date

2022-07-01

Legacy Registration Expiration

2025-06-30

## Related Lists

[Historical Registration Dates](#) (1)

[Terms & Conditions](#)

[Privacy Policy](#)

[Disclaimer](#)

[Nondiscrimination Notice](#)

[Accessibility](#)

Copyright 2024 State of California



## NOTICE OF EXEMPTION

**To:** County Clerk  
 County of Los Angeles  
 Environmental Filings  
 12400 East Imperial Highway #2001  
 Norwalk, CA 90650

**From:** City of Industry  
 15625 Mayor Dave Way, Suite 100  
 City of Industry, CA 91744

**Project Title:** CITY-1531 - Grand Avenue Slope Reconstruction and Pavement Rehabilitation from Baker Parkway to Ferrero Parkway

**Project Location - Specific:** The project is located along Grand Avenue from baker Parkway to the ramps leading to Ferrero Parkway.

**Project Location-City:** City of Industry    **Project Location-County:** Los Angeles

**Description of Project:** Reconstruction of the existing roadway slope on the west side of Grand Avenue, north of Baker Parkway and coldmill and overlay of existing AC pavement.

**Name of Public Agency Approving Project:** City of Industry

**Name of Person or Agency Carrying Out Project:** City of Industry

**Exempt Status:** *(check one)*

- Ministerial (Sec. 21080(b)(1); 15268);
- Declared Emergency (Sec. 21080(b)(3); 15269(a));
- Emergency Project (Sec. 21080(b)(4); 15269(b)(c));
- Categorical Exemption. *State type and section number:* 15301 Class 1 (c)
- Statutory Exemptions. *State code number:*

**Reasons why project is exempt:** The proposed project is exempt from the California Environmental Quality Act ("CEQA") per Section 15301(c) of the CEQA Guidelines. Per Section 15301(c) the operation, repair, maintenance, permitting, leasing, licensing, or minor alteration of existing public or private structures, facilities, mechanical equipment, or topographical features, involving negligible or no expansion of use beyond that existing at the time of the lead agency's determination is exempt. The project consists of the reconstruction of the existing roadway slope on the west side of Grand Avenue, north of Baker Parkway and coldmill and overlay of existing AC pavement. The project does not result in an expansion of the use, as the streets are not being expanded to allow for additional traffic, it's simply routine maintenance work.

### Lead Agency

Contact Person: Mathew Hudson

Telephone: (626) 333-2211

Signature: \_\_\_\_\_

Date: April 24, 2025

Title: Director of Public Works

ITEM NO. 6.7

Backup Material will be distributed prior to Meeting

*CITY COUNCIL MEETING*

ITEM NO. 6.7  
HANDOUT



# CITY OF INDUSTRY

## MEMORANDUM

**TO:** Honorable Mayor Moss and Members of the City Council

**FROM:** Joshua Nelson, City Manager

**STAFF:** Mathew Hudson, Director of Public Works  
Sean Calvillo, Sr. Director of Operations, CNC Engineering  
James Cramsie, Sr. Director of Engineering, CNC Engineering

**DATE:** April 24, 2025

**SUBJECT:** Consideration of Amendment No. 9 to the Professional Services Agreement with Stillwater Ecosystem, Watershed & Riverine Sciences, for environmental consulting services at Follows Camp, extending the Term through February 28, 2027, revising the indemnity provisions, revising the scope of services, revising the rate schedule, and increasing compensation by \$757,200.00

---

### **Background:**

On September 23, 2020, the City Manager approved a Professional Services Agreement (“Agreement”) with Stillwater Ecosystem, Watershed & Riverine Sciences (“Stillwater”) to provide environmental consulting services for the Follows Camp bridge replacement project. The initial scope of services included meetings and discussions to address the environmental needs related to Follows Camp including fisheries science, and permitting strategy for the California Department of Fish and Wildlife (“CDFW”), grant funding strategy, and an initial design-related concept development. The Agreement was within the City Manager’s \$10,000.00 signatory authority.

On December 10, 2020, the City Council approved Amendment No. 1, that included additional services to further pursue the grant funding for the proposed bridge replacement through CDFW, and smaller grant fund opportunities. Amendment No. 1 included a companion budget increase of \$61,114.00 for the additional work. The major grant application has been submitted to CDFW. The grant was submitted for \$1,135,560.00 for restoration work including a bridge. The grant was denied and the feedback received from CDFW provided for additional restoration details and clarity on scope and use of the bridge crossing. On June 24, 2021, the City Council approved Amendment No. 2 that included extending the term through December 31, 2021, and additional services for meetings and discussions to address the environmental needs related to Follows Camp including fisheries science, permitting strategy for the CDFW, grant funding strategy, an initial design-related concept development, and cost estimation for the project, with a companion increase in compensation of \$80,000.00.

On April 14, 2022, the City Council approved Amendment No. 3 for additional services that included a grant for the Wildlife Conservation Board (“WCB”) and one with CDFW Fisheries Restoration Grant Program. Additionally, Stillwater also provided the City with new content for updating the City’s website to include new graphics and pictures that highlight Follows Camp and provides educational information about the natural habitat there. Amendment No. 3 also included a revised rate schedule to reflect Stillwater’s current rates, an increase in compensation of \$50,000.00 for additional tasks and project management services, and updated the address for the City.

On October 27, 2022, the City Council approved Amendment No. 4 to extend the term through March 30, 2023, for continued coordination on the WCB grant application and environmental services. On March 23, 2023, the City Council approved Amendment No. 5 to extend the term through September 30, 2023, revise the scope of services, revise the rate schedule, and increase compensation by \$38,000.00. The revised scope of services included further coordination involving the local indigenous communities and regulatory agencies and the WCB preapplication work.

On September 28, 2023, the City Council approved Amendment No. 6 extending the term through March 1, 2024, revising the scope of services, revising the rate schedule, and increasing compensation by \$28,000.00. Stillwater, along with Staff, continued to collaborate with CDFW for its support of the City’s WCB grant pre-application. Upon receiving feedback on the initial pre-application submittal, the subsequent pre-application was accepted by WCB on August 9, 2023, and the City was invited to submit a full grant application. Stillwater prepared the full grant application package that includes the full bridge crossing. There will be ongoing coordination with City Staff, CDFW, local tribal leaders, USDA Forest Service. The additional scope of services also included attending the WCB board meeting in Sacramento in support of the grant. Additionally, Stillwater developed a series of fall cleanup events to take place at Follows Camp to remove trash and implement temporary signage.

On December 14, 2023, the City Council approved Amendment No. 7 revising the scope of services to include preparing and coordinating grant funding through the Rivers and Mountains Conservancy (“RMC”) including pre-project implementation of site signage, litter removal, environmental education and sustainable access design, and submittal of a final application to the RMC after approval of the pre-project submittal. Additionally, the compensation was increased by \$21,000.00 for the additional work.

On February 22, 2024, the City Council approved Amendment No. 8 extending the term through December 31, 2024, to allow Stillwater to continue providing environmental consulting and grant services for Follows Camp. The ongoing work includes collaboration with WCB on the final grant submittal, including an in person presentation to the Board in May. Additionally, the compensation was increased by \$35,000.00 for the term extension.

**Discussion:**

Staff, along with Stillwater Ecosystem, Watershed & Riverine Sciences (“Stillwater”), submitted a full grant application to the Wildlife Conservation Board (“WCB”) for the Follows Camp Ecological Design and Implementation Project (“Project”) on October 13,

2023. The 118-acre Follows Camp project site is located along the East Fork of the San Gabriel River within the San Gabriel Mountains National Monument on City-owned land. Through the grant application, \$2,080,000.00 was requested for the Project.

The Project's main objectives are to:

- 1) restore aquatic, riparian, and upland habitat for special status species and priority habitat types, including critical habitat for the Santa Ana Sucker
- 2) develop and initiate environmental education programs to serve disadvantaged communities from the San Gabriel Valley and support the mission of the San Gabriel Mountains National Monument
- 3) convert commercially and residentially zoned parcels to permanent conservation via a conservation easement.

This will be achieved through the production of a site masterplan, 100 percent design documents for Phase 1 masterplan elements, creation of 5-year stewardship program, and completion of the conservation easement.

The WCB, the Grantor, approved a Grant Agreement at their board meeting on May 23, 2024, and has awarded the City \$2,080,000.00 in grant funds for the Project. The Grant Funds will be used for the purpose of assisting the City with the Project, which is generally described as: planning, studies, and design development to restore aquatic habitat, initiate environmental education programs and promote stewardship and conservation values in the San Gabriel Mountains on the City's 118 acres at Follows Camp. On May 16, 2023, the City Council adopted Resolution No. CC-2024-24, approving the application for grant funds from WCB and authorized the City Manager to execute the Grant Agreement with WCB.

As the Project is set to kick off, the scope of work for Stillwater Sciences comprises part 1 of the overall project which includes the master plan, pre-project implementation, and 35 percent Project designs. The remaining elements of the Project will be developed at the conclusion of part 1 and be provided as part 2, which will include 60-100 percent designs and the Basis of Design Report, permitting, including CEQA, and the conservation easement.

The tasks in part 1 involve coordination with various agencies, site activation and master planning, programmatic restoration planning, environmental education and sustainable access planning, and pre project implementation. Design and permitting will involve restoration design, bridge and low water crossing design, and public access design.

Amendment No. 9 includes extending the term through February 28, 2027, revising the scope of services to include the work outlined in the WCB grant, along with a revised rate schedule to reflect Stillwater's current rates, an increase in compensation of \$757,200.00 for the work. Additionally, it is necessary to revise the indemnity provisions for the indemnity for professional liability section.

**Fiscal Impact:**

Table 1 - Summary of Costs

Contract Amount	\$10,000.00
-----------------	-------------

Amendment No. 1	\$63,114.00
Amendment No. 2	\$80,000.00
Amendment No. 3	\$50,000.00
Amendment No. 5	\$38,000.00
Amendment No. 6	\$28,000.00
Amendment No. 7	\$21,000.00
Amendment No. 8	\$35,000.00
Amendment No. 9	\$757,200.00
<b>Revised Project Cost</b>	<b>\$1,082,314.00</b>

The fiscal impact associated with Amendment No. 9 is \$757,200.00. The City will receive \$2,080,000.00 from WCB in funding for the Project. The City will invoice WCB quarterly for the work completed on the Project that period. The City's required funding match as part of the Grant Agreement is \$1,230,900.00. In the adopted Fiscal Year Capital Improvement Project budget 2024-2025 budget, \$250,000.00 is approved (Account No. 120-726-5130) (MP 11-09 #1) and is sufficient for the initial costs of the Project.

**Recommendation:**

Staff recommends that the City Council approve Amendment No. 9 to the Professional Services Agreement with Stillwater.

**Exhibit:**

- A. Amendment No. 9 to the Professional Services Agreement with Stillwater Ecosystem, Watershed & Riverine Sciences, dated April 24, 2025

---

JN/MH/SC/JC:jf

**EXHIBIT A**

Amendment No. 9 to the Professional Services Agreement with Stillwater Ecosystem,  
Watershed & Riverine Sciences, dated April 24, 2025

[Attached]

**AMENDMENT NO. 9  
TO PROFESSIONAL SERVICES AGREEMENT WITH  
STILLWATER ECOSYSTEM, WATERSHED & RIVERINE SCIENCES**

This Amendment No. 9 to the Professional Services Agreement (“Agreement”) is made and entered into this 24th day of April 2025, (“Effective Date”) by and between the City of Industry, a California municipal corporation (“City”) and Stillwater Ecosystem, Watershed & Riverine Sciences, a California corporation (“Consultant”). The City and Consultant are hereinafter collectively referred to as the “Parties.”

**RECITALS**

**WHEREAS**, on or about September 23, 2020, the Agreement was entered into and executed between the City and Consultant for environmental consulting services for Follows Camp; and

**WHEREAS**, on or about December 10, 2020, Amendment No. 1 to the Agreement was approved for additional work that included partnering and outreach educational elements, conceptual design graphics, and cost estimation for the project, with a companion increase in compensation of \$63,114.00. Additionally, it was necessary to comply with best practices and include indemnity language specific to independent contractors; and

**WHEREAS**, on or about June 24, 2021, Amendment No. 2 to the Agreement was approved for additional work that included meetings and discussions to address the environmental needs related to Follows Camp including fisheries science, permitting strategy, California Department of Fish and Wildlife (“CDFW”) grant funding strategy, and an initial design-related concept development and cost estimation for the project, extending the term through December 31, 2021, along with a companion increase in compensation of \$80,000.00; and

**WHEREAS**, on or about April 14, 2022, Amendment No. 3 was approved, extending the Agreement through September 30, 2022, to allow Consultant to continue providing environmental services, and updating the Agreement to include providing City website content for Follows Camp, and preparation and submission of two additional grant opportunities. It was also necessary to revise the rate schedule to reflect Consultant’s current rates, along with a companion increase in compensation of \$50,000.00, and update the address for the City; and

**WHEREAS**, on or about October 27, 2022, Amendment No. 4 was approved, extending the Agreement through March 30, 2023, to allow Consultant to continue providing environmental services for the Wildlife Conservation Board (“WCB”) grant application; and

**WHEREAS**, on or about March 23, 2023, Amendment No. 5 was approved, extending the Agreement through September 30, 2023, revising the scope of services to provide additional services that include completing the WCB grant preapplication and coordinating further with regulatory agencies, revising the rate schedule to reflect Consultant’s current rates, along with a companion increase in compensation of \$38,000.00; and

**WHEREAS**, on or about September 28, 2023, Amendment No. 6 was approved, extending the Agreement through March 1, 2024, revising the scope of services to provide additional services that include completing the WCB grant preapplication and coordinating further with regulatory agencies, revising the rate schedule to reflect Consultant’s current rates, along with a companion increase in compensation of \$28,000.00; and

**WHEREAS**, on or about December 14, 2023, Amendment No. 7 was approved to revise the scope of services to include a complete grant submittal to the Rivers and Mountains Conservancy for ecosystem/watershed protection, restoration, and public access for the San Gabriel River at Follows Camp along with an increase in compensation of \$21,000.00 for the additional work; and

**WHEREAS**, on or about February 22, 2024, Amendment No. 8 was approved to extend the term through December 31, 2024, to allow Consultant to continue providing grant support services that include completing the full WCB grant application and presentation to WCB, along with an increase in compensation of \$35,000.00; and

**WHEREAS**, the Agreement expired on December 31, 2024, and the Parties desire to extend the term through February 28, 2027, to allow Consultant to provide environmental design services for the WCB grant that was awarded to the City on May 23, 2024, for the Follows Camp Ecological Design and Implementation Project. It is also necessary to revise the scope of services to include those services identified in the grant for environmental design services, revise the rate schedule to reflect Consultant's current rates, along with an increase in compensation of \$757,200.00 for this work. Additionally, the indemnity section is revised for the indemnity for professional liability; and

**WHEREAS**, for the reasons set forth herein, the City and Consultant desire to enter into this Amendment No. 9, as set forth below.

### **AMENDMENT**

**NOW, THEREFORE**, in consideration of the mutual covenants, promises and agreements set forth herein, it is agreed the aforesaid Agreement, a copy of which is attached hereto as Exhibit A, and incorporated herein by reference, shall remain in full force and effect except as otherwise hereinafter provided:

**1. TERM**

Section 1, Term, is hereby revised to read in its entirety as follows:

This Agreement shall commence on the January 1, 2025, and shall remain and continue in effect until tasks described herein are completed, but in no event later than February 27, 2028, unless sooner terminated pursuant to the provisions of this Agreement.

**4. PAYMENT**

The second sentence of Section 4(a) is hereby revised to read in its entirety as follows:

This amount shall not exceed One Million Eighty Two Thousand Three Hundred Fourteen Dollars (\$1,082,314.00) for the total Term of the Agreement unless additional payment is approved as provided in this Agreement.

**7. INDEMNIFICATION**

Section 7(a) is hereby revised to read in its entirety as follows:

When the law establishes a professional standard of care for Consultant's Services, to the fullest extent permitted by law, Consultant shall indemnify, protect, defend and hold harmless

the City and any and all of its officials, employees and agents (“Indemnified Parties”) from and against any and all losses, liabilities, damages, costs and expenses, including legal counsel’s fees and costs to the extent caused in whole or in part by any negligent or wrongful act, error or omission of Consultant, its officers, agents, employees or subconsultants (or any agency or individual that Consultant shall bear the legal liability thereof) in the performance of professional services under this Agreement.

**EXHIBIT A, SCOPE OF SERVICES**

The Scope of Services is hereby revised to include the services set forth in Attachment I, attached hereto and incorporated herein by reference.

**EXHIBIT B, RATE SCHEDULE**

The Rate Schedule is hereby rescinded in its entirety and replaced with rates set forth in Attachment 2, attached hereto and incorporated herein by reference.

The person or persons executing this Agreement on behalf of Consultant represents and warrants that he/she has the authority to execute this Agreement on behalf of the Consultant and has the authority to bind Consultant to the performance of its obligations hereunder.

IN WITNESS WHEREOF, the Parties have executed this Amendment No. 9 to the Agreement as of the Effective Date.

**“CITY”**  
City of Industry

**“CONSULTANT”**  
Stillwater Ecosystem, Watershed &  
Riverine Sciences

By: \_\_\_\_\_  
Joshua Nelson, City Manager

By: \_\_\_\_\_  
Sapna Khandwala, CEO/Principal

**Attest:**

By: \_\_\_\_\_  
Julie Gutierrez-Robles, City Clerk, CMC

**APPROVED AS TO FORM**

By: \_\_\_\_\_  
James M. Casso, City Attorney

**ATTACHMENT 1**  
**EXHIBIT A**  
**SCOPE OF SERVICES**

Consultant shall provide the following additional services:

Consultant shall provide the environmental design services for the Wildlife Conservation Board grant and City-funded Follows Camp Ecological Design and Implementation Project ("Project"). The scope described here comprises Part 1 of the overall Project.

**TASK 1. PROJECT MANAGEMENT**

Consultant will perform a variety of project management duties to ensure that the Project's needs are being met including the following:

- Coordination with the Project Team and agencies
- Coordination of Project meetings

**Deliverables:**

- Quarterly invoices and progress reports

**TASK 2. SITE ACTIVATION & MASTER PLANNING**

This task will result in an overall plan for the 118-acre site, including a long-term vision, phasing, entitlement strategy, and physical site plan combining restoration, educational, environmental stewardship, Japchivit village cultural, and access program elements. To ensure effective integration across the complex ecological, design, and social factors, Consultant will convene a Technical Advisory Committee (TAC) of local experts in wildlife and ecological management, stream flow restoration, National Monument priorities, environmental education, and public access to support the Project. The TAC will provide input into the planning and design process at three key project milestones in Part 1: Visioning; Concept Development and Phase 1 Design Crossing Site Selection; and 35% Designs. In Part 2 and not part of this scope, the TAC will provide input on the 65% Designs.

Consultant will complete a master plan alternatives process leading to a stakeholder-oriented preferred Site Master Plan Document. The focus of the document will be to present the overall project narrative, long-term vision, illustrative graphics, project benefits, and an overall site plan and program for long-term site uses.

**Assumptions:**

- All structural, geotechnical, and transportation-related analysis and design criteria for the bridge, low-water crossing, and vehicular access road intersection(s) with East Fork Road will be completed by others.
- Site study tasks including cultural resource and biological surveys may be deferred to Part 2 pending project needs. Funds for deferred tasks will be held and applied to Part 2 budget.

**Deliverables:**

- Site Master Plan Document
- Photos of signage installed

***Subtask 2a. Programmatic Restoration Planning***

With input from the TAC, Consultant will collaborate with the Project Team to define the long-term, site-wide restoration goals and targets that will be incorporated into the Site Master Plan Document. Restoration planning will address the following as appropriate:

- Consultant will conduct a reconnaissance-level ecological assessment to inform the restoration planning.
- Consultant will include a riparian and aquatic restoration plan in the master plan document that promotes natural fluvial geomorphological processes and natural aquatic habitat complexity through the removal of fill/bank armoring in the floodplain.
- Consultant will develop master plan concepts for the restoration or re-design of existing engineered drainage facilities and culverts outside of the floodplain.
- Consultant will support others in the development of the plan for demolition of abandoned structures, roads, the existing bridge, and the low-water crossing.
- Consultant will develop a plan for the revegetation of formerly cleared and developed areas.
- Consultant will develop a long-term adaptive management, stewardship, and climate resilience strategy.
- Topographic surveys will be completed by others.

***Subtask 2b. Environmental Education and Sustainable Access Planning***

With input from the TAC, Consultant will support the Project Team to define program elements, long-term operations, and preferred public access facilities. Work will be led by other consultants.

**TASK 3. DESIGN & PERMITTING PART 1**

With input from the TAC, Consultant will work with the Project Team to develop 35 percent designs for priority actions for the three primary Project components: 35% Restoration Designs, and 35 percent Environmental Education/Sustainable Public Access Design. The 35 percent river crossing/bridge designs will be developed by others.

Consultant will develop a 35 percent BOD Report focused on the existing conditions assessment, including ecological assessment, 1D hydraulic existing conditions model results, and sufficient information on the conceptual elements to guide the next stage of design for non-bridge or crossing related components.

**Assumptions:**

- Analysis, development, and execution of all design of the bridge and/or crossing will be completed by others. Consultant will not be the engineer of record for these components.

- Consultant will coordinate development of the 35 percent basis of design (“BOD”) and design plan set for the restoration and environmental education/sustainable public access components only. The structural, geotechnical, and transportation design informing the bridge and/or crossing basis of design will be developed by others.
- Engineer's estimate for probable construction cost will be led by others with support from Consultant on habitat restoration design components.

**Deliverables:**

- 35 percent BOD Report including design plans for restoration, crossings (prepared by others), environmental education, and sustainable public access

***Subtask 3a. Restoration Design***

Consultant will develop priority restoration actions identified in the Site Master Planning process to 35 percent design plans and documentation. A Restoration and Adaptive Management and Monitoring Plan will be prepared for ecological restoration of aquatic, floodplain, and upland habitat. The Plan will address implementation, stewardship, monitoring, and adaptive management of the 5- to 10-year post-Project establishment period.

***Subtask 3b. Bridge and Low Water Crossing Design***

The structural, geotechnical, and bridge and low water crossing designs will be developed by others.

***Subtask 3c. Public Access Design***

This subtask includes 35 percent design of a gathering area, environmental education interpretive signage, parking, and associated sustainable access features for the initial phase of site environmental education programs. Consultant will support other consultants in developing 35 percent access designs and supporting graphics, including measures to control unauthorized access to the site, including measures to control unauthorized access to the site.

**TIMELINE AND DELIVERABLES PART 1**

Task	Task	Deliverables	Expected Start Date	Expected Completion Date
1	<b>Project Management</b>	<ul style="list-style-type: none"> <li>• Quarterly invoices and progress reports</li> </ul>	5/1/2025	2/1/2027
2	<b>Site Activation and Master Planning</b>	<ul style="list-style-type: none"> <li>• Site Master Plan Document</li> </ul>	5/1/2025	2/1/2027
2a	Programmatic Restoration Planning			
2b	Environmental Education and Sustainable Access Planning			
2c	Pre-project Implementation			
3	<b>Conceptual Design</b>		11/1/2025	2/1/2027
3a.	Restoration Design	<ul style="list-style-type: none"> <li>• 35% Restoration Design Plans and Specifications</li> <li>• Restoration and Monitoring Plan</li> </ul>		
3c	Environmental Education and Access Program Designs	<ul style="list-style-type: none"> <li>• 35% Env Ed and Access Design Plans</li> </ul>		

**ATTACHMENT 2**

**EXHIBIT B**

**RATE SCHEDULE**

The work is funded in the approved FY 24-25 Capital Improvement Project budget under Account No. 120-726-5130. (MP 11-09 #1)

<b>Billing Classification</b>	<b>Hourly Rate</b>
Scientist/Administrator 1	\$80
Scientist/Administrator 2	\$90
Scientist/Administrator 3	\$101
Scientist/Engineer 4	\$110
Scientist/Engineer 5	\$115
Scientist/Engineer 6	\$125
Scientist/Engineer 7	\$130
Scientist/Engineer 8	\$135
Scientist/Engineer 9	\$140
Scientist/Engineer 10	\$150
Scientist/Engineer 11	\$159
Scientist/Engineer 12	\$168
Scientist/Engineer 13	\$179
Scientist/Engineer 14	\$190
Scientist/Engineer 15	\$200
Scientist/Engineer 16	\$210
Scientist/Engineer 17	\$225
Scientist/Engineer 18	\$244
Scientist/Engineer 19	\$255
Scientist/Engineer 20	\$270

**EXHIBIT A TO AMENDMENT NO. 9**  
**PROFESSIONAL SERVICES AGREEMENT WITH STILLWATER ECOSYSTEM,**  
**WATERSHED & RIVERINE SCIENCES, DATED SEPTEMBER 23, 2020**

## CITY OF INDUSTRY

### PROFESSIONAL SERVICES AGREEMENT

This PROFESSIONAL SERVICES AGREEMENT ("Agreement"), is made and effective as of September 23, 2020 ("Effective Date"), between the City of Industry, a municipal corporation ("City") and Stillwater Ecosystem, Watershed and Riverine Sciences, a California corporation ("Consultant"). The City and Consultant are hereinafter collectively referred to as the "Parties".

#### RECITALS

**WHEREAS**, City desires to engage Consultant to perform the services described herein, and Consultant desires to perform such services in accordance with the terms and conditions set forth herein.

**NOW, THEREFORE**, for and in consideration of the mutual covenants and conditions herein contained, City and Consultant agree as follows:

#### 1. TERM

This Agreement shall commence on the Effective Date, and shall remain and continue in effect until tasks described herein are completed, but in no event later than September 24, 2021, unless sooner terminated pursuant to the provisions of this Agreement.

#### 2. SERVICES

(a) Consultant shall perform the tasks ("Services") described and set forth in Exhibit A, attached hereto and incorporated herein as though set forth in full. ("Scope of Services"). Tasks other than those specifically described in the Scope of Services shall not be performed without prior written approval of the City. The Services shall be performed by Consultant, unless prior written approval is first obtained from the City. In the event of conflict or inconsistency between the terms of this Agreement and Exhibit A, the terms of this Agreement shall prevail.

(b) City shall have the right to request, in writing, changes to the Services. Any such changes mutually agreed upon by the Parties, and any corresponding increase or decrease in compensation, shall be incorporated by written amendment to this Agreement.

(c) Consultant shall perform all Services in a manner reasonably satisfactory to the City and in a first-class manner in conformance with the standards of quality normally observed by an entity providing environmental consulting services, serving a municipal agency.

(d) Consultant shall comply with all applicable federal, state, and local laws, regulations and ordinances in the performance of this Agreement, including but not limited to, the conflict of interest provisions of Government Code Section 1090 and the Political Reform Act (Government Code Section 81000 *et seq.*). During the term of this

Agreement, Consultant shall not perform any work for another person or entity for whom Consultant was not working on the Effective Date if both (i) such work would require Consultant to abstain from a decision under this Agreement pursuant to a conflict of interest statute or law; and (ii) City has not consented in writing to Consultant's performance of such work. No officer or employee of City shall have any financial interest in this Agreement that would violate California Government Code Sections 1090 *et seq.* Consultant hereby warrants that it is not now, nor has it been in the previous twelve (12) months, an employee, agent, appointee, or official of the City. If Consultant was an employee, agent, appointee, or official of the City in the previous twelve (12) months, Consultant warrants that it did not participate in any manner in the forming of this Agreement. Consultant understands that, if this Agreement is made in violation of Government Code §1090 *et. seq.*, the entire Agreement is void and Consultant will not be entitled to any compensation for Services performed pursuant to this Agreement, and Consultant will be required to reimburse the City for any sums paid to the Consultant. Consultant understands that, in addition to the foregoing, it may be subject to criminal prosecution for a violation of Government Code § 1090 and, if applicable, will be disqualified from holding public office in the State of California.

(e) Consultant represents that it has, or will secure at its own expense, all licensed personnel required to perform the Services. All Services shall be performed by Consultant or under its supervision, and all personnel engaged in the Services shall be qualified and licensed to perform such services.

### **3. MANAGEMENT**

City Manager shall represent the City in all matters pertaining to the administration of this Agreement, review and approval of all products submitted by Consultant, but shall have no authority to modify the Services or the compensation due to Consultant.

### **4. PAYMENT**

(a) The City agrees to pay Consultant monthly, in accordance with the payment rates and terms and the schedule of payment as set forth in Exhibit B ("Rate Schedule"), attached hereto and incorporated herein by this reference as though set forth in full, based upon actual time spent on the above tasks. This amount shall not exceed Ten Thousand Dollars (\$10,000.00) for the total Term of the Agreement unless additional payment is approved as provided in this Agreement.

(b) Consultant shall not be compensated for any services rendered in connection with its performance of this Agreement which are in addition to those set forth herein, unless such additional services are authorized in advance and in writing by the City. Consultant shall be compensated for any additional services in the amounts and in the manner as agreed to by City and Consultant at the time City's written authorization is given to Consultant for the performance of said services.

(c) Consultant shall submit invoices monthly for actual services performed. Invoices shall be submitted on or about the first business day of each month, or as soon thereafter as practical, for services provided in the previous month. Payment shall be made within thirty

(30) days of receipt of each invoice as to all non-disputed fees. If the City disputes any of Consultant's fees it shall give written notice to Consultant within thirty (30) days of receipt of an invoice of any disputed fees set forth on the invoice. Any final payment under this Agreement shall be made within 45 days of receipt of an invoice therefore.

## **5. SUSPENSION OR TERMINATION OF AGREEMENT**

(a) The City may at any time, for any reason, with or without cause, suspend or terminate this Agreement, or any portion hereof, by serving upon the Consultant at least ten (10) days prior written notice. Upon receipt of said notice, the Consultant shall immediately cease all work under this Agreement, unless the notice provides otherwise. If the City suspends or terminates a portion of this Agreement such suspension or termination shall not make void or invalidate the remainder of this Agreement.

(b) In the event this Agreement is terminated pursuant to this Section, the City shall pay to Consultant the actual value of the work performed up to the time of termination, provided that the work performed is of value to the City. Upon termination of the Agreement pursuant to this Section, the Consultant shall submit an invoice to the City pursuant to Section 5 of this Agreement.

## **6. OWNERSHIP OF DOCUMENTS**

(a) Consultant shall maintain complete and accurate records with respect to sales, costs, expenses, receipts, and other such information required by City that relate to the performance of services under this Agreement. Consultant shall maintain adequate records of services provided in sufficient detail to permit an evaluation of services. All such records shall be maintained in accordance with generally accepted accounting principles and shall be clearly identified and readily accessible. Consultant shall provide free access to the representatives of City or its designees at reasonable times to review such books and records; shall give City the right to examine and audit said books and records; shall permit City to make transcripts or copies therefrom as necessary; and shall allow inspection of all work, data, documents, proceedings, and activities related to this Agreement. Such records, together with supporting documents, shall be maintained for a period of three (3) years after receipt of final payment.

(b) Upon completion of, or in the event of termination or suspension of this Agreement, all original documents, designs, drawings, maps, models, computer files, surveys, notes, and other documents prepared in the course of providing the services to be performed pursuant to this Agreement shall become the sole property of the City and may be used, reused, or otherwise disposed of by the City without the permission of the Consultant, so long as the Consultant is not held responsible. With respect to computer files, Consultant shall make available to the City, at the Consultant's office, and upon reasonable written request by the City, the necessary computer software and hardware for purposes of accessing, compiling, transferring, copying and/or printing computer files. Consultant hereby grants to City all right, title, and interest, including any copyright, in and to the documents, designs, drawings, maps, models, computer files, surveys, notes, and other documents prepared by Consultant in the course of providing the services under this Agreement. All reports, documents, or other

written material developed by Consultant in the performance of the Services pursuant to this Agreement, shall be and remain the property of the City.

## **7. INDEMNIFICATION**

### **(a) Indemnity for professional liability**

When the law establishes a professional standard of care for Consultant's Services, to the fullest extent permitted by law, Consultant shall indemnify, protect and hold harmless the City and any and all of its officials, employees and agents ("Indemnified Parties") from and against any and all losses, liabilities, damages, costs and expenses, including legal counsel's fees and costs to the extent caused by any negligent or wrongful act, error or omission of Consultant, its officers, agents, employees or Subconsultants (or any agency or individual that Consultant shall bear the legal liability thereof) in the performance of professional services under this Agreement.

### **(b) Indemnity for other than professional liability**

Other than in the performance of professional services and to the full extent permitted by law, Consultant shall indemnify, defend and hold harmless City, and any and all of its employees, officials and agents from and against any liability (including liability for claims, suits, actions, arbitration proceedings, administrative proceedings, regulatory proceedings, losses, expenses or costs of any kind, whether actual, alleged or threatened, including legal counsel fees and costs, court costs, interest, defense costs, and expert witness fees), where the same arise out of, are a consequence of, or are in any way attributable to, in whole or in part, the performance of this Agreement by Consultant or by any individual or agency for which Consultant is legally liable, including but not limited to officers, agents, employees or subcontractors of Consultant.

## **8. INSURANCE**

Consultant shall maintain prior to the beginning of and for the duration of this Agreement insurance coverage as specified in Exhibit C attached hereto and incorporated herein by reference.

## **9. INDEPENDENT CONSULTANT**

(a) Consultant is and shall at all times remain as to the City a wholly independent consultant and/or independent contractor. The personnel performing the services under this Agreement on behalf of Consultant shall at all times be under Consultants exclusive direction and control. Neither City nor any of its officers, employees, or agents shall have control over the conduct of Consultant or any of Consultant's officers, employees, or agents, except as set forth in this Agreement. Consultant shall not at any time or in any manner represent that it or any of its officers, employees, or agents are in any manner officers, employees, or agents of the City. Consultant shall not incur or have the power to incur any debt, obligation, or liability whatever against the City, or bind the City in any manner.

(b) No employee benefits shall be available to Consultant in connection with the performance of this Agreement. Except for the fees paid to Consultant as provided in the Agreement, City shall not pay salaries, wages, or other compensation to Consultant for performing services hereunder for City. City shall not be liable for compensation or indemnification to Consultant for injury or sickness arising out of performing services hereunder.

**10. LEGAL RESPONSIBILITIES**

The Consultant shall keep itself informed of State and Federal laws and regulations which in any manner affect those employed by it or in any way affect the performance of its service pursuant to this Agreement. The Consultant shall at all times observe and comply with all such laws and regulations. The City, and its officers and employees, shall not be liable at law or in equity occasioned by failure of the Consultant to comply with this Section.

**11. UNDUE INFLUENCE**

Consultant declares and warrants that no undue influence or pressure was used against or in concert with any officer or employee of the City in connection with the award, terms or implementation of this Agreement, including any method of coercion, confidential financial arrangement, or financial inducement. No officer or employee of the City has or will receive compensation, directly or indirectly, from Consultant, or from any officer, employee or agent of Consultant, in connection with the award of this Agreement or any work to be conducted as a result of this Agreement. Violation of this Section shall be a material breach of this Agreement entitling the City to any and all remedies at law or in equity.

**12. NO BENEFIT TO ARISE TO LOCAL OFFICERS AND EMPLOYEES**

No member, officer, or employee of City, or their designees or agents, and no public official who exercises authority over or responsibilities with respect to the Project during his/her tenure or for one year thereafter, shall have any interest, direct or indirect, in any agreement or sub-agreement, or the proceeds thereof, for work to be performed in connection with the Project performed under this Agreement.

**13. RELEASE OF INFORMATION/CONFLICTS OF INTEREST**

(a) All information gained by Consultant in performance of this Agreement shall be considered confidential and shall not be released by Consultant without City's prior written authorization. Consultant, its officers, employees, agents, or subconsultants, shall not without written authorization from the City, voluntarily provide declarations, letters of support, testimony at depositions, response to interrogatories, or other information concerning the work performed under this Agreement or relating to any project or property located within the City, unless otherwise required by law or court order.

(b) Consultant shall promptly notify City should Consultant, its officers, employees, agents, or subconsultants be served with any summons, complaint, subpoena, notice of deposition, request for documents, interrogatories, request for admissions, or other discovery request ("Discovery"), court order, or subpoena from any person or party regarding this

Agreement and the work performed there under or with respect to any project or property located within the City, unless Consultant is prohibited by law from informing the City of such Discovery, court order or subpoena. City retains the right, but has no obligation, to represent Consultant and/or be present at any deposition, hearing, or similar proceeding as allowed by law. Unless City is a party to the lawsuit, arbitration, or administrative proceeding and is adverse to Consultant in such proceeding, Consultant agrees to cooperate fully with the City and to provide the opportunity to review any response to discovery requests provided by Consultant. However, City's right to review any such response does not imply or mean the right by City to control, direct, or rewrite said response.

**14. NOTICES**

Any notices which either party may desire to give to the other party under this Agreement must be in writing and may be given either by (i) personal service, (ii) delivery by a reputable document delivery service, such as but not limited to, Federal Express, which provides a receipt showing date and time of delivery, or (iii) mailing in the United States Mail, certified mail, postage prepaid, return receipt requested, addressed to the address of the party as set forth below or at any other address as that party may later designate by notice:

To City:	City of Industry 15625 E. Stafford, Suite 100 City of Industry, CA 91744 Attention: City Manager
With a Copy To:	Casso & Sparks, LLP 13300 Crossroads Parkway North, Suite 410 City of Industry, CA 91746 Attention: James M. Casso, City Attorney
To Consultant:	Stillwater Ecosystem, Watershed and Riverine Sciences 555 W. 5 <sup>th</sup> Street, 35 <sup>th</sup> Floor Los Angeles, CA 90013 Attention: Wendy Katagi, Senior Manager

**15. ASSIGNMENT**

The Consultant shall not assign the performance of this Agreement, nor any part thereof, nor any monies due hereunder, without prior written consent of the City.

Before retaining or contracting with any subconsultant for any services under this Agreement, Consultant shall provide City with the identity of the proposed subconsultant, a copy of the proposed written contract between Consultant and such subconsultant which shall include and indemnity provision similar to the one provided herein and identifying City as an indemnified party, or an incorporation of the indemnity provision provided herein, and proof that such proposed subconsultant carries insurance at least equal to that required by this Agreement or obtain a written waiver from the City for such insurance.

Notwithstanding Consultant's use of any subconsultant, Consultant shall be responsible to the City for the performance of its subconsultant as it would be if Consultant had performed the Services itself. Nothing in this Agreement shall be deemed or construed to create a contractual relationship between the City and any subconsultant employed by Consultant. Consultant shall be solely responsible for payments to any subconsultants. Consultant shall indemnify, defend and hold harmless the Indemnified Parties for any claims arising from, or related to, the services performed by a subconsultant under this Agreement.

**16. GOVERNING LAW/ATTORNEYS' FEES**

The City and Consultant understand and agree that the laws of the State of California shall govern the rights, obligations, duties, and liabilities of the parties to this Agreement and also govern the interpretation of this Agreement. Any litigation concerning this Agreement shall take place in the municipal, superior, or federal district court in Los Angeles County, California. If any action at law or suit in equity is brought to enforce or interpret the provisions of this Agreement, or arising out of or relating to the Services provided by Consultant under this Agreement, the prevailing party shall be entitled to reasonable attorneys' fees and all related costs, including costs of expert witnesses and consultants, as well as costs on appeal, in addition to any other relief to which it may be entitled.

**17. ENTIRE AGREEMENT**

This Agreement contains the entire understanding between the Parties relating to the obligations of the Parties described in this Agreement. All prior or contemporaneous agreements, understandings, representations, and statements, oral or written and pertaining to the subject of this Agreement or with respect to the terms and conditions of this Agreement, are merged into this Agreement and shall be of no further force or effect. Each party is entering into this Agreement based solely upon the representations set forth herein and upon each party's own independent investigation of any and all facts such party deems material.

**18. SEVERABILITY**

If any term or provision of this Agreement or the application thereof to any person or circumstance shall, to any extent, be invalid or unenforceable, then such term or provision shall be amended to, and solely to, the extent necessary to cure such invalidity or unenforceability, and in its amended form shall be enforceable. In such event, the remainder of this Agreement, or the application of such term or provision to persons or circumstances other than those as to which it is held invalid or unenforceable, shall not be affected thereby, and each term and provision of this Agreement shall be valid and be enforced to the fullest extent permitted by law.

**19. COUNTERPARTS**

This Agreement may be executed in multiple counterparts, each of which shall be deemed an original, but all of which taken together shall constitute one and the same instrument.

**20. CAPTIONS**

The captions appearing at the commencement of the sections hereof, and in any paragraph thereof, are descriptive only and shall have no significance in the interpretation of this Agreement.

**21. WAIVER**

The waiver by City or Consultant of any breach of any term, covenant or condition herein contained shall not be deemed to be a waiver of such term, covenant or condition or of any subsequent breach of the same or any other term, covenant or condition herein contained. No term, covenant or condition of this Agreement shall be deemed to have been waived by City or Consultant unless in writing.

**22. REMEDIES**

Each right, power and remedy provided for herein or now or hereafter existing at law, in equity, by statute, or otherwise shall be cumulative and shall be in addition to every other right, power, or remedy provided for herein or now or hereafter existing at law, in equity, by statute, or otherwise. The exercise, the commencement of the exercise, or the forbearance of the exercise by any party of any one or more of such rights, powers or remedies shall not preclude the simultaneous or later exercise by such party of any of all of such other rights, powers or remedies.

**23. AUTHORITY TO EXECUTE THIS AGREEMENT**

The person or persons executing this Agreement on behalf of Consultant represents and warrants that he/she has the authority to execute this Agreement on behalf of the Consultant and has the authority to bind Consultant to the performance of its obligations hereunder.

IN WITNESS WHEREOF, the Parties hereto have caused this Agreement to be executed as of the Effective Date.

**"CITY"**  
City of Industry

**"CONSULTANT"**  
Stillwater Ecosystem, Watershed and  
Riverine Sciences

By:   
Troy Helling, City Manager

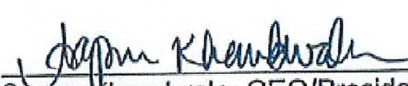
By:   
Sapna Khandwala, CEO/President

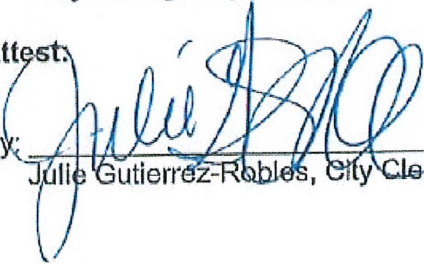
Attest:  
By:   
Julie Gutierrez-Robles, City Clerk

Approved as to form:

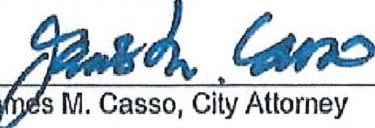
By:   
James M. Casso, City Attorney

Attachments:	Exhibit A	Scope of Services
	Exhibit B	Rate Schedule
	Exhibit C	Insurance Requirements

EXHIBIT A

SCOPE OF SERVICES

Consultant shall provide the following services for work at Follows Camp:

Conduct up to three (3) meetings, including producing meeting summaries for each meeting, to address study questions and environmental needs related to Follows Camp with the following topics/services:

1. Fisheries science
2. Permitting strategy (California Department of Fish and Wildlife)
3. Grant funding strategy
4. Initial design-related concept development

EXHIBIT B  
RATE SCHEDULE

Classification	Hourly Rate
Scientist Administrator 1	\$65
Scientist Administrator 2	\$76
Scientist Administrator 3	\$84
Scientist Engineer 4	\$93
Scientist Engineer 5	\$99
Scientist Engineer 6	\$107
Scientist Engineer 7	\$113
Scientist Engineer 8	\$117
Scientist Engineer 9	\$126
Scientist Engineer 10	\$133
Scientist Engineer 11	\$144
Scientist Engineer 12	\$151
Scientist Engineer 13	\$161
Scientist Engineer 14	\$170
Scientist Engineer 15	\$182
Scientist Engineer 16	\$196
Scientist Engineer 17	\$219
Scientist Engineer 18	\$230
Scientist Engineer 19	\$245
Scientist Engineer 20	\$260

Rates listed above are for calendar year 2020. Hourly rates will be adjusted on January 1<sup>st</sup> of each year.

## EXHIBIT C

### INSURANCE REQUIREMENTS

Without limiting Consultant's indemnification of City, and prior to commencement of the Services, Consultant shall obtain, provide and maintain at its own expense during the term of this Agreement, policies of insurance of the type and amounts described below and in a form satisfactory to City.

**General liability insurance.** Consultant shall maintain commercial general liability insurance with coverage at least as broad as Insurance Services Office form CG 00 01, in an amount not less than \$1,000,000.00 per occurrence, \$2,000,000.00 general aggregate, for bodily injury, personal injury, and property damage. The policy must include contractual liability that has not been amended. Any endorsement restricting standard ISO "insured contract" language will not be accepted.

**Automobile liability insurance.** Consultant shall maintain automobile insurance at least as broad as Insurance Services Office form CA 00 01 covering bodily injury and property damage for all activities of the Consultant arising out of or in connection with Work to be performed under this Agreement, including coverage for any owned, hired, non-owned or rented vehicles, in an amount not less than \$1,000,000.00 combined single limit for each accident.

**Professional liability (errors & omissions) insurance.** Consultant shall maintain professional liability insurance that covers the Services to be performed in connection with this Agreement, in the minimum amount of \$1,000,000 per claim and in the aggregate. Any policy inception date, continuity date, or retroactive date must be before the effective date of this agreement and Consultant agrees to maintain continuous coverage through a period no less than three years after completion of the services required by this agreement.

**Workers' compensation insurance.** Consultant shall maintain Workers' Compensation Insurance (Statutory Limits) and Employer's Liability Insurance (with limits of at least \$1,000,000.00).

Consultant shall submit to City, along with the certificate of insurance, a Waiver of Subrogation endorsement in favor of City, its officers, agents, employees and volunteers.

**Proof of insurance.** Consultant shall provide certificates of insurance to City as evidence of the insurance coverage required herein, along with a waiver of subrogation endorsement for workers' compensation. Insurance certificates and endorsement must be approved by City's Risk Manager prior to commencement of performance. Current certification of insurance shall be kept on file with City at all times during the term of this contract. City reserves the right to require complete, certified copies of all required insurance policies, at any time.

**Duration of coverage.** Consultant shall procure and maintain for the duration of the contract insurance against claims for injuries to persons or damages to property, which may arise from or in connection with the performance of the Services hereunder by Consultant, his agents, representatives, employees or subconsultants.

**Primary/noncontributing.** Coverage provided by Consultant shall be primary and any insurance or self-insurance procured or maintained by City shall not be required to contribute with it. The limits of insurance required herein may be satisfied by a combination of primary and umbrella or excess insurance. Any umbrella or excess insurance shall contain or be endorsed to contain a provision that such coverage shall also apply on a primary and non-contributory basis for the benefit of City before the City's own insurance or self-insurance shall be called upon to protect it as a named insured.

**City's rights of enforcement.** In the event any policy of insurance required under this Agreement does not comply with these specifications or is canceled and not replaced, City has the right but not the duty to obtain the insurance it deems necessary and any premium paid by City will be promptly reimbursed by Consultant, or City will withhold amounts sufficient to pay premium from Consultant payments. In the alternative, City may cancel this Agreement.

**Acceptable insurers.** All insurance policies shall be issued by an insurance company currently authorized by the Insurance Commissioner to transact business of insurance in the State of California, with an assigned policyholders' Rating of A- (or higher) and Financial Size Category Class VI (or larger) in accordance with the latest edition of Best's Key Rating Guide, unless otherwise approved by the City's Risk Manager.

**Waiver of subrogation.** All insurance coverage maintained or procured pursuant to this agreement shall be endorsed to waive subrogation against City, its elected or appointed officers, agents, officials, employees and volunteers or shall specifically allow Consultant or others providing insurance evidence in compliance with these specifications to waive their right of recovery prior to a loss. Consultant hereby waives its own right of recovery against City, and shall require similar written express waivers and insurance clauses from each of its subconsultants.

**Enforcement of contract provisions (non estoppel).** Consultant acknowledges and agrees that any actual or alleged failure on the part of the City to inform Consultant of non-compliance with any requirement imposes no additional obligations on the City nor does it waive any rights hereunder.

**Requirements not limiting.** Requirements of specific coverage features or limits contained in this Section are not intended as a limitation on coverage, limits or other requirements, or a waiver of any coverage normally provided by any insurance. Specific reference to a given coverage feature is for purposes of clarification only as it pertains to a given issue and is not intended by any party or insured to be all inclusive, or to the exclusion of other coverage, or a waiver of any type. If the Consultant maintains higher limits than the minimums shown above, the City requires and shall be entitled to coverage for the higher limits maintained by the Consultant. Any available insurance proceeds in excess of the specified minimum limits of insurance and coverage shall be available to the City.

**Notice of cancellation.** Consultant agrees to oblige its insurance agent or broker and insurers to provide to City with a thirty (30) day notice of cancellation (except for nonpayment for which a ten (10) day notice is required) or nonrenewal of coverage for each required coverage.

**Additional insured status.** General liability policies shall provide or be endorsed to provide that City and its officers, officials, employees, and agents, and volunteers shall be additional insureds under such policies. This provision shall also apply to any excess liability policies.

**Prohibition of undisclosed coverage limitations.** None of the coverages required herein will be in compliance with these requirements if they include any limiting endorsement of any kind that has not been first submitted to City and approved of in writing.

**Separation of insureds.** A severability of interests provision must apply for all additional insureds ensuring that Consultant's insurance shall apply separately to each insured against whom claim is made or suit is brought, except with respect to the insurer's limits of liability. The policy(ies) shall not contain any cross-liability exclusions.

**Pass Through Clause.** Consultant agrees to ensure that its subconsultants, subcontractors, and any other party involved with the project who is brought onto or involved in the project by Consultant, provide the same minimum insurance coverage and endorsements required of Consultant. Consultant agrees to monitor and review all such coverage and assumes all responsibility for ensuring that such coverage is provided in conformity with the requirements of this section. Consultant agrees that upon request, all agreements with consultants, subcontractors, and others engaged in the project will be submitted to City for review.

**City's right to revise specifications.** The City reserves the right at any time during the term of the contract to change the amounts and types of insurance required by giving the Consultant ninety (90) days advance written notice of such change. If such change results in substantial additional cost to the Consultant, the City and Consultant may renegotiate Consultant's compensation.

**Self-insured retentions.** Any self-insured retentions must be declared to and approved by the City. The City reserves the right to require that self-insured retentions be eliminated, lowered, or replaced by a deductible. Self-insurance will not be considered to comply with these specifications unless approved by the City.

**Timely notice of claims.** Consultant shall give the City prompt and timely notice of claims made or suits instituted that arise out of or result from Consultant's performance under this Agreement, and that involve or may involve coverage under any of the required liability policies.

**Additional insurance.** Consultant shall also procure and maintain, at its own cost and expense, any additional kinds of insurance, which in its own judgment may be necessary for its proper protection and prosecution of the work.

ITEM NO. 6.8

Backup Material will be distributed prior to Meeting

*CITY COUNCIL MEETING*

ITEM NO. 6.8  
HANDOUT



# CITY OF INDUSTRY

## MEMORANDUM

**TO:** Honorable Mayor Moss and Members of the City Council

**FROM:** Joshua Nelson, City Manager

**STAFF:** Mathew Hudson, Director of Public Works  
Sean Calvillo, Sr. Director of Operations, CNC Engineering

**DATE:** April 24, 2025

**SUBJECT:** Consideration of a Professional Services Agreement with Mark Thomas & Company, Inc., to provide structural engineering design services, for the Follows Camp Ecological Design and Implementation Project, in an amount of \$363,900.00, through February 28, 2028

---

### **Background:**

Staff, along with Stillwater Ecosystem, Watershed & Riverine Sciences (“Stillwater”), submitted a full grant application to the Wildlife Conservation Board (“WCB”) for the Follows Camp Ecological Design and Implementation Project (“Project”) on October 13, 2023. The 118-acre Follows Camp project site is located along the East Fork of the San Gabriel River within the San Gabriel Mountains National Monument on City-owned land. Through the grant application, \$2,080,000.00 was requested for the Project.

The Project’s main objectives are to:

- 1) restore aquatic, riparian, and upland habitat for special status species and priority habitat types, including critical habitat for the Santa Ana Sucker
- 2) develop and initiate environmental education programs to serve disadvantaged communities from the San Gabriel Valley and support the mission of the San Gabriel Mountains National Monument
- 3) convert commercially and residentially zoned parcels to permanent conservation via a conservation easement.

This will be achieved through the production of a site masterplan, 100 percent design documents for Phase 1 masterplan elements, creation of 5-year stewardship program, and completion of the conservation easement.

The WCB, the Grantor, approved a Grant Agreement at their board meeting on May 23, 2024, and has awarded the City \$2,080,000.00 in grant funds for the Project. The Grant Funds will be used for the purpose of assisting the City with the Project, which is generally described as: planning, studies, and design development to restore aquatic habitat,

initiate environmental education programs and promote stewardship and conservation values in the San Gabriel Mountains on the City's 118 acres at Follows Camp. On May 16, 2023, the City Council adopted Resolution No. CC-2024-24, approving the application for grant funds from WCB and authorized the City Manager to execute the Grant Agreement with WCB.

**Discussion:**

As the Project is set to kick off, the scope of work for Mark Thomas & Company ("Mark Thomas") comprises part 1 of the overall project which includes the master plan, pre-project implementation, and 35 percent Project designs related to structural engineering and geotechnical engineering. The remaining elements of the Project will be developed at the conclusion of part 1 and be provided as part 2, which will include 60-100 percent designs and the Basis of Design Report, permitting, including CEQA, and the conservation easement.

The tasks in part 1 involve developing conceptual design alternatives and feasibility analysis, including locations for the bridge crossing, approaches and low water crossing options. Subsequently, Mark Thomas will prepare 35 percent design plans for the bridge and low water crossing, geotechnical and foundational designs, and preliminary cost estimates for construction.

This was previously approved at the November 14, 2024 City Council meeting. However, after the meeting, Mark Thomas presented comments and changes to the Professional Services Agreement ("Agreement"). Staff have worked with the City Attorney and Mark Thomas, and the Agreement has been modified. The indemnity section of the Agreement has been revised with language relating specifically to engineering design firms. Staff recommends approving the Agreement with Mark Thomas in the amount of \$363,900.00 through February 28, 2027.

**Fiscal Impact:**

The fiscal impact is \$363,900.00 for part 1. The City will receive \$2,080,000.00 from WCB in funding for the Project. The City will invoice WCB quarterly for the work completed on the Project that period. The City's required funding match as part of the Grant Agreement is \$1,230,900.00. In the adopted Fiscal Year Capital Improvement Project budget 2024-2025 budget, \$250,000.00 is approved (Account No. 120-726-5130) (MP 11-09 #1) and is sufficient for the initial costs of the Project.

**Recommendation:**

Approve the Professional Services Agreement with Mark Thomas.

**Exhibit:**

- A. Professional Services Agreement with Mark Thomas & Company, Inc., dated April 24, 2025

**EXHIBIT A:**

Professional Services Agreement with Mark Thomas & Company, Inc., dated  
April 24, 2025

[Attached]

## CITY OF INDUSTRY

### PROFESSIONAL SERVICES AGREEMENT

This PROFESSIONAL SERVICES AGREEMENT (“Agreement”), is made and effective as of April 24, 2025 (“Effective Date”), between the City of Industry, a municipal corporation (“City”) and Mark Thomas & Company, Inc., a California corporation (“Consultant”). The City and Consultant are hereinafter collectively referred to as the “Parties”.

#### RECITALS

**WHEREAS**, City desires to engage Consultant to perform the services described herein, and Consultant desires to perform such services in accordance with the terms and conditions set forth herein.

**NOW, THEREFORE**, for and in consideration of the mutual covenants and conditions herein contained, City and Consultant agree as follows:

#### 1. TERM

This Agreement shall commence on the Effective Date, and shall remain and continue in effect until tasks described herein are completed, but in no event later than February 28, 2027, unless sooner terminated pursuant to the provisions of this Agreement.

#### 2. SERVICES

(a) Consultant shall perform the tasks (“Services”) described and set forth in Exhibit A, attached hereto and incorporated herein as though set forth in full. (“Scope of Services”). Tasks other than those specifically described in the Scope of Services shall not be performed without prior written approval of the City. The Services shall be performed by Consultant, unless prior written approval is first obtained from the City. In the event of conflict or inconsistency between the terms of this Agreement and Exhibit A, the terms of this Agreement shall prevail.

(b) City shall have the right to request, in writing, changes to the Services. Any such changes mutually agreed upon by the Parties, and any corresponding increase or decrease in compensation, shall be incorporated by written amendment to this Agreement.

(c) Consultant shall perform all Services in a manner reasonably satisfactory to the City and in a first-class manner in conformance with the standards of quality normally observed by an entity providing structural engineering design services, serving a municipal agency.

(d) Consultant shall comply with all applicable federal, state, and local laws, regulations and ordinances in the performance of this Agreement, including but not limited to, the conflict of interest provisions of Government Code Section 1090 and the Political Reform Act (Government Code Section 81000 *et seq.*). During the term of this Agreement,

Consultant shall not perform any work for another person or entity for whom Consultant was not working on the Effective Date if both (i) such work would require Consultant to abstain from a decision under this Agreement pursuant to a conflict of interest statute or law; and (ii) City has not consented in writing to Consultant's performance of such work. No officer or employee of City shall have any financial interest in this Agreement that would violate California Government Code Sections 1090 *et seq.* Consultant hereby warrants that it is not now, nor has it been in the previous twelve (12) months, an employee, agent, appointee, or official of the City. If Consultant was an employee, agent, appointee, or official of the City in the previous twelve (12) months, Consultant warrants that it did not participate in any manner in the forming of this Agreement. Consultant understands that, if this Agreement is made in violation of Government Code §1090 *et seq.*, the entire Agreement is void and Consultant will not be entitled to any compensation for Services performed pursuant to this Agreement, and Consultant will be required to reimburse the City for any sums paid to the Consultant. Consultant understands that, in addition to the foregoing, it may be subject to criminal prosecution for a violation of Government Code § 1090 and, if applicable, will be disqualified from holding public office in the State of California.

(e) Consultant represents that it has, or will secure at its own expense, all licensed personnel required to perform the Services. All Services shall be performed by Consultant or under its supervision, and all personnel engaged in the Services shall be qualified and licensed to perform such services.

### **3. MANAGEMENT**

City Manager shall represent the City in all matters pertaining to the administration of this Agreement, review and approval of all products submitted by Consultant, but shall have no authority to modify the Services or the compensation due to Consultant.

### **4. PAYMENT**

(a) The City agrees to pay Consultant monthly, in accordance with the payment rates and terms and the schedule of payment as set forth in Exhibit B ("Rate Schedule"), attached hereto and incorporated herein by this reference as though set forth in full, based upon actual time spent on the above tasks. This amount shall not exceed Three Hundred Sixty Three Thousand Nine Hundred Dollars (\$363,900.00) for the total Term of the Agreement unless additional payment is approved as provided in this Agreement.

(b) Consultant shall not be compensated for any services rendered in connection with its performance of this Agreement which are in addition to those set forth herein, unless such additional services are authorized in advance and in writing by the City. Consultant shall be compensated for any additional services in the amounts and in the manner as agreed to by City and Consultant at the time City's written authorization is given to Consultant for the performance of said services.

(c) Consultant shall submit invoices monthly for actual services performed. Invoices shall be submitted on or about the first business day of each month, or as soon thereafter as practical, for services provided in the previous month. Payment shall be made within thirty (30) days of

receipt of each invoice as to all non-disputed fees. If the City disputes any of Consultant's fees it shall give written notice to Consultant within thirty (30) days of receipt of an invoice of any disputed fees set forth on the invoice. Any final payment under this Agreement shall be made within 45 days of receipt of an invoice therefore.

## **5. SUSPENSION OR TERMINATION OF AGREEMENT**

(a) The City may at any time, for any reason, with or without cause, suspend or terminate this Agreement, or any portion hereof, upon reasonable written notice to Consultant. Upon receipt of said notice, the Consultant shall immediately cease all work under this Agreement, unless the notice provides otherwise. If the City suspends or terminates a portion of this Agreement such suspension or termination shall not make void or invalidate the remainder of this Agreement.

(b) In the event this Agreement is terminated pursuant to this Section, the City shall pay to Consultant the actual value of the work performed up to the time of termination, provided that the work performed is of value to the City. Upon termination of the Agreement pursuant to this Section, the Consultant shall submit an invoice to the City pursuant to Section 5 of this Agreement.

## **6. OWNERSHIP OF DOCUMENTS**

(a) Consultant shall maintain complete and accurate records with respect to sales, costs, expenses, receipts, and other such information required by City that relate to the performance of services under this Agreement. Consultant shall maintain adequate records of services provided in sufficient detail to permit an evaluation of services. All such records shall be maintained in accordance with generally accepted accounting principles and shall be clearly identified and readily accessible. Consultant shall provide free access to the representatives of City or its designees at reasonable times to review such books and records; shall give City the right to examine and audit said books and records; shall permit City to make transcripts or copies therefrom as necessary; and shall allow inspection of all work, data, documents, proceedings, and activities related to this Agreement. Such records, together with supporting documents, shall be maintained for a period of three (3) years after receipt of final payment. Consultant shall permit auditors of the State of California to examine its records relative to the goods, services, equipment, materials, supplies, or other assistance provided to City under the terms of this Agreement.

(b) Upon completion of, or in the event of termination or suspension of this Agreement, all original documents, designs, drawings, maps, models, computer files, surveys, notes, and other documents prepared in the course of providing the services to be performed pursuant to this Agreement shall become the sole property of the City and may be used, reused, or otherwise disposed of by the City without the permission of the Consultant. However, any use or reuse by City of work product for any purpose other than the original intended purpose and location shall be at Cities sole risk. With respect to computer files, Consultant shall make available to the City, at the Consultant's office, and upon reasonable written request by the City, the necessary computer software and hardware for purposes of accessing, compiling, transferring, copying and/or printing computer files. Consultant hereby grants to City an irrevocable, non-exclusive, non-transferable, royalty-free license in and to the documents, designs, drawings,

maps, models, computer files, surveys, notes, and other documents prepared by Consultant in the course of providing the services under this Agreement. All reports, documents, or other written material developed by Consultant in the performance of the Services pursuant to this Agreement, shall be and remain the property of the City.

## **7. INDEMNIFICATION**

Consultant shall indemnify, defend, and hold the City, and all of its officials, officers, employees, agents, and volunteers harmless from and against any and all liability, claims, suits, actions, damages, and causes of action to the extent arising out of, pertaining or relating to the negligence, recklessness or willful misconduct of Consultant, its employees, subcontractors, or agents, or on account of the performance or character of the Services, except for any such claim arising out of the sole negligence or willful misconduct of the City, its officials, officers, employees, agents, or volunteers. It is understood that the duty of Consultant to indemnify and hold harmless includes the duty to defend as set forth in Section 2778 of the California Civil Code. Notwithstanding the foregoing, for any design professional services, the duty to defend and indemnify the City shall be limited to that allowed pursuant to California Civil Code Section 2782.8. Acceptance of insurance certificates and endorsements required under this Agreement does not relieve Consultant from liability under this indemnification and hold harmless clause. This indemnification and hold harmless clause shall apply whether or not such insurance policies shall have been determined to be applicable to any of such damages or claims for damages. If it is finally adjudicated that liability was caused by the comparative negligence or willful misconduct of an indemnified party, Consultant may submit a claim to the City for reimbursement of reasonable attorneys' fees and defense costs in proportion to the established comparative liability of the indemnified party.

## **8. INSURANCE**

Consultant shall maintain prior to the beginning of and for the duration of this Agreement insurance coverage as specified in Exhibit C attached hereto and incorporated herein by reference.

## **9. INDEPENDENT CONSULTANT**

(a) Consultant is and shall at all times remain as to the City a wholly independent consultant and/or independent contractor. The personnel performing the services under this Agreement on behalf of Consultant shall at all times be under Consultants exclusive direction and control. Neither City nor any of its officers, employees, or agents shall have control over the conduct of Consultant or any of Consultant's officers, employees, or agents, except as set forth in this Agreement. Consultant shall not at any time or in any manner represent that it or any of its officers, employees, or agents are in any manner officers, employees, or agents of the City. Consultant shall not incur or have the power to incur any debt, obligation, or liability whatever against the City, or bind the City in any manner.

(b) No employee benefits shall be available to Consultant in connection with the performance of this Agreement. Except for the fees paid to Consultant as provided in the

Agreement, City shall not pay salaries, wages, or other compensation to Consultant for performing services hereunder for City. City shall not be liable for compensation or indemnification to Consultant for injury or sickness arising out of performing services hereunder.

(c) Consultant shall indemnify, defend and hold harmless, the City, its elected officials, officers, employees and agents, from and against any liability (including liability for claims, suits, actions, arbitration proceedings, administrative proceedings, regulatory proceedings, losses, expenses or costs of any kind, whether actual, alleged or threatened, including contributions to any retirement and/or pension plan, legal counsel fees and costs, court costs, interest, defense costs, and expert witness fees), where the same arise out of, are a consequence of, or are in any way attributable to, in whole or in part, Consultant's or by any individual or agency for which Consultant is legally liable, including but not limited to officers, agents, employees or subconsultants of Consultant, service as an independent contractor. The indemnity provisions set forth in this Section 9 (c) shall survive the termination of this Agreement, and are in addition to any other rights or remedies the City may have under the law.

#### **10. LEGAL RESPONSIBILITIES**

The Consultant shall keep itself informed of State and Federal laws and regulations which in any manner affect those employed by it or in any way affect the performance of its service pursuant to this Agreement. The Consultant shall at all times observe and comply with all such laws and regulations. The City, and its officers and employees, shall not be liable at law or in equity occasioned by failure of the Consultant to comply with this Section.

#### **11. UNDUE INFLUENCE**

Consultant declares and warrants that no undue influence or pressure was used against or in concert with any officer or employee of the City in connection with the award, terms or implementation of this Agreement, including any method of coercion, confidential financial arrangement, or financial inducement. No officer or employee of the City has or will receive compensation, directly or indirectly, from Consultant, or from any officer, employee or agent of Consultant, in connection with the award of this Agreement or any work to be conducted as a result of this Agreement. Violation of this Section shall be a material breach of this Agreement entitling the City to any and all remedies at law or in equity.

#### **12. NO BENEFIT TO ARISE TO LOCAL OFFICERS AND EMPLOYEES**

No member, officer, or employee of City, or their designees or agents, and no public official who exercises authority over or responsibilities with respect to the Project during his/her tenure or for one year thereafter, shall have any interest, direct or indirect, in any agreement or sub-agreement, or the proceeds thereof, for work to be performed in connection with the Project performed under this Agreement.

#### **13. RELEASE OF INFORMATION/CONFLICTS OF INTEREST**

(a) All information gained by Consultant in performance of this Agreement shall be considered confidential and shall not be released by Consultant without City's prior written

authorization. Consultant, its officers, employees, agents, or subconsultants, shall not without written authorization from the City, voluntarily provide declarations, letters of support, testimony at depositions, response to interrogatories, or other information concerning the work performed under this Agreement or relating to any project or property located within the City, unless otherwise required by law or court order.

(b) Consultant shall promptly notify City should Consultant, its officers, employees, agents, or subconsultants be served with any summons, complaint, subpoena, notice of deposition, request for documents, interrogatories, request for admissions, or other discovery request ("Discovery"), court order, or subpoena from any person or party regarding this Agreement and the work performed there under or with respect to any project or property located within the City, unless Consultant is prohibited by law from informing the City of such Discovery, court order or subpoena. City retains the right, but has no obligation, to represent Consultant and/or be present at any deposition, hearing, or similar proceeding as allowed by law. Unless City is a party to the lawsuit, arbitration, or administrative proceeding and is adverse to Consultant in such proceeding, Consultant agrees to cooperate fully with the City and to provide the opportunity to review any response to discovery requests provided by Consultant. However, City's right to review any such response does not imply or mean the right by City to control, direct, or rewrite said response.

#### **14. NOTICES**

Any notices which either party may desire to give to the other party under this Agreement must be in writing and may be given either by (i) personal service, (ii) delivery by a reputable document delivery service, such as but not limited to, Federal Express, which provides a receipt showing date and time of delivery, or (iii) mailing in the United States Mail, certified mail, postage prepaid, return receipt requested, addressed to the address of the party as set forth below or at any other address as that party may later designate by notice:

To City:	City of Industry 15625 Mayor Dave Way City of Industry, CA 91744 Attention: City Manager
With a Copy To:	Casso & Sparks, LLP 13300 Crossroads Parkway North, Suite 410 City of Industry, CA 91746 Attention: James M. Casso, City Attorney
To Consultant:	Mark Thomas & Company, Inc. 2121 N. California Boulevard, Suite 260 Walnut Creek, CA 94596 Attention: Sasha Dansky, Division Manager/Principal

#### **15. ASSIGNMENT**

The Consultant shall not assign the performance of this Agreement, nor any part thereof, nor any monies due hereunder, without prior written consent of the City.

Before retaining or contracting with any subconsultant for any services under this Agreement, Consultant shall provide City with the identity of the proposed subconsultant, a copy of the proposed written contract between Consultant and such subconsultant which shall include and indemnity provision similar to the one provided herein and identifying City as an indemnified party, or an incorporation of the indemnity provision provided herein, and proof that such proposed subconsultant carries insurance at least equal to that required by this Agreement or obtain a written waiver from the City for such insurance.

Notwithstanding Consultant's use of any subconsultant, Consultant shall be responsible to the City for the performance of its subconsultant as it would be if Consultant had performed the Services itself. Nothing in this Agreement shall be deemed or construed to create a contractual relationship between the City and any subconsultant employed by Consultant. Consultant shall be solely responsible for payments to any subconsultants. Consultant shall indemnify, defend and hold harmless the Indemnified Parties for any claims arising from, or related to, the services performed by a subconsultant under this Agreement.

**16. GOVERNING LAW/ATTORNEYS' FEES**

The City and Consultant understand and agree that the laws of the State of California shall govern the rights, obligations, duties, and liabilities of the parties to this Agreement and also govern the interpretation of this Agreement. Any litigation concerning this Agreement shall take place in the municipal, superior, or federal district court in Los Angeles County, California. If any action at law or suit in equity is brought to enforce or interpret the provisions of this Agreement, or arising out of or relating to the Services provided by Consultant under this Agreement, the prevailing party shall be entitled to reasonable attorneys' fees and all related costs, including costs of expert witnesses and consultants, as well as costs on appeal, in addition to any other relief to which it may be entitled.

**17. ENTIRE AGREEMENT**

This Agreement contains the entire understanding between the Parties relating to the obligations of the Parties described in this Agreement. All prior or contemporaneous agreements, understandings, representations, and statements, oral or written and pertaining to the subject of this Agreement or with respect to the terms and conditions of this Agreement, are merged into this Agreement and shall be of no further force or effect. Each party is entering into this Agreement based solely upon the representations set forth herein and upon each party's own independent investigation of any and all facts such party deems material.

**18. SEVERABILITY**

If any term or provision of this Agreement or the application thereof to any person or circumstance shall, to any extent, be invalid or unenforceable, then such term or provision shall be amended to, and solely to, the extent necessary to cure such invalidity or unenforceability, and in its amended form shall be enforceable. In such event, the remainder of this Agreement, or the application of such term or provision to persons or circumstances other than those as to which it is held invalid or unenforceable, shall not be affected thereby, and each term and provision of this Agreement shall be valid and be enforced to the fullest extent permitted by law.

**19. COUNTERPARTS**

This Agreement may be executed in multiple counterparts, each of which shall be deemed an original, but all of which taken together shall constitute one and the same instrument.

**20. CAPTIONS**

The captions appearing at the commencement of the sections hereof, and in any paragraph thereof, are descriptive only and shall have no significance in the interpretation of this Agreement.

**21. WAIVER**

The waiver by City or Consultant of any breach of any term, covenant or condition herein contained shall not be deemed to be a waiver of such term, covenant or condition or of any subsequent breach of the same or any other term, covenant or condition herein contained. No term, covenant or condition of this Agreement shall be deemed to have been waived by City or Consultant unless in writing.

**22. REMEDIES**

Each right, power and remedy provided for herein or now or hereafter existing at law, in equity, by statute, or otherwise shall be cumulative and shall be in addition to every other right, power, or remedy provided for herein or now or hereafter existing at law, in equity, by statute, or otherwise. The exercise, the commencement of the exercise, or the forbearance of the exercise by any party of any one or more of such rights, powers or remedies shall not preclude the simultaneous or later exercise by such party of any of all of such other rights, powers or remedies.

**23. AUTHORITY TO EXECUTE THIS AGREEMENT**

The person or persons executing this Agreement on behalf of Consultant represents and warrants that he/she has the authority to execute this Agreement on behalf of the Consultant and has the authority to bind Consultant to the performance of its obligations hereunder.

IN WITNESS WHEREOF, the Parties hereto have caused this Agreement to be executed as of the Effective Date.

(Signatures on the following page)

**“CITY”**  
City of Industry

**“CONSULTANT”**  
Mark Thomas & Company, Inc.

By: \_\_\_\_\_  
Joshua Nelson, City Manager

By: \_\_\_\_\_  
Sasha Dasky, Division Manager/Principal

**Attest:**

By: \_\_\_\_\_  
Julie Gutierrez-Robles, City Clerk

**Approved as to form:**

By: \_\_\_\_\_  
James M. Casso, City Attorney

Attachments:	Exhibit A	Scope of Services
	Exhibit B	Rate Schedule
	Exhibit C	Insurance Requirements

## EXHIBIT A

### SCOPE OF SERVICES

This scope is in support of the City's Wildlife Conservation Board grant funded Follows Camp Ecological Design and Implementation Project ("Project"). The scope described here comprises Part 1 of the overall project, including Master Planning and Conceptual Designs. The remaining elements of the project will be developed at the conclusion of Part 1 and be provided as Part 2, including 60 percent -100 percent designs and basis of design report.

#### **TASK 2. SITE ACTIVATION & MASTER PLANNING**

This task will result in an overall plan for the 118-acre site, including a long-term vision, phasing, entitlement strategy, and physical site plan combining restoration, educational, environmental stewardship, Japchivit village cultural, and access program elements.

##### ***Low-water Crossing/Bridge Site Selection Subtask:***

Consultant will participate in stakeholder engagement meetings to support the evaluation of alternative bridge crossing sites and selection of the preferred alternative. General bridge design parameters (bridge height, width, level of service, approach design parameters) will be provided to support this process. This shall also include an assessment of the overall feasibility and suitability of different bridge designs to meet the functional, aesthetic and environmental objectives of the project, including a relative comparison of costs between bridge type options. Consultant will define and undertake preliminary design studies such as geomorphic, geotechnical evaluation or other surveys, and seismic analysis needed in support of the bridge site selection and design. Parameters for planning and re-design of the low-water crossing will be incorporated into the design by Consultant. Sensitivity to existing landforms, vegetation, and views will be emphasized in site selection evaluation studies.

##### **Assumptions:**

- Consultant will develop conceptual design alternatives, including locations for bridge, bridge approaches, and low water crossing options. Preferred bridge, bridge approaches, and low water crossing concepts will accommodate fish passage, natural fluvial geomorphological processes, sensitive grading and view considerations, and the preferred site access plans, which may include vehicular crossing.
- Consultant will collaborate with the master planning, civil engineering, and biological assessment team to provide input on the bridge design responds to other design and environmental constraints of the project.
- All work related to the technical feasibility, design and construction of the bridge and low water crossing are to be based on Consultant's independent analysis and assessment of existing and proposed conditions.
- Consultant will participate in a maximum of three (3) stakeholder engagement meetings.
- Consultant will participate in internal design team meetings as appropriate.

**Deliverables:**

- Participation in regular stakeholder engagement meetings
- Technical memorandum providing an overview of bridge type and design options and suitability for project objectives.
- Concept-level general plan sheets showing bridge alignment alternatives (assume a total of 3 for bridge and low water crossing)

**TASK 3. DESIGN & PERMITTING PART 1*****Subtask 3b. Bridge and Low Water Crossing Design***

Thirty five percent design level structural plan sheets will be prepared for a bridge and a low water crossing. Bridge design will include a structure that will accommodate autos, non-motorized, and/or pedestrian use as appropriate.

- The bridge design will accommodate vehicular traffic and 100-year flood flows, sediment transport, fish passage and natural geomorphic processes supporting habitat complexity within the floodplain.
- Low-water crossing re-design will accommodate fish passage, increased habitat complexity within the floodplain and natural geomorphic processes.
- The bridge design will include minor roadway design elements such as preliminary plans for road improvements needed at the bridge and low-water approaches.
- Bridge and low water crossing designs will emphasize sensitivity to landforms, vegetation, and views through sensitive grading strategies for bridge approaches, bridge placement, and bridge type selection.
- The plans will be accompanied by a basis of design (BOD) report including all background, existing conditions, and surveys and a summary of the design approach and assumptions that informed the 35 percent design. The BOD will also include a summary of import and export volumes as well as a description of construction disturbances (such as total area of disturbance), estimated total truck trips and an engineer's opinion of probable construction cost for the bridge and low water crossing.
- Consultant will engage Crawford & Associates Inc. (Crawford) as a geotechnical sub-consultant to prepare preliminary foundation reports in support of the different alternatives to be included in the BOD report. Consultant will work in close collaboration with Crawford to develop foundation alternatives that are sensitive environmental conditions for work inside the river. Crawford's scope of work will consist of completing a field review to assess the current project site conditions, reviewing readily available project site mapping and any geotechnical data available for the site. Crawford will prepare a Preliminary Foundation Report per Caltrans guidelines.

**Assumptions:**

- Consultant will be engineer of record for structural design elements informing the analysis and design of crossing and bridge and roadway approaches.
- It is assumed that the vertical and horizontal alignments for the various structure alternatives are to be developed and provided by others in Task 2 Master Plan.
- Consultant will develop 35 percent designs for the Master Plan Phase 1 roadway connections to the bridge and low water crossing. Consultant will support others in the conceptual design of the intersection at East Fork Road.
- Conceptual or preliminary design of additional transportation structures that may be required during final design of the project, such as retaining walls, are not included in this Task.
- Consultant may utilize, at their discretion, as to the accuracy and relevance to the bridge design, materials, models and calculations undertaken by Stillwater such as hydraulic models.
- Site study tasks including additional geotechnical exploration and analysis in support of a Final Foundation Report may be deferred to Part 2 pending project needs. Funds for deferred tasks will be held and applied to Part 2 budget.
- Engineer's construction cost estimates will be level 3 (conceptual), as defined by AACE International (Association for the Advancement of Cost Engineering).

**Deliverables:**

- Bridge and low-water crossing components of the 35percent Basis of Design Report including structural plan sheets, Preliminary Foundation Report, and concept-level cost estimates for a bridge and a low-water crossing.

**TIMELINE AND DELIVERABLES PART 1**

Task	Task	Deliverables	Expected Start Date	Expected Completion Date
2	Site Activation and Master Planning	<ul style="list-style-type: none"> <li>• Site Master Plan Document</li> </ul>	5/1/2025	2/1/2027
3	Design and Permitting Part 1		5/1/2025	2/1/2027
3b.	Bridge and Low Water Crossing Design	<ul style="list-style-type: none"> <li>• 35percent Design Plans, Basis of Design Report, Preliminary Foundation Report, and concept- level cost estimates</li> </ul>		

## EXHIBIT B

### RATE SCHEDULE

The work is funded in the approved FY 24-25 Capital Improvement Project budget under Account No. 120-726-5130. (MP 11-09 #1)

#### **Engineering**

Intern	\$65 - \$110
Technician	\$95 - \$135
Design Engineer I	\$125 - \$175
Design Engineer II	\$140 - \$220
Sr. Technician	\$160 - \$215
Civil Engineering Designer	\$170 - \$260
Project Engineer	\$170 - \$240
Sr. Project Engineer	\$210 - \$300
Sr. Technical Engineer	\$220 - \$245
Technical Lead	\$245 - \$300
Sr. Technical Lead	\$285 - \$355
Design Manager	\$365 - \$405
Engineering Manager	\$365 - \$405
Sr. Engineering Manager	\$370 - \$495

#### **Construction Management**

Office Engineer	\$170 - \$270
* Asst. Resident Engineer	\$240 - \$270
* Inspector - CM	\$195 - \$275
Resident Engineer	\$310 - \$345
Sr. Resident Engineer	\$350 - \$385
Area Manager - CM	\$270 - \$305

#### **Planning**

Planner I	\$110 - \$140
Planner II	\$155 - \$175
Sr. Planner	\$170 - \$235

#### **Landscape Architecture/Urban Design**

Landscape Intern	\$90 - \$105
Landscape Designer I	\$115 - \$130
Landscape Designer II	\$135 - \$170
Landscape Architect	\$160 - \$195
Sr. Landscape Architect	\$185 - \$210

#### **Grant Writing**

Funding Specialist	\$140 - \$255
Sr. Funding Specialist	\$260 - \$305
Funding Manager	\$335 - \$390

#### **Surveying**

Survey Technician I-III	\$65 - \$185
Lead Survey Technician	\$145 - \$165
Survey Specialist I-III	\$135 - \$280
Asst Surveyor I-III	\$140 - \$200
Project Surveyor I-III	\$200 - \$305
* Chief of Party	\$205 - \$255
* Instrumentperson	\$205 - \$230
* Chainperson	\$205 - \$215
* Apprentice	\$130 - \$185
* 2-Person Crew	\$375 - \$455
* 3-Person Crew	\$570 - \$675
* Utility Locator	\$190 - \$250
Drone	\$275

#### **Project Management & Oversight**

Project Manager	\$250 - \$335
Sr. Project Manager	\$280 - \$380
Survey Manager I-II	\$240 - \$410
SUE Program Manager	\$285 - \$315
Division Manager	\$290 - \$420
Principal	\$480 - \$520

#### **Project Support**

Technical/Sr. Technical Writer	\$120 - \$160
Project/Sr. Project Assistant	\$85 - \$175
Project/Sr. Project Coordinator	\$130 - \$215
Graphic/Sr. Graphic Designer	\$135 - \$235
Project Accountant	\$125 - \$195
Sr. Graphic Manager	\$215 - \$275
Project Accountant Manager	\$225 - \$255

#### **District Management**

* Inspector - Apprentice	\$95 - \$110
* Inspector/Sr. Inspector	\$110 - \$195
Assistant/Associate Sanitary Engineer	\$160 - \$235
Sanitary/Sr. Sanitary Project Engineer	\$210 - \$300
Operations/Deputy District Manager	\$270 - \$385
District Manager-Engineer	\$395 - \$440

#### **Special Services**

Expert Witness	\$520
Strategic Consulting	\$520

Reimbursables including, but not limited to; reproductions, delivery and filing fees, at cost only; Subconsultant fees, at cost only. Mileage will be billed per current IRS Rate to Follows Camp project only.

Rates are effective through June 30, 2025, after which current Rate Schedule will be submitted.

## EXHIBIT C

### INSURANCE REQUIREMENTS

Without limiting Consultant's indemnification of City, and prior to commencement of the Services, Consultant shall obtain, provide and maintain at its own expense during the term of this Agreement, policies of insurance of the type and amounts described below and in a form satisfactory to City.

**General liability insurance.** Consultant shall maintain commercial general liability insurance with coverage at least as broad as Insurance Services Office form CG 00 01, in an amount not less than \$1,000,000.00 per occurrence, \$2,000,000.00 general aggregate, for bodily injury, personal injury, and property damage. The policy must include contractual liability that has not been amended. Any endorsement restricting standard ISO "insured contract" language will not be accepted.

**Automobile liability insurance.** Consultant shall maintain automobile insurance at least as broad as Insurance Services Office form CA 00 01 covering bodily injury and property damage for all activities of the Consultant arising out of or in connection with Work to be performed under this Agreement, including coverage for any owned, hired, non-owned or rented vehicles, in an amount not less than \$1,000,000.00 combined single limit for each accident.

**Professional liability (errors & omissions) insurance.** Consultant shall maintain professional liability insurance that covers the Services to be performed in connection with this Agreement, in the minimum amount of \$1,000,000 per claim and in the aggregate. Any policy inception date, continuity date, or retroactive date must be before the effective date of this agreement and Consultant agrees to maintain continuous coverage through a period no less than three years after completion of the services required by this agreement.

**Workers' compensation insurance.** Consultant shall maintain Workers' Compensation Insurance (Statutory Limits) and Employer's Liability Insurance (with limits of at least \$1,000,000.00).

Consultant shall submit to City, along with the certificate of insurance, a Waiver of Subrogation endorsement in favor of City, its officers, agents, employees and volunteers.

**Proof of insurance.** Consultant shall provide certificates of insurance to City as evidence of the insurance coverage required herein, along with a waiver of subrogation endorsement for workers' compensation. Insurance certificates and endorsement must be approved by City's Risk Manager prior to commencement of performance. Current certification of insurance shall be kept on file with City at all times during the term of this contract. City reserves the right to require complete, certified copies of all required insurance policies, at any time.

**Duration of coverage.** Consultant shall procure and maintain for the duration of the contract insurance against claims for injuries to persons or damages to property, which may arise from or in connection with the performance of the Services hereunder by Consultant, his agents, representatives, employees or subconsultants.

**Primary/noncontributing.** Coverage provided by Consultant shall be primary and any insurance or self-insurance procured or maintained by City shall not be required to contribute with it. The limits of insurance required herein may be satisfied by a combination of primary and umbrella or excess insurance. Any umbrella or excess insurance shall contain or be endorsed to contain a provision that such coverage shall also apply on a primary and non-contributory basis for the benefit of City before the City's own insurance or self-insurance shall be called upon to protect it as a named insured.

**City's rights of enforcement.** In the event any policy of insurance required under this Agreement does not comply with these specifications or is canceled and not replaced, City has the right but not the duty to obtain the insurance it deems necessary and any premium paid by City will be promptly reimbursed by Consultant, or City will withhold amounts sufficient to pay premium from Consultant payments. In the alternative, City may cancel this Agreement.

**Acceptable insurers.** All insurance policies shall be issued by an insurance company currently authorized by the Insurance Commissioner to transact business of insurance in the State of California, with an assigned policyholders' Rating of A- (or higher) and Financial Size Category Class VI (or larger) in accordance with the latest edition of Best's Key Rating Guide, unless otherwise approved by the City's Risk Manager.

**Waiver of subrogation.** All insurance coverage maintained or procured pursuant to this agreement shall be endorsed to waive subrogation against City, its elected or appointed officers, agents, officials, employees and volunteers or shall specifically allow Consultant or others providing insurance evidence in compliance with these specifications to waive their right of recovery prior to a loss. Consultant hereby waives its own right of recovery against City, and shall require similar written express waivers and insurance clauses from each of its subconsultants.

**Enforcement of contract provisions (non estoppel).** Consultant acknowledges and agrees that any actual or alleged failure on the part of the City to inform Consultant of non-compliance with any requirement imposes no additional obligations on the City nor does it waive any rights hereunder.

**Requirements not limiting.** Requirements of specific coverage features or limits contained in this Section are not intended as a limitation on coverage, limits or other requirements, or a waiver of any coverage normally provided by any insurance. Specific reference to a given coverage feature is for purposes of clarification only as it pertains to a given issue and is not intended by any party or insured to be all inclusive, or to the exclusion of other coverage, or a waiver of any type. If the Consultant maintains higher limits than the minimums shown above, the City requires and shall be entitled to coverage for the higher limits maintained by the Consultant. Any available insurance proceeds in excess of the specified minimum limits of insurance and coverage shall be available to the City.

**Notice of cancellation.** Consultant agrees to oblige its insurance agent or broker and insurers to provide to City with a thirty (30) day notice of cancellation (except for nonpayment for which a ten (10) day notice is required) or nonrenewal of coverage for each required coverage.

**Additional insured status.** General liability policies shall provide or be endorsed to provide that City and its officers, officials, employees, and agents, and volunteers shall be additional insureds under such policies. This provision shall also apply to any excess liability policies.

**Prohibition of undisclosed coverage limitations.** None of the coverages required herein will be in compliance with these requirements if they include any limiting endorsement of any kind that has not been first submitted to City and approved of in writing.

**Separation of Insureds.** A severability of interests provision must apply for all additional insureds ensuring that Consultant's insurance shall apply separately to each insured against whom claim is made or suit is brought, except with respect to the insurer's limits of liability. The policy(ies) shall not contain any cross-liability exclusions.

**Pass Through Clause.** Consultant agrees to ensure that its subconsultants, subcontractors, and any other party involved with the project who is brought onto or involved in the project by Consultant, provide the same minimum insurance coverage and endorsements required of Consultant. Consultant agrees to monitor and review all such coverage and assumes all responsibility for ensuring that such coverage is provided in conformity with the requirements of this section. Consultant agrees that upon request, all agreements with consultants, subcontractors, and others engaged in the project will be submitted to City for review.

**City's right to revise specifications.** The City reserves the right at any time during the term of the contract to change the amounts and types of insurance required by giving the Consultant ninety (90) days advance written notice of such change. If such change results in substantial additional cost to the Consultant, the City and Consultant may renegotiate Consultant's compensation.

**Self-insured retentions.** Any self-insured retentions must be declared to and approved by the City. The City reserves the right to require that self-insured retentions be eliminated, lowered, or replaced by a deductible. Self-insurance will not be considered to comply with these specifications unless approved by the City.

**Timely notice of claims.** Consultant shall give the City prompt and timely notice of claims made or suits instituted that arise out of or result from Consultant's performance under this Agreement, and that involve or may involve coverage under any of the required liability policies.

**Additional insurance.** Consultant shall also procure and maintain, at its own cost and expense, any additional kinds of insurance, which in its own judgment may be necessary for its proper protection and prosecution of the work.

ITEM NO. 6.9



# CITY OF INDUSTRY

## MEMORANDUM

**TO:** Honorable Mayor and Members of the City Council

**FROM:** Joshua Nelson, City Manager

**STAFF:** Mathew Hudson, Director of Public Works  
James Cramsie, Sr. Director of Engineering

**DATE:** April 24, 2025

**SUBJECT:** Consideration of Amendment No. 3 to the Professional Services Agreement with Kleinfelder, Inc., for on-call geotechnical engineering services, extending the term through April 30, 2028, revising the rate schedule, and increasing compensation by \$400,000.00

---

### Background:

On April 8, 2021, the City Council approved a Professional Services Agreement (“Agreement”) with Kleinfelder, Inc., in the amount of \$500,000.00 for on-call geotechnical services on future capital improvement projects. Kleinfelder provides evaluations on existing street pavement and subgrades, pavement section recommendations, recommendations for street rehabilitation and reconstruction, geotechnical observation and testing during construction, and construction materials observation and testing.

On May 27, 2021, the City Council approved Amendment No. 1 to the Agreement, amending the rate schedule to include payment for services specific to materials laboratory testing and equipment charges that were mistakenly omitted from the original Agreement. On February 6, 2023, the City Council approved Amendment No. 2 to the Agreement, extending the term through April 7, 2025, increasing compensation by \$400,000.00, and updating the address for the City.

### Discussion:

Kleinfelder has been providing geotechnical services on a variety of Capital Improvement projects, including:

- Arenth Avenue Reconstruction
- Annual Slurry Seal project
- Sixth Avenue Reconstruction
- Four Grade Separation Pump Stations

- Gale Avenue Resurfacing
- Stimson Avenue Crossing at LA Subdivision
- Rowland Street Reconstruction
- Nelson Avenue Reconstruction

Due to the volume of projects that Kleinfelder has worked on, it is necessary to amend the Agreement to extend the term of the Agreement through April 30, 2028, along with a companion increase in compensation of \$400,000.00 to continue providing geotechnical services on CIP projects. Additionally, it is necessary to revise the rate schedule to include Kleinfelder's current rates.

**Fiscal Impact:**

The fiscal impact associated with Amendment No. 3 is \$400,000.00. This will be funded by the approved projects in the Capital Improvement Project budget for Fiscal Year 2025-2026.

**Recommendation:**

Staff recommends that the City Council approve Amendment No. 3 to the Agreement with Kleinfelder

**Exhibits:**

1. Amendment No. 3 to the Professional Services Agreement with Kleinfelder, Inc., dated April 24, 2025

**AMENDMENT NO. 3  
TO PROFESSIONAL SERVICES AGREEMENT WITH KLEINFELDER, INC.**

This Amendment No. 3 to the Professional Services Agreement (“Agreement”), is made and entered into this 24<sup>th</sup> day of April, 2025 (“Effective Date”), by and between the City of Industry, a California municipal corporation (“City”) and Kleinfelder, Inc., a California corporation (“Consultant”) (“Consultant”). The City and Consultant are hereinafter collectively referred to as the “Parties.”

**RECITALS**

**WHEREAS**, on or about April 8, 2021, the Agreement was entered into and executed between the City and Consultant for on-call geotechnical engineering services; and

**WHEREAS**, on or about May 27, 2021, Amendment No. 1 was approved to amend the rate schedule to include payment for materials laboratory testing and equipment charges that were omitted from the original Agreement; and

**WHEREAS**, on or about February 6, 2023, Amendment No. 2 was approved to extend the term through April 7, 2025, increasing compensation by \$400,000.00, and updating the address for the City; and

**WHEREAS**, the Agreement expired on April 7, 2025, and it is necessary to amend the Agreement to extend the term through April 30, 2028 to allow Consultant to continue to provide on-call geotechnical services on various Capital Improvement Projects in the City. Additionally, it is necessary to revise the rate schedule for Consultant’s current rates, and provide a companion increase in compensation of \$400,000.00 for the extension; and

**WHEREAS**, for the reasons set forth herein, the City and Consultant desire to enter into this Amendment No. 3, as set forth below.

**AMENDMENT**

**NOW, THEREFORE**, in consideration of the mutual covenants, promises and agreements set forth herein, it is agreed the aforesaid Agreement, a copy of which is attached hereto as Exhibit A, and incorporated herein by reference, shall remain in full force and effect except as otherwise hereinafter provided:

**1. TERM**

Section 1, Term, is hereby revised to read in its entirety as follows:

This Agreement shall commence on April 8, 2025, and shall remain and continue in effect until tasks described herein are completed, but in no event later than April 30, 2028, unless sooner terminated pursuant to the provisions of this Agreement.

**4. PAYMENT**

The second sentence of Section 4. Payment, is hereby revised to read in its entirety as follows:

This amount shall not exceed One Million Three Hundred Thousand Dollars (\$1,300,000.00), for the total Term of the Agreement, unless additional payment is approved as provided in this Agreement.

**EXHIBIT B, RATE SCHEDULE**

The Rate Schedule is hereby rescinded in its entirety and replaced with rates set forth in Attachment 1, attached hereto and incorporated herein by reference.

The person or persons executing this Agreement on behalf of Consultant represents and warrants that he/she has the authority to execute this Agreement on behalf of the Consultant and has the authority to bind Consultant to the performance of its obligations hereunder.

**IN WITNESS WHEREOF**, the Parties have executed this Amendment No. 3 to the Agreement as of the Effective Date.

**“CITY”  
CITY OF INDUSTRY**

**“CONSULTANT”  
KLEINFELDER, INC.**

By: \_\_\_\_\_  
Joshua Nelson, City Manager

By: \_\_\_\_\_  
Mark Peabody, Los Angeles Area  
Manager, Vice President

**Attest:**

By: \_\_\_\_\_  
Julie Gutierrez-Robles, City Clerk

**APPROVED AS TO FORM**

By: \_\_\_\_\_  
James M. Casso, City Attorney

**ATTACHMENT 1  
EXHIBIT B  
RATE SCHEDULE**

**PROFESSIONAL STAFF RATES\***

Professional .....	\$ 149 / hour
Staff Professional .....	\$ 178 / hour
Project Professional .....	\$ 202 / hour
Senior Professional .....	\$ 221 / hour
Principal Professional .....	\$ 268 / hour
Project Manager .....	\$ 221 / hour
Senior Project Manager.....	\$ 268 / hour
Designer/Drafter .....	\$ 137 / hour
Senior Designer/Drafter.....	\$ 149 / hour
Project Controls Professional .....	\$ 137 / hour

**ADMINISTRATIVE STAFF RATES\***

Administrator .....	\$ 102 / hour
Project Administrator .....	\$ 143 / hour

Minimum Charges for Office Time Per Day..... One Hour at  
Applicable Rate

**TECHNICIAN STAFF RATES**

The technician rates below are based upon the DIR rates required to be paid by Kleinfelder to our onsite technicians. The PW rates are based on the date of service and we have kept the approximate percentage of rate increase the same as from the initial contract date of April 8, 2021.

Prevailing Wage Technician (Amendment Authorization Date to 12/31/2025) .....	\$ 156 / hour
Prevailing Wage Technician (1/1/2026 to 12/31/2026).....	\$ 163 / hour
Prevailing Wage Technician (1/1/2027 to 12/31/2027).....	\$ 169 / hour
Prevailing Wage Technician (1/1/2028 to 12/31/2028).....	\$ 176 / hour
Technician (Non Prevailing Wage) .....	\$ 107 / hour

The rates presented above are applicable from April 9, 2025 to December 31, 2025. As of January 1, 2026, the Professional and Administrative rates, and the Non-Prevailing Wage Technician rate, will increase by 4 percent. The Prevailing Wage rate will increase as shown above. Public works projects or projects receiving public funds may be subject to Prevailing Wage laws. The Professional and Administrative rates above do not apply to projects subject to prevailing wages. Hourly rates for those projects are presented above. The Prevailing Wage Technician rates presented above are based on the current DIR Rate applicable. The Prevailing Wage Technician Rate will be increased as shown above based on the DIR rate. The rates above will be effective upon the date of Amendment approval from the City of Industry.

\* Applies to all professional rates including but not limited to civil, mechanical, chemical, electrical, geotechnical, and environmental engineers; industrial hygienists; geologists; hydrogeologists; hydrologists; and computer specialists.

Hourly rates assume that other direct costs will be billed and reimbursed by the client.

### EQUIPMENT RATES

Equipment	Invoice Name	Test Method <sup>†</sup>	Price
Anchor Bolt Testing Device	ANCHOR BOLT TST/DAY		\$150.00 / day
Brinell Hardness Tester	BRINELL HARDNESS/DAY	E10	\$20.00 /day
Concrete Rebound (Schmidt) Hammer	SCHMIDT HAMMER/DAY	C805	\$55.00 / day
Concrete Vapor Emission Test Kit	MOIST FLOOR/SLAB TST	F1869	\$30.00 / kit
Coring Machine	CORING MACHINE /DAY		\$85.00 /day
Coring Machine with Generator	CORING MCH W/GEN DAY		\$165.00 / day
Cylinder Mold	CYLINDER MOLDS		\$3.00 each
Diamond Bit Core Barrel Charge			
3" Diameter	CORING, 3" DIAM./IN		\$3.30 / inch
4" Diameter	CORING, 4" DIAM./IN		\$4.40 / inch
6" Diameter	CORING, 6" DIAM./IN		\$6.60 / inch
Digital Thickness Gauge	THICKNESS GAUGE /DAY		\$50.00 /day
Equipment Transport Fee	EQUIPMENT TRANSPORT		\$76.00 /day
FerroScan Equipment	FERROSCAN EQUIPMENT		\$275.00 /day
Floor Flatness Testing Device (Per Sq Ft)	FLOOR FLATNESS /SF	E1155	\$0.10 /sq ft
Floor Flatness Testing Device (Per Test)	FLOOR FLATNESS TST	E1155	\$150.00 / day
Hand Auger and Soil Sampler	HAND AUGER/DAY		\$75.00 /day
Magnetic Particle Testing Device	MAGNETIC PARTICLE	ASNT, AWS B1.1	\$45.00 /day
Nuclear Soil Density/Moisture Gauge	NUCLEAR DENS GAUGE	D6938	\$75.00 / day
Skidmore Bolt Tension Calibrator	SKID WILH BOLT/DAY	A325, A490	\$55.00 / day
Torque Wrench, up to 1,000 foot-pounds	TORQUE WRENCH/DAY	A325, A490	\$50.00 / day
Ultrasonic Testing Device	UT TESTING EQUIP/DAY	ASNT, AWS B1.1	\$75.00 /day

### SOIL DENSITY TESTS

Test	Standard Test Method <sup>†</sup>	Fee		
		\$		
Standard Proctor	D698, T99	\$	305	each
Modified Proctor	D1557, T180	\$	305	each
Rapid Determination of Compaction*	D5080	\$	250	each
1-Point Proctor, Check Point	T272	\$	180	each
Proctor Oversize Correction	D4718	\$	95	each
Treated Soil Proctor	D558	\$	400	each
Minimum and Maximum Relative Density	D4254, D4253	\$	535	each
Maximum Density by Vibratory Hammer	D7382	\$	695	each
Moisture/Density, TEX 113-E	TEX113-E	\$	345	each
Moisture/Density, TEX 114-E	TEX114-E	\$	345	each
California Impact, CT 216	CT216	\$	285	each
<i>*Field Test</i>				

<b>SOIL CLASSIFICATION AND INDEX TESTS</b>				
<b>Test</b>	<b>Standard Test Method†</b>	<b>Fee</b>		
Visual Classification	D2488	\$	37	each
Sieve Analysis, % Finer than No. 200 Sieve	D1140	\$	115	each
Sieve Analysis, Fine	D422, D6913, T88	\$	165	each
Sieve Analysis, Coarse	D422, D6913, T88	\$	165	each
Sieve Analysis, Coarse and Fine	D422, D6913, T88	\$	210	each
Hydrometer Analysis ( <i>Requires a Sieve Analysis, not included</i> )	D422, D7928	\$	230	each
Water Content	D2216, D4363, T265	\$	32	each
Water Content and Dry Unit Weight	D2216, D2937, D7263	\$	58	each
Atterberg Limits, Single Point	D4318-B, T89, T90	\$	150	each
Atterberg Limits, Multiple Point	D4318-A, T89, T90	\$	230	each
Soil Specific Gravity	D854, T100	\$	285	each
Soil Organic Content	D2974-C	\$	160	each
Fiber Content of Peat Soils	D1997	\$	335	each
Pinhole Dispersion Classification	D4647	\$	660	each
Soil pH	D4972, G51	\$	74	each
Double Hydrometer for Dispersive Soils	D4221	\$	345	each
Crumb Test for Dispersive Soils	D6572	\$	110	each
Soil Resistivity	G187	\$	200	each
Chloride Content		\$	89	each
Sulfate Content		\$	74	each
Thermal Resistivity, Per Point	D5334, IEEE 422	\$	410	each
Thermal Resistivity, Dry-Out Curve	D5334, IEEE 422	\$	1,195	each
Methylene Blue	C837	\$	290	each

<b>SOIL BEARING PRESSURE TESTS</b>				
<b>Test</b>	<b>Standard Test Method†</b>	<b>Fee</b>		
California Bearing Ratio, Single Point ( <i>proctor not included</i> )	D1883, T193	\$	440	each
California Bearing Ratio, 3 Points ( <i>proctor not included</i> )	D1883, T193	\$	820	each
Resistance R-Value	D2844	\$	410	each
Resistance R-Value of Treated Material	D2844	\$	475	each
Rock Correction for R-Value	D2844	\$	105	each
Stabilized Soil UC Strength, 1 Point ( <i>proctor not included</i> )	D1633, D5102	\$	220	each
Stabilized Soil UC Strength, Set of 3	D1633, D5102	\$	1,195	each
CT373, 1 Lime Content, w/o Opt. Moist.	CT373	\$	210	each
CT373, 1 Lime Content	CT373	\$	460	each
CT373, 3 Lime Contents	CT373	\$	1,385	each
Eades and Grim Test (Opt. Lime Content)	C977	\$	245	each
Resilient Modulus	T307	\$	600	each
CTB Strength, Individual Specimen		\$	230	each
CTB Strength, Set of 3, Without Design		\$	525	each
CTB Complete Mix Design		\$	Inquire	each

<b>SOIL STRENGTH AND PERMEABILITY TESTS</b>				
<b>Test</b>	<b>Standard Test Method†</b>	<b>Fee</b>		
Pocket Penetration Value		\$	37	each
Unconfined Compressive Strength	D2166, T208	\$	180	each
Direct Shear, 1 Point	D3080, T236	\$	190	each
Direct Shear, 3 Points	D3080, T236	\$	495	each
Direct Shear, Residual Strength, Each Point	D3080-Modified	\$	315	each
Consolidation without Time Rate Plots	D2435-Modified	\$	430	each

Consolidation with 2 Time Rate Plots	D2435-A, T216-A	\$	565	each
Consolidation, All Loads with Time Rates	D2435-B, T216-B	\$	800	each
Collapse Potential	D5333	\$	315	each
One Dimensional Swell – Wetting After Loading, Series	D4546-A	\$	380	each
One Dimensional Swell – Wetting After Loading	D4546-B	\$	220	each
One Dimensional Swell – Loading After Wetting	D4546-C	\$	600	each
Expansion Index	D4829	\$	245	each
Denver Swell Test		\$	220	each
Permeability, Rigid Wall	D2434	\$	565	each
Permeability, Flexible Wall	D5084-C	\$	495	each
Triaxial Compression, CU, 1 Point	D4767, T297	\$	630	each
Triaxial Compression, CU, 3 Points	D4767, T297	\$	1,560	each
Triaxial Compression, UU, 1 Point	D2850, T296	\$	265	each
Triaxial Compression, UU, 3 Points	D2850, T296	\$	800	each
Triaxial Compression, UU Saturated, 1 Point	D2850-Modified	\$	380	each
Triaxial Test, TEX117E, Part I	TEX117E	\$	2,250	each
Triaxial Test, TEX117E, Part II	TEX117E	\$	2,250	each
Vane Shear – Motorized	D4648	\$	100	each

### ROCK TESTS

Test	Standard Test Method†	Fee		
Rock Sample Preparation	D4543	\$	150	each
Rock Mohs Hardness	IRSM	\$	100	each
Rock Point Load Index, per Point*	D5731	\$	68	each
Rock Slake Durability	D4644	\$	250	each
Rock Splitting Tensile/Brazilian, per Point*	D3967	\$	125	each
Rock Direct Tensile	D2936	\$	250	each
Rock Unconfined Compression	D7012-C	\$	315	each
<i>Above testing fees include routine sample preparation (end grinding) and sample photographs.</i>				
<i>*Point load and splitting tensile test fees are per break, not per set of ten.</i>				

### AGGREGATE TESTS

Test	Standard Test Method†	Fee		
ASR Reactivity, Long Method	C227, C1293	\$	2,135	each
ASR Reactivity, Short Method	C1260, C1567	\$	1,195	each
Cleanness Value	CT227	\$	210	each
Clay Lumps and Friable Particles, per size *(see note below)	C142, T112	\$	130	each
Coarse Specific Gravity & Absorption	C127, T85	\$	125	each
Fine Specific Gravity & Absorption	C128, T84	\$	185	each
Coarse Durability	D3744, T210	\$	190	each
Fine Durability	D3744, T210	\$	190	each
Flat and Elongated Particles, per size *(see note below)	D4791	\$	120	each
Fractured Faces, per size *(see note below)	D5821, T335	\$	130	each
Lightweight Pieces ( <i>Per specific gravity of heavy liquid</i> )	C123, T113	\$	370	each
Los Angeles Abrasion, Large Aggregate	C535	\$	250	each
Los Angeles Abrasion, Small Aggregate	C131, T96	\$	250	each
Mortar Sand Strength	C87, CT515	\$	820	each
Organic Impurities	C40, T21	\$	125	each
Sand Equivalent	D2419, T176	\$	190	each
Sieve Analysis, % Finer than No. 200 Sieve	C117, T11	\$	115	each
Sieve Analysis, Fine	C136, T27	\$	165	each

Sieve Analysis, Coarse	C136, T27	\$	165	each
Sieve Analysis, Coarse and Fine	C136, T27	\$	210	each
Soundness of Aggregate, per size <i>*(see note below)</i>	C88, T104	\$	190	each
Unit Weight	C29, T19	\$	84	each
Water Content	D2216, C566, T255	\$	32	each
Texas Wet Ball Mill	TEX116E	\$	380	each
Decantation Wash	TEX406A	\$	115	each
Uncompacted Void Content of Fine Aggregate	C1252, T304	\$	180	each
<i>*Tests are billed by each size fraction tested. The quantity of fractions tested is dependent on the sample gradation and test method.</i>				

### FILTER MEDIA TESTS

Test	Standard Test Method†	Fee		
Filter Media, Sieve Analysis <i>(includes d10, d60, es, cu)</i>	AWWA B100	\$	230	each
Filter Media, Mohs Hardness	AWWA B100	\$	230	each
Acid Solubility	AWWA B100	\$	230	each

### CONCRETE TESTS

Test	Standard Test Method†	Fee		
Concrete Compression	C39	\$	42	each
Concrete Core Compression	C42	\$	105	each
Concrete Flexural Strength	C78	\$	130	each
Hydraulic Cement Mortar Compression	C109 (field cast)	\$	42	each
Concrete Drying Shrinkage, set of 3*	C157	\$	640	Each
Concrete Core Thickness	C174	\$	58	each
Concrete Laboratory Trial Batch**	C192	\$	1,750	each
Concrete Time of Set by Penetration Resistance	C403, C191	\$	2,400	each
Concrete Modulus of Elasticity	C469	\$	600	each
Concrete Splitting Tensile Strength	C496	\$	175	each
Concrete Absorption	C497, C642	\$	200	each
Concrete Cylinder Unit Weight	C567	\$	200	each
Non-Shrink Grout Compression	C1107, C579	\$	42	each
Shotcrete Compression	C1140, C1604	\$	89	each
Shotcrete Core Grading	ACI 506.3	\$	150	each
Concrete Paving Slab Modulus of Rupture	C1782	\$	945	each
Concrete Direct Tensile	D2936, CRD C164	\$	525	each
CLSM Compression	D4832	\$	58	each

*\*For sets greater than 3, add \$100 per prism*

*\*\*Includes up to 9 cylinders or 9 flex beams, additional cylinders, beams, or shrinkage prisms charged at individual unit rates*

### ROLLER COMPACTED CONCRETE TESTS

Test	Standard Test Method†	Fee		
RCC Compression	C1435/C39	\$	68	each
RCC Air Content	C1849	\$	125	each
RCC Unit Weight	C1849	\$	125	each
RCC Consistency and Density (VeBe)	C1170	\$	1,680	each
RCC Accelerated Cure	C1768 - modified	\$	790	each
RCC Trial Batch	ACI 211.1	\$	inquire	each

## MASONRY TESTS

Test	Standard Test Method†	Fee		
Masonry Grout Compression	C1019, C942	\$	42	each
Masonry Mortar Compression	C270, C780	\$	42	each
Masonry Core Compression and Shear	CA DSA	\$	210	each
Masonry Prism Compression	C1314	\$	160	each
CMU Absorption and Received Moisture	C140	\$	125	each
CMU Compression	C140	\$	130	each
CMU Dimension Verification	C140	\$	60	each
CMU Lineal Shrinkage	C426	\$	350	each

## ASPHALT TESTS

MIX PROPERTY TESTS				
Test	Standard Test Method†	Fee		
Air Voids Determination ( <i>calculation only</i> )	D3203, AI-MS-2	\$	68	each
VMA Determination ( <i>calculation only</i> )	AI-MS-2, CT-LP-2	\$	68	each
VFA Determination ( <i>calculation only</i> )	AI-MS-2, CT-LP-2	\$	68	each
Volumetric Properties ( <i>calculation only</i> )	AI-MS-2, CT-LP-2	\$	68	each
AC Moisture Content	T329	\$	85	each
Gradation of Extracted Aggregate	D5444	\$	160	each
AC Content by Extraction	D2172	\$	375	each
AC Content by Ignition Oven	D6307, T308	\$	200	each
AC Ignition Oven Calibration ( <i>determination of mix correction</i> )	D6307	\$	440	each
Hveem Stability	D1560	\$	440	each
Hveem Stability without Compaction	D1560	\$	230	each
Marshall Stability and Flow ( <i>does not include compaction</i> )	D6927	\$	220	each

DESIGN AND DENSITY TESTS				
Test	Standard Test Method†	Fee		
AC Core Thickness	D3549	\$	45	each
AC Core Unit Weight & Thickness	D1188, D2726, D3549	\$	68	each
Unit Weight, Gyrotory Method	D6925, T312	\$	400	each
Unit Weight, Hveem Method	D1561	\$	390	each
Unit Weight, Marshall Method	D6926	\$	285	each
Maximum Theoretical Specific Gravity	D2041	\$	210	each
Moisture Induced Damage	T283	\$	1,695	each
Hamburg Wheel Track, Set of 2	T324	\$	1,270	each
Index of Retained Strength	D1075	\$	1,445	each
Indirect Tensile Strength ( <i>does not include compaction</i> )	D6931	\$	1,050	set/3
Indirect Tensile Strength of Cored Specimen	D6931	\$	440	each
Caltrans Tensile Strength Ratio	CT371	\$	2,310	each
Caltrans Optimum Bitumen Content OGFC	CT368	\$	2,135	each
Film Stripping	CT302	\$	190	each
Mix Design, Hveem Method	CT367	\$	Inquire	each
Mix Design, Marshall Method	AI-MS-2	\$	Inquire	each
Mix Design, Superpave Method	AI-MS-2	\$	Inquire	each
EMULSION TESTS				
Test	Standard Test Method†	Fee		
Emulsion Settlement	D6930, T59	\$	295	each
Emulsion Sieve Test	D6933, T59	\$	130	each
Emulsion Storage Stability	D6930, T59	\$	230	each
Emulsion Torsional Recovery	CT332	\$	200	each

Particle Charge	D7402, T59	\$	130	each
Residue by Evaporation	D6934, T59	\$	145	each
Saybolt Viscosity	D7946, T59	\$	200	each
Slurry Seal Wet Track Abrasion	D3910, ISSA TB100	\$	440	each

### METAL TESTS

<b>BOLT TESTS</b>				
Test	Standard Test Method <sup>†</sup>	Fee		
Bolt Assembly Suite (Bolt, Nut, Washer) *	F606	\$	300	each
Bolt Hardness	E18	\$	40	each
Bolt Proof Load	F606	\$	60	each
Bolt Wedge Tensile	F606	\$	65	each
Nut Hardness	E18	\$	40	each
Nut Proof Load	F606	\$	60	each
Washer Hardness	E18	\$	40	each

*\*An 'assembly' is one bolt, one nut and one washer. The suite consists of a bolt wedge tensile test, bolt and nut proof load tests, and hardness tests on all three pieces.*

<b>REINFORCING BAR TESTS</b>				
Test	Standard Test Method <sup>†</sup>	Fee		
Bend	A370, E290	\$	60	each
Rebar Tensile, up to No. 11	A370, E8	\$	120	each
Rebar Tensile, No. 14 and No. 18	A370, E8	\$	300	each
Rebar Coupler Slip	A370, A1034, CT670	\$	225	each
Rebar Coupler Tensile, up to No. 11	A370, A1034, CT670	\$	150	each
Rebar Coupler Tensile, No. 14 and No. 18	A370, A1034, CT670	\$	350	each
Headed Rebar Tensile, up to No. 11	A370, A970	\$	150	each
Headed Rebar Tensile, No. 14 and No. 18	A370, A970	\$	350	each
Modulus of Elasticity*	A370	\$	300	Each
Epoxy Coating Thickness	A775, A934	\$	130	each
Epoxy Coating Continuity – Holiday Test	A775, A934	\$	130	each
Epoxy Flexibility - Bending	A775, A934	\$	130	each

*\*Machined specimens only, in addition to the tensile fee.*

<b>METAL TESTS</b>				
Test	Standard Test Method <sup>†</sup>	Fee		
PT Strand Tensile	A370, A1061	\$	255	each
Anchor Bolt Tensile, up to 1.5" dia.	F1554	\$	190	each
Anchor Bolt Tensile, greater than 1.5" dia.	F1554	\$	350	each
Reduced Section Tensile*	A370	\$	250	each
Rockwell Hardness	E18	\$	40	each
Macroetch	E381	\$	500	each
Charpy Impact, Set of 3 **	A370, A673	\$	1,000	each
Galvanization Thickness	B499, E376	\$	35	each
Fireproofing Density	E605	\$	115	each

*\*Machining test specimens is not included. Additional fees for stress-strain diagram.*

*\*\*Machining test specimens is not included. Additional fees will be assessed for testing at temperatures other than 40°F.*

**MISCELLANEOUS TESTS**

<b>Test</b>	<b>Standard Test Method†</b>	<b>Fee</b>		
Tensile and Elastic Modulus Polymer Composite Materials	D3039	\$	805	set/5

**SAMPLE PREPARATION**

<b>Test</b>	<b>Standard Test Method†</b>	<b>Fee</b>		
Sample Cutting and Trimming		\$	42	each
Sample Preparation		\$	75	each
Sample Remolding		\$	100	each
Contamination Fee		\$	varies	each
Sample Disposal Fee		\$	10	each

**EXHIBIT A TO AMENDMENT NO. 3  
PROFESSIONAL SERVICES AGREEMENT WITH KLEINFELDER, INC. DATED  
APRIL 8, 2021**

## CITY OF INDUSTRY

### PROFESSIONAL SERVICES AGREEMENT

This PROFESSIONAL SERVICES AGREEMENT (“Agreement”), is made and effective as of April 8, 2021 (“Effective Date”), between the City of Industry, a municipal corporation (“City”) and Kleinfelder, Inc., a California Corporation (“Consultant”). The City and Consultant are hereinafter collectively referred to as the “Parties”.

#### RECITALS

**WHEREAS**, City desires to engage Consultant to perform the services described herein, and Consultant desires to perform such services in accordance with the terms and conditions set forth herein.

**NOW, THEREFORE**, for and in consideration of the mutual covenants and conditions herein contained, City and Consultant agree as follows:

#### 1. TERM

This Agreement shall commence on the Effective Date, and shall remain and continue in effect until tasks described herein are completed, but in no event later than April 7, 2023, unless sooner terminated pursuant to the provisions of this Agreement.

#### 2. SERVICES

(a) Consultant shall perform the tasks (“Services”) described and set forth in Exhibit A, attached hereto and incorporated herein as though set forth in full. (“Scope of Services”). Tasks other than those specifically described in the Scope of Services shall not be performed without prior written approval of the City. The Services shall be performed by Consultant, unless prior written approval is first obtained from the City. In the event of conflict or inconsistency between the terms of this Agreement and Exhibit A, the terms of this Agreement shall prevail.

(b) City shall have the right to request, in writing, changes to the Services. Any such changes mutually agreed upon by the Parties, and any corresponding increase or decrease in compensation, shall be incorporated by written amendment to this Agreement.

(c) Consultant shall perform all Services in a manner reasonably satisfactory to the City and in a first-class manner in conformance with the standards of quality normally observed by an entity providing on-call geotechnical engineering services, serving a municipal agency.

(d) Consultant shall comply with all applicable federal, state, and local laws, regulations and ordinances in the performance of this Agreement, including but not limited to, the conflict of interest provisions of Government Code Section 1090 and the Political Reform Act (Government Code Section 81000 *et seq.*). During the term of this Agreement, Consultant shall not perform any work for another person or entity for whom Consultant

was not working on the Effective Date if both (i) such work would require Consultant to abstain from a decision under this Agreement pursuant to a conflict of interest statute or law; and (ii) City has not consented in writing to Consultant's performance of such work. No officer or employee of City shall have any financial interest in this Agreement that would violate California Government Code Sections 1090 *et seq.* Consultant hereby warrants that it is not now, nor has it been in the previous twelve (12) months, an employee, agent, appointee, or official of the City. If Consultant was an employee, agent, appointee, or official of the City in the previous twelve (12) months, Consultant warrants that it did not participate in any manner in the forming of this Agreement. Consultant understands that, if this Agreement is made in violation of Government Code §1090 *et. seq.*, the entire Agreement is void and Consultant will not be entitled to any compensation for Services performed pursuant to this Agreement, and Consultant will be required to reimburse the City for any sums paid to the Consultant. Consultant understands that, in addition to the foregoing, it may be subject to criminal prosecution for a violation of Government Code § 1090 and, if applicable, will be disqualified from holding public office in the State of California.

(e) Consultant represents that it has, or will secure at its own expense, all licensed personnel required to perform the Services. All Services shall be performed by Consultant or under its supervision, and all personnel engaged in the Services shall be qualified and licensed to perform such services.

### **3. MANAGEMENT**

City Manager shall represent the City in all matters pertaining to the administration of this Agreement, review and approval of all products submitted by Consultant, but shall have no authority to modify the Services or the compensation due to Consultant.

### **4. PAYMENT**

(a) The City agrees to pay Consultant monthly, in accordance with the payment rates and terms and the schedule of payment as set forth in Exhibit B ("Rate Schedule"), attached hereto and incorporated herein by this reference as though set forth in full, based upon actual time spent on the above tasks. This amount shall not exceed Five Hundred Thousand Dollars (\$500,000.00) for the total Term of the Agreement unless additional payment is approved as provided in this Agreement.

(b) Consultant shall not be compensated for any services rendered in connection with its performance of this Agreement which are in addition to those set forth herein, unless such additional services are authorized in advance and in writing by the City. Consultant shall be compensated for any additional services in the amounts and in the manner as agreed to by City and Consultant at the time City's written authorization is given to Consultant for the performance of said services.

(c) Consultant shall submit invoices monthly for actual services performed. Invoices shall be submitted on or about the first business day of each month, or as soon thereafter as practical, for services provided in the previous month. Payment shall be made within thirty (30)

days of receipt of each invoice as to all non-disputed fees. If the City disputes any of Consultant's fees it shall give written notice to Consultant within thirty (30) days of receipt of an invoice of any disputed fees set forth on the invoice. Any final payment under this Agreement shall be made within 45 days of receipt of an invoice therefore.

## **5. LABOR CODE AND PREVAILING WAGES**

(a) Consultant represents and warrants that it is aware of the requirements of California Labor Code Section 1720, *et seq.*, and 1770, *et seq.*, as well as California Code of Regulations, Title 8, Section 16000, *et seq.*, ("Prevailing Wage Laws"), which require the payment of prevailing wage rates and the performance of other requirements on "Public Works" and "Maintenance" projects. If the Services are being performed as part of an applicable "Public Works" or "Maintenance" project, as defined by the Prevailing Wage Laws, and if the total compensation is \$15,000.00 or more, Consultant agrees to fully comply with such Prevailing Wage Laws. City shall provide Consultant with a copy of the prevailing rates of per diem wages in effect at the commencement of this Agreement. Consultant shall make copies of the prevailing rates of per diem wages for each craft, classification or type of worker needed to execute the Services available to interested parties upon request, and shall post copies at the Consultant's principal place of business and any location where the Services are performed. Consultant shall indemnify, defend and hold harmless, the City, its elected officials, officers, employees and agents, from and against any liability (including liability for claims, suits, actions, arbitration proceedings, administrative proceedings, regulatory proceedings, losses, expenses or costs of any kind, whether actual, alleged or threatened, including legal counsel fees and costs, court costs, interest, defense costs, and expert witness fees), where the same arise out of, are a consequence of, or are in any way attributable to, in whole or in part, Consultant's or by any individual or agency for which Consultant is legally liable, including but not limited to officers, agents, employees or subcontractors of Consultant, failure or alleged failure to comply with Prevailing Wage Laws.

(b) In accordance with the requirements of Labor Code Section 1776, Consultant shall keep accurate payroll records which are either on forms provided by the Division of Labor Standards Enforcement or which contain the same information required by such forms. Consultant shall make all such records available for inspection at all reasonable hours.

(c) To the extent applicable, Consultant shall comply with the provisions of Section 1777.5 of the Labor Code with respect to the employment of properly registered apprentices upon public works.

(d) Consultant shall comply with the legal days' work and overtime requirements of Sections 1813 and 1815 of the Labor Code.

(e) If the Services are being performed as part of an applicable Public works or Maintenance project, then pursuant to Labor Code Sections 1725.5 and 1771.1, the Consultant and all subconsultants performing such Services must be registered with the Department of

Industrial Relations. Consultant shall maintain registration for the duration of the Agreement and require the same of any subconsultants, as applicable. This Services set forth in this Agreement may also be subject to compliance monitoring and enforcement by the Department of Industrial Relations. It shall be Consultant's sole responsibility to comply with all applicable registration and labor compliance requirements.

## **6. SUSPENSION OR TERMINATION OF AGREEMENT**

(a) The City may at any time, for any reason, with or without cause, suspend or terminate this Agreement, or any portion hereof, by serving upon the Consultant at least ten (10) days prior written notice. Upon receipt of said notice, the Consultant shall immediately cease all work under this Agreement, unless the notice provides otherwise. If the City suspends or terminates a portion of this Agreement such suspension or termination shall not make void or invalidate the remainder of this Agreement.

(b) In the event this Agreement is terminated pursuant to this Section, the City shall pay to Consultant the actual value of the work performed up to the time of termination, provided that the work performed is of value to the City. Upon termination of the Agreement pursuant to this Section, the Consultant shall submit an invoice to the City pursuant to Section 5 of this Agreement.

## **7. OWNERSHIP OF DOCUMENTS**

(a) Consultant shall maintain complete and accurate records with respect to sales, costs, expenses, receipts, and other such information required by City that relate to the performance of services under this Agreement. Consultant shall maintain adequate records of services provided in sufficient detail to permit an evaluation of services. All such records shall be maintained in accordance with generally accepted accounting principles and shall be clearly identified and readily accessible. Consultant shall provide free access to the representatives of City or its designees at reasonable times to review such books and records; shall give City the right to examine and audit said books and records; shall permit City to make transcripts or copies therefrom as necessary; and shall allow inspection of all work, data, documents, proceedings, and activities related to this Agreement. Such records, together with supporting documents, shall be maintained for a period of three (3) years after receipt of final payment.

(b) Upon completion of, or in the event of termination or suspension of this Agreement, all original documents, designs, drawings, maps, models, computer files, surveys, notes, and other documents prepared in the course of providing the services to be performed pursuant to this Agreement shall become the sole property of the City and may be used, reused, or otherwise disposed of by the City without the permission of the Consultant. With respect to computer files, Consultant shall make available to the City, at the Consultant's office, and upon reasonable written request by the City, the necessary computer software and hardware for purposes of accessing, compiling, transferring, copying and/or printing computer files. Consultant hereby grants to City all right, title, and interest, including any copyright, in and to the documents, designs, drawings, maps, models, computer files, surveys, notes, and other documents prepared by Consultant in the course of providing the services under this Agreement. All reports, documents, or other written material developed by Consultant in the

performance of the Services pursuant to this Agreement, shall be and remain the property of the City.

## **8. INDEMNIFICATION**

### (a) Indemnity for professional liability

When the law establishes a professional standard of care for Consultant's Services, to the fullest extent permitted by law, Consultant shall indemnify, protect, defend and hold harmless the City and any and all of its officials, employees and agents ("Indemnified Parties") from and against any and all losses, liabilities, damages, costs and expenses, including legal counsel's fees and costs caused in whole or in part by any negligent or wrongful act, error or omission of Consultant, its officers, agents, employees or Subconsultants (or any agency or individual that Consultant shall bear the legal liability thereof) in the performance of professional services under this Agreement.

### (b) Indemnity for other than professional liability

Other than in the performance of professional services and to the full extent permitted by law, Consultant shall indemnify, defend and hold harmless City, and any and all of its employees, officials and agents from and against any liability (including liability for claims, suits, actions, arbitration proceedings, administrative proceedings, regulatory proceedings, losses, expenses or costs of any kind, whether actual, alleged or threatened, including legal counsel fees and costs, court costs, interest, defense costs, and expert witness fees), where the same arise out of, are a consequence of, or are in any way attributable to, in whole or in part, the performance of this Agreement by Consultant or by any individual or agency for which Consultant is legally liable, including but not limited to officers, agents, employees or subcontractors of Consultant.

(c) DUTY TO DEFEND. In the event the City, its officers, employees, agents and/or volunteers are made a party to any action, claim, lawsuit, or other adversarial proceeding arising from the performance of the services encompassed by this Agreement, and upon demand by City, Consultant shall have an immediate duty to defend the City at Consultant's cost or at City's option, to reimburse the City for its costs of defense, including reasonable attorney's fees and costs incurred in the defense of such matters.

Payment by City is not a condition precedent to enforcement of this indemnity. In the event of any dispute between Consultant and City, as to whether liability arises from the sole negligence of the City or its officers, employees, or agents, Consultant will be obligated to pay for City's defense until such time as a final judgment has been entered adjudicating the City as solely negligent. Consultant will not be entitled in the absence of such a determination to any reimbursement of defense costs including but not limited to attorney's fees, expert fees and costs of litigation.

## **9. INSURANCE**

Consultant shall maintain prior to the beginning of and for the duration of this Agreement insurance coverage as specified in Exhibit C attached hereto and incorporated herein by reference.

## **10. INDEPENDENT CONSULTANT**

(a) Consultant is and shall at all times remain as to the City a wholly independent consultant and/or independent contractor. The personnel performing the services under this Agreement on behalf of Consultant shall at all times be under Consultants exclusive direction and control. Neither City nor any of its officers, employees, or agents shall have control over the conduct of Consultant or any of Consultant's officers, employees, or agents, except as set forth in this Agreement. Consultant shall not at any time or in any manner represent that it or any of its officers, employees, or agents are in any manner officers, employees, or agents of the City. Consultant shall not incur or have the power to incur any debt, obligation, or liability whatever against the City, or bind the City in any manner.

(b) No employee benefits shall be available to Consultant in connection with the performance of this Agreement. Except for the fees paid to Consultant as provided in the Agreement, City shall not pay salaries, wages, or other compensation to Consultant for performing services hereunder for City. City shall not be liable for compensation or indemnification to Consultant for injury or sickness arising out of performing services hereunder.

(c) Consultant shall indemnify, defend and hold harmless, the City, its elected officials, officers, employees and agents, from and against any liability (including liability for claims, suits, actions, arbitration proceedings, administrative proceedings, regulatory proceedings, losses, expenses or costs of any kind, whether actual, alleged or threatened, including contributions to any retirement and/or pension plan, legal counsel fees and costs, court costs, interest, defense costs, and expert witness fees), where the same arise out of, are a consequence of, or are in any way attributable to, in whole or in part, Consultant's or by any individual or agency for which Consultant is legally liable, including but not limited to officers, agents, employees or subconsultants of Consultant, service as an independent contractor. The indemnity provisions set forth in this Section 10(c) shall survive the termination of this Agreement, and are in addition to any other rights or remedies the City may have under the law.

## **11. LEGAL RESPONSIBILITIES**

The Consultant shall keep itself informed of State and Federal laws and regulations which in any manner affect those employed by it or in any way affect the performance of its service pursuant to this Agreement. The Consultant shall at all times observe and comply with all such laws and regulations. The City, and its officers and employees, shall not be liable at law or in equity occasioned by failure of the Consultant to comply with this Section.

**12. UNDUE INFLUENCE**

Consultant declares and warrants that no undue influence or pressure was used against or in concert with any officer or employee of the City in connection with the award, terms or implementation of this Agreement, including any method of coercion, confidential financial arrangement, or financial inducement. No officer or employee of the City has or will receive compensation, directly or indirectly, from Consultant, or from any officer, employee or agent of Consultant, in connection with the award of this Agreement or any work to be conducted as a result of this Agreement. Violation of this Section shall be a material breach of this Agreement entitling the City to any and all remedies at law or in equity.

**13. NO BENEFIT TO ARISE TO LOCAL OFFICERS AND EMPLOYEES**

No member, officer, or employee of City, or their designees or agents, and no public official who exercises authority over or responsibilities with respect to the Project during his/her tenure or for one year thereafter, shall have any interest, direct or indirect, in any agreement or sub-agreement, or the proceeds thereof, for work to be performed in connection with the Project performed under this Agreement.

**14. RELEASE OF INFORMATION/CONFLICTS OF INTEREST**

(a) All information gained by Consultant in performance of this Agreement shall be considered confidential and shall not be released by Consultant without City's prior written authorization. Consultant, its officers, employees, agents, or subconsultants, shall not without written authorization from the City, voluntarily provide declarations, letters of support, testimony at depositions, response to interrogatories, or other information concerning the work performed under this Agreement or relating to any project or property located within the City, unless otherwise required by law or court order.

(b) Consultant shall promptly notify City should Consultant, its officers, employees, agents, or subconsultants be served with any summons, complaint, subpoena, notice of deposition, request for documents, interrogatories, request for admissions, or other discovery request ("Discovery"), court order, or subpoena from any person or party regarding this Agreement and the work performed there under or with respect to any project or property located within the City, unless Consultant is prohibited by law from informing the City of such Discovery, court order or subpoena. City retains the right, but has no obligation, to represent Consultant and/or be present at any deposition, hearing, or similar proceeding as allowed by law. Unless City is a party to the lawsuit, arbitration, or administrative proceeding and is adverse to Consultant in such proceeding, Consultant agrees to cooperate fully with the City and to provide the opportunity to review any response to discovery requests provided by Consultant. However, City's right to review any such response does not imply or mean the right by City to control, direct, or rewrite said response.

**15. NOTICES**

Any notices which either party may desire to give to the other party under this Agreement must be in writing and may be given either by (i) personal service, (ii) delivery by a reputable document delivery service, such as but not limited to, Federal Express, which provides a receipt

showing date and time of delivery, or (iii) mailing in the United States Mail, certified mail, postage prepaid, return receipt requested, addressed to the address of the party as set forth below or at any other address as that party may later designate by notice:

To City: City of Industry  
15625 E. Stafford, Suite 100  
City of Industry, CA 91744  
Attention: City Manager

With a Copy To: Casso & Sparks, LLP  
13300 Crossroads Parkway North, Suite 410  
City of Industry, CA 91746  
Attention: James M. Casso, City Attorney

To Consultant: Kleinfelder, Inc.  
2280 Market Street, Suite 300  
Riverside, CA 92501  
Attention: Mark Peabody, Los Angeles Area  
Manager, Vice President

**16. ASSIGNMENT**

The Consultant shall not assign the performance of this Agreement, nor any part thereof, nor any monies due hereunder, without prior written consent of the City.

Before retaining or contracting with any subconsultant for any services under this Agreement, Consultant shall provide City with the identity of the proposed subconsultant, a copy of the proposed written contract between Consultant and such subconsultant which shall include an indemnity provision similar to the one provided herein and identifying City as an indemnified party, or an incorporation of the indemnity provision provided herein, and proof that such proposed subconsultant carries insurance at least equal to that required by this Agreement or obtain a written waiver from the City for such insurance.

Notwithstanding Consultant's use of any subconsultant, Consultant shall be responsible to the City for the performance of its subconsultant as it would be if Consultant had performed the Services itself. Nothing in this Agreement shall be deemed or construed to create a contractual relationship between the City and any subconsultant employed by Consultant. Consultant shall be solely responsible for payments to any subconsultants. Consultant shall indemnify, defend and hold harmless the Indemnified Parties for any claims arising from, or related to, the services performed by a subconsultant under this Agreement.

**17. GOVERNING LAW/ATTORNEYS' FEES**

The City and Consultant understand and agree that the laws of the State of California shall govern the rights, obligations, duties, and liabilities of the parties to this Agreement and also govern the interpretation of this Agreement. Any litigation concerning this Agreement shall take place in the municipal, superior, or federal district court in Los Angeles County, California.

If any action at law or suit in equity is brought to enforce or interpret the provisions of this Agreement, or arising out of or relating to the Services provided by Consultant under this Agreement, the prevailing party shall be entitled to reasonable attorneys' fees and all related costs, including costs of expert witnesses and consultants, as well as costs on appeal, in addition to any other relief to which it may be entitled.

**18. ENTIRE AGREEMENT**

This Agreement contains the entire understanding between the Parties relating to the obligations of the Parties described in this Agreement. All prior or contemporaneous agreements, understandings, representations, and statements, oral or written and pertaining to the subject of this Agreement or with respect to the terms and conditions of this Agreement, are merged into this Agreement and shall be of no further force or effect. Each party is entering into this Agreement based solely upon the representations set forth herein and upon each party's own independent investigation of any and all facts such party deems material.

**19. SEVERABILITY**

If any term or provision of this Agreement or the application thereof to any person or circumstance shall, to any extent, be invalid or unenforceable, then such term or provision shall be amended to, and solely to, the extent necessary to cure such invalidity or unenforceability, and in its amended form shall be enforceable. In such event, the remainder of this Agreement, or the application of such term or provision to persons or circumstances other than those as to which it is held invalid or unenforceable, shall not be affected thereby, and each term and provision of this Agreement shall be valid and be enforced to the fullest extent permitted by law.

**20. COUNTERPARTS**

This Agreement may be executed in multiple counterparts, each of which shall be deemed an original, but all of which taken together shall constitute one and the same instrument.

**21. CAPTIONS**

The captions appearing at the commencement of the sections hereof, and in any paragraph thereof, are descriptive only and shall have no significance in the interpretation of this Agreement.

**22. WAIVER**

The waiver by City or Consultant of any breach of any term, covenant or condition herein contained shall not be deemed to be a waiver of such term, covenant or condition or of any subsequent breach of the same or any other term, covenant or condition herein contained. No term, covenant or condition of this Agreement shall be deemed to have been waived by City or Consultant unless in writing.

**23. REMEDIES**

Each right, power and remedy provided for herein or now or hereafter existing at law, in equity, by statute, or otherwise shall be cumulative and shall be in addition to every other right, power, or remedy provided for herein or now or hereafter existing at law, in equity, by statute, or otherwise. The exercise, the commencement of the exercise, or the forbearance of the exercise by any party of any one or more of such rights, powers or remedies shall not preclude the simultaneous or later exercise by such party of any of all of such other rights, powers or remedies.

**24. AUTHORITY TO EXECUTE THIS AGREEMENT**

The person or persons executing this Agreement on behalf of Consultant represents and warrants that he/she has the authority to execute this Agreement on behalf of the Consultant and has the authority to bind Consultant to the performance of its obligations hereunder.

IN WITNESS WHEREOF, the Parties hereto have caused this Agreement to be executed as of the Effective Date.

**“CITY”**  
**City of Industry**

**“CONSULTANT”**  
Kleinfelder, Inc.

By:   
Troy Helling, City Manager

By:   
Mark Peabody, Los Angeles Area  
Manager, Vice President

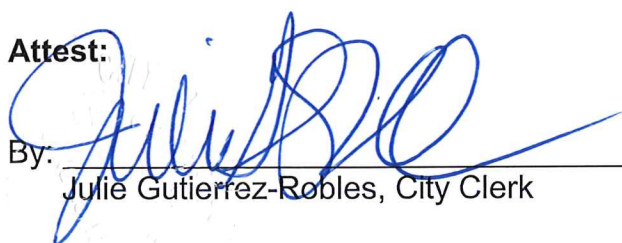
**Attest:**  
  
By: Julie Gutierrez-Robles, City Clerk

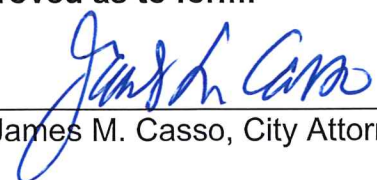
**Approved as to form:**  
  
By: James M. Casso, City Attorney

- Attachments:      Exhibit A      Scope of Services  
                         Exhibit B      Rate Schedule  
                         Exhibit C      Insurance Requirements

## EXHIBIT A

### SCOPE OF SERVICES

Consultant shall provide the following geotechnical engineering services, as requested by the City:

- Site Investigation
- Dam/Reservoir Design
- Earthquake Engineering
- Levee Design
- Seepage Analysis
- Excavation Stability
- Seismicity
- Geology
- Dam/Reservoir Safety
- Earth Slopes & Embankments
- Surface Water Issues
- Fault Studies
- Geophysics
- Engineering Geology
- Foundation Engineering
- Retaining & Buried Structures
- Groundwater Issues
- Hydrogeology
- Soil/Ground Improvement
- Pavement Engineering
- Infiltration Evaluation
- Geotechnical Observation and Testing
- Construction Materials Observation and Testing

EXHIBIT B  
RATE SCHEDULE

<u>Classification:</u>	<u>Rate:</u>
Professional (Geologist).....	\$125/ hour
Staff Professional .....	\$150/ hour
Project Professional .....	\$170/ hour
Senior Professional .....	\$185/ hour
Principal Professional .....	\$225/ hour
Project Manager .....	\$185/ hour
Senior Project Manager.....	\$225/ hour
Designer/Drafter .....	\$115/ hour
Senior Designer/Drafter.....	\$125/ hour
Project Controls Professional .....	\$115/ hour

**TECHNICAL STAFF RATES**

Technician - Prevailing Wage .....	\$124*/ hour
Technician – Non-Prevailing Wage .....	\$94/ hour

**ADMINISTRATIVE STAFF RATES**

Administrator .....	\$85/ hour
Project Administrator .....	\$120/ hour

\*Denotes Prevailing Wage Technician Rate per the California DIR. We will increase our technician rate accordingly based on increases in the DIR rate.

## EXHIBIT C

### INSURANCE REQUIREMENTS

Without limiting Consultant's indemnification of City, and prior to commencement of the Services, Consultant shall obtain, provide and maintain at its own expense during the term of this Agreement, policies of insurance of the type and amounts described below and in a form satisfactory to City.

**General liability insurance.** Consultant shall maintain commercial general liability insurance with coverage at least as broad as Insurance Services Office form CG 00 01, in an amount not less than \$1,000,000.00 per occurrence, \$2,000,000.00 general aggregate, for bodily injury, personal injury, and property damage. The policy must include contractual liability that has not been amended. Any endorsement restricting standard ISO "insured contract" language will not be accepted.

**Automobile liability insurance.** Consultant shall maintain automobile insurance at least as broad as Insurance Services Office form CA 00 01 covering bodily injury and property damage for all activities of the Consultant arising out of or in connection with Work to be performed under this Agreement, including coverage for any owned, hired, non-owned or rented vehicles, in an amount not less than \$1,000,000.00 combined single limit for each accident.

**Professional liability (errors & omissions) insurance.** Consultant shall maintain professional liability insurance that covers the Services to be performed in connection with this Agreement, in the minimum amount of \$1,000,000 per claim and in the aggregate. Any policy inception date, continuity date, or retroactive date must be before the effective date of this agreement and Consultant agrees to maintain continuous coverage through a period no less than three years after completion of the services required by this agreement.

**Workers' compensation insurance.** Consultant shall maintain Workers' Compensation Insurance (Statutory Limits) and Employer's Liability Insurance (with limits of at least \$1,000,000.00).

Consultant shall submit to City, along with the certificate of insurance, a Waiver of Subrogation endorsement in favor of City, its officers, agents, employees and volunteers.

**Proof of insurance.** Consultant shall provide certificates of insurance to City as evidence of the insurance coverage required herein, along with a waiver of subrogation endorsement for workers' compensation. Insurance certificates and endorsement must be approved by City's Risk Manager prior to commencement of performance. Current certification of insurance shall be kept on file with City at all times during the term of this contract. City reserves the right to require complete, certified copies of all required insurance policies, at any time.

**Duration of coverage.** Consultant shall procure and maintain for the duration of the contract insurance against claims for injuries to persons or damages to property, which may arise from or in connection with the performance of the Services hereunder by Consultant, his agents, representatives, employees or subconsultants.

**Primary/noncontributing.** Coverage provided by Consultant shall be primary and any insurance or self-insurance procured or maintained by City shall not be required to contribute with it. The limits of insurance required herein may be satisfied by a combination of primary and umbrella or excess insurance. Any umbrella or excess insurance shall contain or be endorsed to contain a provision that such coverage shall also apply on a primary and non-contributory basis for the benefit of City before the City's own insurance or self-insurance shall be called upon to protect it as a named insured.

**City's rights of enforcement.** In the event any policy of insurance required under this Agreement does not comply with these specifications or is canceled and not replaced, City has the right but not the duty to obtain the insurance it deems necessary and any premium paid by City will be promptly reimbursed by Consultant, or City will withhold amounts sufficient to pay premium from Consultant payments. In the alternative, City may cancel this Agreement.

**Acceptable insurers.** All insurance policies shall be issued by an insurance company currently authorized by the Insurance Commissioner to transact business of insurance in the State of California, with an assigned policyholders' Rating of A- (or higher) and Financial Size Category Class VI (or larger) in accordance with the latest edition of Best's Key Rating Guide, unless otherwise approved by the City's Risk Manager.

**Waiver of subrogation.** All insurance coverage maintained or procured pursuant to this agreement shall be endorsed to waive subrogation against City, its elected or appointed officers, agents, officials, employees and volunteers or shall specifically allow Consultant or others providing insurance evidence in compliance with these specifications to waive their right of recovery prior to a loss. Consultant hereby waives its own right of recovery against City, and shall require similar written express waivers and insurance clauses from each of its subconsultants.

**Enforcement of contract provisions (non estoppel).** Consultant acknowledges and agrees that any actual or alleged failure on the part of the City to inform Consultant of non-compliance with any requirement imposes no additional obligations on the City nor does it waive any rights hereunder.

**Requirements not limiting.** Requirements of specific coverage features or limits contained in this Section are not intended as a limitation on coverage, limits or other requirements, or a waiver of any coverage normally provided by any insurance. Specific reference to a given coverage feature is for purposes of clarification only as it pertains to a given issue and is not intended by any party or insured to be all inclusive, or to the exclusion of other coverage, or a waiver of any type. If the Consultant maintains higher limits than the minimums shown above, the City requires and shall be entitled to coverage for the higher limits maintained by the Consultant. Any available insurance proceeds in excess of the specified minimum limits of insurance and coverage shall be available to the City.

Notice of cancellation. Consultant agrees to oblige its insurance agent or broker and insurers to provide to City with a thirty (30) day notice of cancellation (except for nonpayment for which a ten (10) day notice is required) or nonrenewal of coverage for each required coverage.

**Additional insured status.** General liability policies shall provide or be endorsed to provide that City and its officers, officials, employees, and agents, and volunteers shall be additional insureds under such policies. This provision shall also apply to any excess liability policies.

**Prohibition of undisclosed coverage limitations.** None of the coverages required herein will be in compliance with these requirements if they include any limiting endorsement of any kind that has not been first submitted to City and approved of in writing.

**Separation of Insureds.** A severability of interests provision must apply for all additional insureds ensuring that Consultant's insurance shall apply separately to each insured against whom claim is made or suit is brought, except with respect to the insurer's limits of liability. The policy(ies) shall not contain any cross-liability exclusions.

**Pass Through Clause.** Consultant agrees to ensure that its subconsultants, subcontractors, and any other party involved with the project who is brought onto or involved in the project by Consultant, provide the same minimum insurance coverage and endorsements required of Consultant. Consultant agrees to monitor and review all such coverage and assumes all responsibility for ensuring that such coverage is provided in conformity with the requirements of this section. Consultant agrees that upon request, all agreements with consultants, subcontractors, and others engaged in the project will be submitted to City for review.

**City's right to revise specifications.** The City reserves the right at any time during the term of the contract to change the amounts and types of insurance required by giving the Consultant ninety (90) days advance written notice of such change. If such change results in substantial additional cost to the Consultant, the City and Consultant may renegotiate Consultant's compensation.

**Self-insured retentions.** Any self-insured retentions must be declared to and approved by the City. The City reserves the right to require that self-insured retentions be eliminated, lowered, or replaced by a deductible. Self-insurance will not be considered to comply with these specifications unless approved by the City.

**Timely notice of claims.** Consultant shall give the City prompt and timely notice of claims made or suits instituted that arise out of or result from Consultant's performance under this Agreement, and that involve or may involve coverage under any of the required liability policies.

**Additional insurance.** Consultant shall also procure and maintain, at its own cost and expense, any additional kinds of insurance, which in its own judgment may be necessary for its proper protection and prosecution of the work.

ITEM NO. 6.10



# CITY OF INDUSTRY

## MEMORANDUM

**TO:** Honorable Mayor and Members of the City Council

**FROM:** Joshua Nelson, City Manager

**STAFF:** Bing Hyun, Asst. City Manager

**DATE:** April 24, 2025

**SUBJECT:** Consideration of a Public Health Services Contract with the County of Los Angeles for public health services

---

### **Background:**

The County of Los Angeles Department of Public Health (“County”) has provided public health services to Industry since the City’s incorporation in 1957. The current Public Health Services Contract was last amended in 1959. Public health services provided by the County include:

1. Appointment of the County’s Health Officer to act as the City’s Health Officer.
2. Enforcement of various public health regulations including the County Health Code, which is adopted by reference pursuant to Industry Municipal Code 8.04.010 and 8.04.020; statutes related to public health; and orders, quarantines, and other regulations prescribed by the California Department of Public Health.
3. Issuance of required public health permits.

### **Discussion:**

The County’s Board of Supervisors approved a revised Agreement on October 22, 2024, and now requires cities that wish to continue receiving County public health services to enter into the revised Agreement.

The proposed Public Health Services Contract (“Agreement”) continues to authorize the County to provide existing services and enforce public health laws within the City. The new Agreement will remain in effect through June 30, 2029, and will automatically renew for consecutive five-year terms unless either party provides written notice of termination at least 180 days before July 1 of any given year.

### **Fiscal Impact:**

There is no fiscal impact. Public health permit fees are established, collected and retained by

the County. This would continue under this Agreement.

**Recommendation:**

Staff recommends that the City Council approve the Agreement.

**Exhibits:**

1. City of Industry PH-005623

**DEPARTMENT OF PUBLIC HEALTH  
PUBLIC HEALTH SERVICES CONTRACT**

THIS CONTRACT "Contract" is made and entered into on \_\_\_\_\_

by and between

COUNTY OF LOS ANGELES  
(hereafter "County")

and

CITY OF INDUSTRY  
(hereafter "City")

THIS PUBLIC HEALTH SERVICES CONTRACT ("Contract") is made by and between the County of Los Angeles, hereinafter referred to as the "County", and the City of Industry hereinafter referred to as "City."

**RECITALS:**

The City desires to continue to contract with the County for the performance of public health services by the County's Department of Public Health ("Public Health"), for the County's Health Officer to act as the City's Health Officer, and for the County's Department of Public Health to serve as the City's Environmental Health Department.

The County agrees to continue performing such services on the terms and conditions set forth in this Contract.

This Contract is authorized by California Health and Safety Code Sections 101400 and 101405.

To effectuate public health services for the City, the County and its duly appointed Health Officer shall exercise the powers and duties that are conferred upon local health officers by law.

The County Health Officer shall fulfill the obligations and exercise the authority conferred by California Health and Safety Code Sections 101470 and 101475 within the territorial jurisdiction of the City in the performance of this Contract.

**THEREFORE, THE PARTIES MUTUALLY AGREE AS FOLLOWS:**

1. **TERM:** This Contract shall become effective upon date of execution, and replace all prior contracts for public health services between the City and County. This contract shall continue in full force and effect until June 30, 2029. Subject to Section 7 below, this Contract shall thereafter be automatically renewed for consecutive five (5) year terms, for an indefinite period, without further action by either City or County, unless City or County terminates the Contract in the manner set forth in Section 7.
  
2. **PUBLIC HEALTH SERVICES:** The County and the County's Health Officer shall observe and enforce within the territorial jurisdiction of the City all of the following:
  - a. Orders, quarantine, and other regulations, concerning public health, prescribed by the California Department of Public Health ("CDPH").
  - b. Statutes relating to public health.
  - c. Provisions of Los Angeles County Code, Title 11, and any amendments thereto, as adopted by City by ordinance or resolution, to the same extent as they are enforced in the unincorporated area of the County.
  
3. **DESCRIPTION OF PUBLIC HEALTH FUNCTIONS:**
  - a. The performance of all public health services, the standard of performance and other matters incidental to the performance of public health services and observation and enforcement of public health statutes, regulations, ordinances and CDPH orders and guidance shall be determined solely at the discretion of the County Health Officer and/or Director of County

Public Health. The control of County personnel under this Contract shall remain exclusively with the County.

- b. The County agrees to continue to perform for the City such public health services as are authorized or mandated by state laws or regulations related to public health, to be performed by the local health officer or local enforcement agency.
  - i. Pursuant to California Health and Safety Code section 101045, the County shall investigate health and sanitary conditions in detention facilities operated by the City, if any. County may bill and receive payment from City for inspection and reporting services in the manner provided by Paragraph 4, subsections (g) and (h) of this Contract.
  - ii. For future enactments of state law or regulation, County agrees to perform public health services that impose a specific duty or obligation on the local health officer to observe or enforce. Should future state law statutory or regulatory enactment related to public health not impose a duty or obligation on the local health officer, City may request in writing that the County perform that public health service. Should County elect to perform that discretionary public health service for City, pursuant to such City request, then County may bill and receive payment from City for inspection and reporting services in the manner provided by Section 4, subsections (g) and (h) of this Contract.
- c. The County agrees to continue to perform for the City such public health services as authorized or mandated by provisions of Title 11 of the Los Angeles County Code, and any amendments or additions thereto, that the City has adopted via ordinance or resolution.
  - i. Should the County Board of Supervisors enact future provisions to or amend existing provisions of Title 11 of the Los Angeles County Code, County will inform the City of the newly enacted provision or amendment via email to the City's Manager, and describe the

- enacted new provision or amendment and the impact to the services performed under this Contract, if any.
- ii. For future ordinances that may be enacted by the Board of Supervisors into Title 11 of the Los Angeles County Code, in order for the County to observe and enforce that enacted ordinance within the City, the City must approve the incorporation of the identical version of that new Title 11 provision into its municipal code via ordinance or by resolution of the City Council.
  - iii. Any future amendments to provisions of Title 11 of the Los Angeles County Code that exist in the City's Municipal Code at the date of the execution of this Contract, shall be incorporated by the City into its municipal code.
- d. The County shall issue public health permits and licenses to permittees located within the City and collect the fees as provided for in Los Angeles County Code, Title 8, Chapter 8.04. Such fees shall be retained by County Public Health for the benefit of County as full compensation for the services performed by the Public Health Director and County Health Officer on behalf of the City.
- i. County may, from time to time, amend or alter the public health permit or license fees charged to those individuals or entities required to obtain a public health permit or license pursuant to either state statute or Los Angeles County Code, Title 8, Chapter 8.04.
  - ii. City may not set, collect, or retain public health permit or license fees for any public health service performed by County under this Contract.
- e. For the purpose of performing said functions, County shall furnish and supply all necessary labor, supervision, equipment, and supplies necessary to provide the public health services described in this Contract and as necessary to protect the public health, safety, and welfare as determined by Public Health in its sole discretion. All persons employed in

the performance of public health services and functions under this Contract shall be County personnel.

**4. GENERAL TERMS:**

- a. To facilitate the performance of public health services, City and County will cooperate and assist each other to fulfill the purpose and intent of this Contract.
- b. Exhibit A of this Contract, which is attached hereto and incorporated herein, shall provide the language of the City's Municipal Code, as amended, that reflects the City's specific adoption of Division 1 of Title 11 of the Los Angeles County Code as of the effective date of this Contract. Exhibit A may be revised to reflect any changes to the City's Municipal Code regarding Title 11 of the Los Angeles County Code.
- c. All persons employed in the performance of such public health duties, functions and services for City shall be County employees or personnel and no City employee shall be supplanted by County, and no person employed by County under this Contract shall have any City pension, civil service, or any status or right.
- d. The City shall not be called upon to assume any liability for the direct payment of any salary, wages or other compensation to any County personnel performing services hereunder for the City, or be liable for compensation to or required to indemnify any County employee for injury or sickness arising out of his or her employment.
- e. The parties have executed an Assumption of Liability Contract approved by the Board of Supervisors on December 27, 1977, and/or a Joint Indemnity Contract approved by the Board of Supervisors on October 8, 1991. Whichever of these documents the City has signed later in time is currently in effect and hereby made a part of and incorporated into this Contract by reference. In the event that the Board of Supervisors later approves a revised Joint Indemnity Contract, and the City executes the

revised contract, the subsequent contract as of its effective date shall supersede the contract previously in effect between the parties hereto.

- f. City is not required to separately reimburse County for the performance or enforcement of any City ordinance or resolution which adopts identical provisions of Los Angeles County Code, Title 11, and its amendments.
  - g. Should City request in writing additional public health services of the County, that are not required by statute, regulation or CDPH Order, or as provided in Title 11 of the Los Angeles County Code, the County may charge the City, at rates approved by the Board of Supervisors, an hourly rate that will reimburse the County for the costs for the provision of those specific public health services.
  - h. County, through its Director of Public Health, must render to City within twenty (20) calendar days after the close of each calendar month an itemized invoice which covers all extra services performed for City if such services were requested by the City in writing, during said month, and City must pay County within thirty (30) days after date of such invoice.
  - i. If a violation of public health statutes, regulations or ordinances results in a public health hazard within the City, County will notify the City Manager in writing. If the City elects to pursue legal prosecution or abatement, City shall provide to County contact information for counsel that will represent the City or the People in any legal proceeding to abate or mitigate the public health hazard. City shall bear the full cost of such proceedings. County may bill City on an hourly basis for time spent by County employees participating in such legal proceedings.
5. **NOTICES:** Notices hereunder must be in writing and may either be delivered personally or sent by registered or certified mail, return receipt requested, postage prepaid, attention to the parties at the addresses listed below. Public Health Director, or the Director's designee, is authorized to execute all notices or demands which are required or permitted by County under this Contract.

Addresses and parties to be notified may be changed by providing at least ten (10) working days prior written notice to the other party.

A. Notices to County must be addressed as follows:

- (1) Department of Public Health  
Environmental Health – Administrative Headquarters  
5050 Commerce Drive  
Baldwin Park, California 91706  
Attention: Director, Environmental Health  
E-mail: [EHAdmin@ph.lacounty.gov](mailto:EHAdmin@ph.lacounty.gov)
- (2) Department of Public Health  
Contracts and Grants Division  
5555 Ferguson Drive, 2<sup>nd</sup> Floor, Suite 210  
Commerce, CA 90022  
Attention: Division Director  
Email: [contracts-grants@ph.lacounty.gov](mailto:contracts-grants@ph.lacounty.gov)
- (3) Department of Public Health  
Office of the Director  
Attention: Director, Public Health  
313 North Figueroa Street  
Los Angeles, CA 90012  
Email: [DPHDirector@ph.lacounty.gov](mailto:DPHDirector@ph.lacounty.gov)

B. Notices to City must be addressed as follows:

- (1) City of: Industry  
Attention: City Manager  
15625 Mayor Dave Way  
Industry, CA 91744  
Email: [jnelson@cityofindustry.org](mailto:jnelson@cityofindustry.org)  
Phone: (626) 333-2211

6. **GOVERNING LAW, JURISDICTION, AND VENUE:** This Contract will be governed by, and will be construed in accordance with, the laws of the State of California. City agrees and consents to the exclusive jurisdiction of the courts of the State of California or the United States Courthouse, Central District, Western Division, for all purposes regarding this Contract and further agrees and consents

that venue of any action brought under this Contract shall be exclusively in the County of Los Angeles.

7. **TERMINATION FOR CONVENIENCE:** The performance of services under this Contract may be terminated, with or without cause, in whole or in part, from time to time when such action is deemed by County or City to be in their own best interest. Termination of services hereunder shall be effectuated by the delivery of an advance written Notice of Termination of the entire Contract by one party to the other at least one hundred and eighty (180) calendar days prior to July 1 of the following calendar year. The termination of services may only be effective on July 1 of the calendar year, so as to assure no lapse in public health and local health officer services to the residents of City.
  
8. **ALTERATION OF TERMS/AMENDMENTS:** The body of this Contract and any Exhibits attached hereto, and documents incorporated by reference, fully expresses all understandings of the parties concerning all matters covered and shall constitute the total Contract. No addition to, or alteration of, the terms of this Contract, whether by written or verbal understanding of the parties, their officers, employees or agents, shall be valid and effective unless made in the form of a written amendment to this Contract which is formally approved and executed by the parties in the same manner as this Contract.
  
9. **INDEPENDENT CONTRACTOR STATUS:** This Contract is by and between the County and City and is not intended, and shall not be construed, to create the relationship of agent, servant, employee, partnership, joint venture, or association, as between the County and City. The employees and agents of one party shall not be, or be construed to be, the employees or agents of the other party for any purpose whatsoever.



IN WITNESS WHEREOF, the Board of Supervisors of the County of Los Angeles has caused this Contract to be subscribed by its Director of Public Health, and Contractor has caused this Contract to be subscribed in its behalf by its duly authorized officer, the month, day, and year first written above.

**CITY OF INDUSTRY**

**COUNTY OF LOS ANGELES**

By: \_\_\_\_\_  
Cory Moss  
Mayor

By: \_\_\_\_\_  
Barbara Ferrer, Ph.D., M.P.H., M.Ed.  
Director

Date: \_\_\_\_\_

Date: \_\_\_\_\_

APPROVED AS TO FORM  
BY THE OFFICE OF THE CITY ATTORNEY

APPROVED AS TO FORM  
BY THE OFFICE OF THE COUNTY COUNSEL

JAMES M. CASSO, City Attorney

DAWYN R. HARRISON, County Counsel

By: \_\_\_\_\_  
City Attorney

APPROVED AS TO CONTRACT  
ADMINISTRATION:  
Department of Public Health

Date: \_\_\_\_\_

By: \_\_\_\_\_  
Contracts and Grants Division

ATTEST:  
JULIE GUTIERREZ-ROBLES, City Clerk

Date: \_\_\_\_\_

By: \_\_\_\_\_  
City Clerk

Date: \_\_\_\_\_  
(AFFIX CORPORATE SEAL HERE)

#07642:db

**Exhibit A:**  
**CITIES - HEALTH OFFICER - ADOPTION OF COUNTY CODE**  
**INDUSTRY**

**ADOPTION OF OUR COUNTY CODE TITLE 8 & TITLE 11**

**8.04.010 Adoption of Health and Safety Code.**

A. The county of Los Angeles Health and Safety Code, codified as Division 1 of Title 11 of the Los Angeles County Code, as such code may be amended from time to time, except as hereinafter amended by this chapter, is adopted by reference as the Public Health and Safety Code of the city.

B. At least three copies of the current version of Division 1 of Title 11 of the Los Angeles County code will be at all times maintained in the office of the city clerk for use and examination by the public. (Ord. 709 § 2 B, 2005; Ord. 292 § 1, 1968; Ord. 272 § 1, 1967)

**8.04.020 Adoption of Public Health Licenses Code.**

A. The Los Angeles County Public Health Licenses Code, codified as Division 1 of Title 8 of the Los Angeles county code, as such code may be amended from time to time, except as hereinafter amended by this chapter, is adopted by reference as the Public Health Licenses Code of the city.

B. At least three copies of the current version of Division 1 of Title 8 of the Los Angeles County Code will be at all times maintained in the office of the city clerk for use and examination by the public. (Ord. 79 § 2 B, 2005; Ord. 372 § 2, 1974)

**CITY MUNICIPAL CODE EXCLUSION OF SPECIFIC PUBLIC HEALTH SERVICES**

None

ITEM NO. 7.1

**ORDINANCE NO. 835**

**AN ORDINANCE OF THE CITY COUNCIL OF THE CITY OF  
INDUSTRY, CALIFORNIA, REPEALING ORDINANCE NO. 823 AND  
APPROVING AN ADJUSTMENT TO THE MONTHLY  
COMPENSATION FOR THE MEMBERS OF THE CITY COUNCIL**

**WHEREAS**, Section 302 of the City’s Charter provides, in pertinent part, that compensation for Council Members may be increased by an Ordinance adopted in compliance with the provisions of California Government Code Section 36516.2; and

**WHEREAS**, Government Code Section 36516.2 was repealed in 1984, and its language is now included in Government Code Section 36516(a)(4). Pursuant to Section 36516(a)(4), the amount of the salary increase for a Council Member cannot exceed five percent for each calendar year from the operative date of the last salary adjustment; and

**WHEREAS**, on April 13, 2023, the City Council adopted Ordinance No. 823 setting the monthly compensation of Council Members at Two Thousand Six Hundred Eleven and 31/100 Dollars; and

**WHEREAS**, City Staff is recommending, pursuant to Government Code Section 36516(a)(4), a five (5%) increase per year since the last operative increase in July 2023. Pursuant to Staff’s recommendation, effective on July 1, 2025, the City Council’s monthly compensation shall be Two Thousand Eight Hundred Seventy-Two and 42/100 Dollars.

**NOW, THEREFORE, THE CITY COUNCIL OF THE CITY OF INDUSTRY,  
CALIFORNIA, DOES HEREBY ORDAIN AS FOLLOWS:**

**Section 1.** The above recitals are true and correct and are incorporated herein by reference.

**Section 2.** Ordinance No. 823 is hereby repealed as of the effective date of this Ordinance.

**Section 3.** Pursuant to Section 302 of the City’s Charter, and California Government Code Section 36516(a)(4), the monthly compensation for the City Council Members effective as of July 1, 2025, shall be the sum of Two Thousand Eight Hundred Seventy-Two and 42/100 Dollars.

**Section 4. Severability.** Should any section, subsection, clause, or provision of this Ordinance for any reason be held to be invalid or unconstitutional, such invalidity or unconstitutionality shall not affect the validity or constitutionality of the remaining portions of this Ordinance; it being hereby expressly declared that this Ordinance, and each section, subsection, sentence, clause, and phrase hereof would have been prepared, proposed, approved, and ratified irrespective of the fact that any one or more sections, subsections, sentences, clauses, or phrases be declared invalid, unenforceable, or unconstitutional.

**Section 5. Effective Date.** In accordance with California Government Code Section 36937, this Ordinance shall take effect and be in force thirty (30) days from passage and adoption.

**Section 6. Publication.** The City Clerk shall certify to the passage and adoption of this Ordinance and shall cause this Ordinance to be published and posted as required by law.

**PASSED, APPROVED AND ADOPTED** by the City Council of the City of Industry at a regular meeting held on May 8, 2025, by the following vote:

AYES: COUNCIL MEMBERS:

NOES: COUNCIL MEMBERS:

ABSTAIN: COUNCIL MEMBERS:

ABSENT: COUNCIL MEMBERS:

---

Cory C. Moss, Mayor

ATTEST:

---

Julie Gutierrez-Robles, City Clerk

ITEM NO. 7.2

Verbal Presentation